

## LBD Automatic Load Step Controller

**Minimizes Engine Wet-Stacking**

**Lowers Engine Output Emissions**

**Reduces Maintenance Costs**

**Less Downtime**

LBD's optional Load Level Control provides automatic load regulation by sensing the downstream connected load and adjusting the amount of supplemental load (load bank steps) applied. These user controls allow for a predetermined minimum load on the power source and helps to avoid the issues associated with lightly loaded conditions. Engine performance is optimized allowing for improved emissions control, while helping to stabilize voltage and frequency transients.



**Allows the Load Bank to be applied as a supplemental load**

**Prevents low load issues such as Wet-Stacking**

**Optimizes engine performance - emissions control**

**For use on LS Stationary Outdoor & LD Duct Mounted Load Banks**

**Used in Prime Power and Standby Applications**



### Engine Wet-Stacking

- Unburned fuel causes carbon build up
- Excessive oil consumption
- Reduced horsepower & efficiency
- Reduced power output (KW)
- Increased engine emissions
- Premature engine failure

## Operation

The Load Bank is installed in parallel with the facility load. A current transformer monitors the connected load and supplies feedback to the LBD Automatic Load Level Controller.

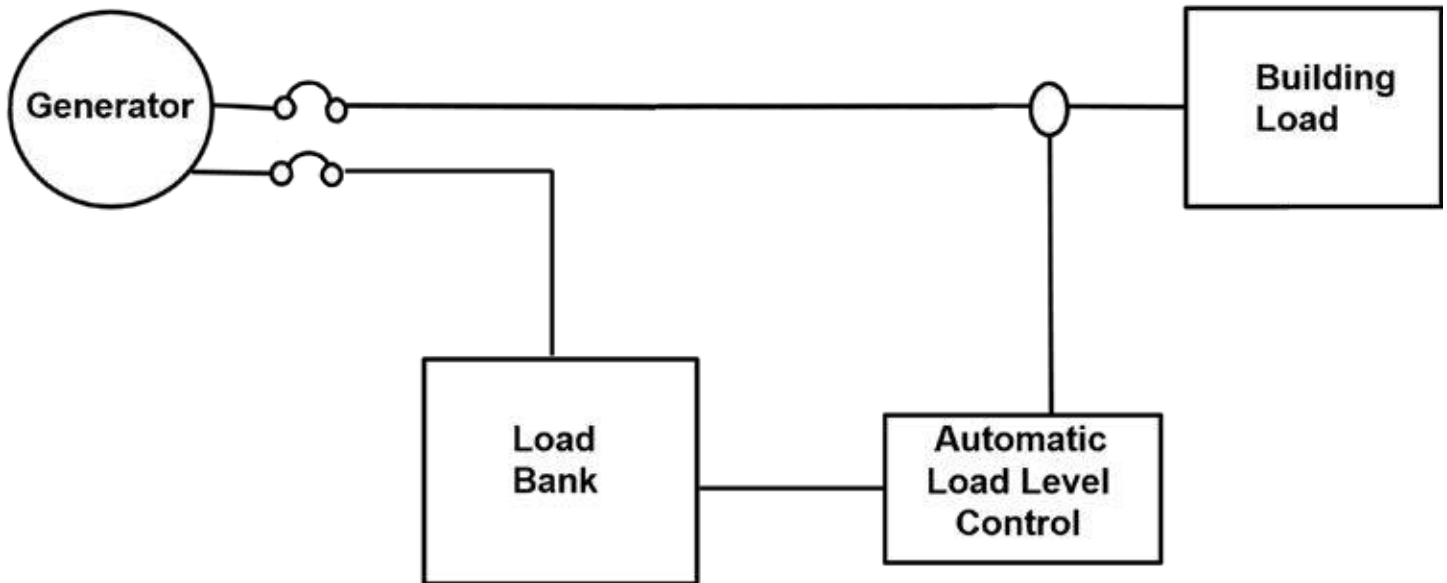

The Automatic Load Level Controller adds and subtracts Load Bank load in response to dynamic power fluctuations in the connected facility load. It utilizes the Load Bank as a “supplemental load” for maintaining a minimum load on the power source.

When the Controller is placed in the “Auto” position, an externally supplied “Transfer of Control” contact closure initiates the Load Bank controls and begins sensing downstream connected building load through the separately supplied current transformer providing the necessary feedback signal. After an initial time delay, the controller begins adding/ removing load steps accordingly as to keep a 40-60% load on the power source.

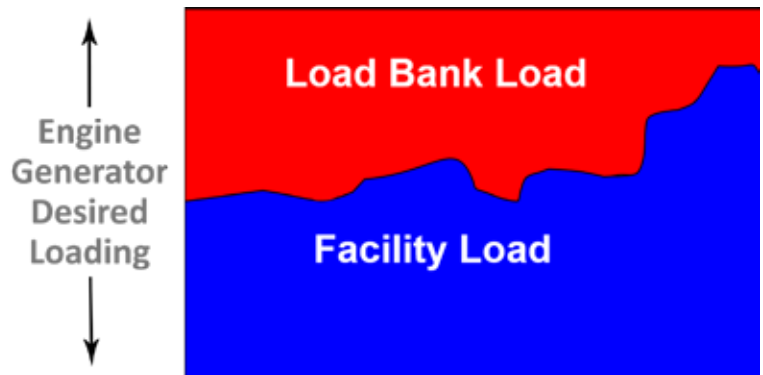

The Controller will continue to add & subtract load in response to the power fluctuations of the connected building load. By maintaining a minimum load on the power source, the various low load issues like Wet-Stacking are eliminated.

