

30kVA Transformer

Portable Power Distribution



APPLICATION RANGE

Trystar Step Down Transformer
30KVA 480V:208Y/120V

STANDARD FEATURES

- NEMA 3R all aluminum construction
- Mounted in heavy-duty cage w/castors, forklift pockets, lifting eyes, and storage basket
- Custom powder coat
- Custom UV-printed graphics
- Made in USA

CONFIGURATION

- Primary Side
 - Cordgrip Input w/10ft of 6/4 Type W Cable
 - 1 x 60A 480V Pin & Sleeve Receptacles
 - 1 x 60A 480V 3P Circuit Breakers
 - 50A 3P Primary Side Transformer Circuit Breaker
- Output
 - 100A 3P Secondary Side Transformer Circuit Breaker
 - 4 x 50A 125/250V Cali Style Receptacles
 - 4 x 50A 240V 2P GFCI Circuit Breakers
 - 10 x 20A 120V Duplex Receptacles
 - 10 x 20A 240V 1P GFCI Circuit Breakers

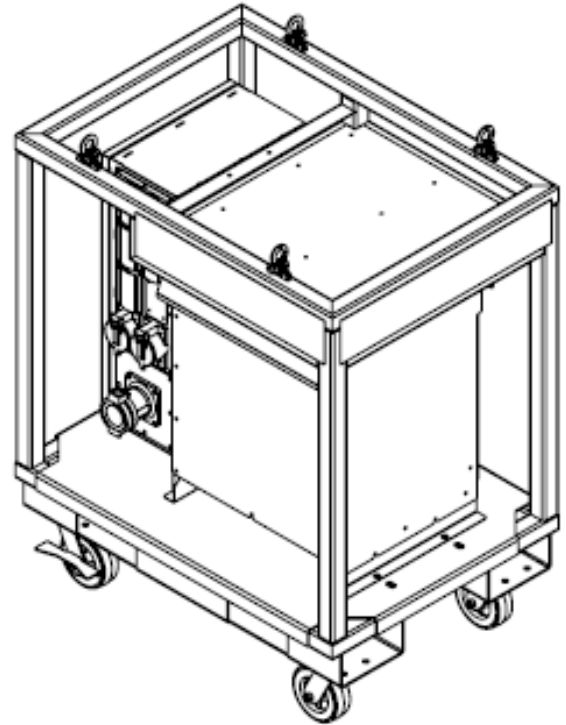

LISTINGS

- UL1640 Listed
- C(ETL) Listed
- UL 50 Listed
- NEMA 3R

*Images are representative, specific final design details may vary

30kVA Transformer

DIMENSIONS AND WEIGHTS



APPROXIMATE WEIGHT: 775 LBS.

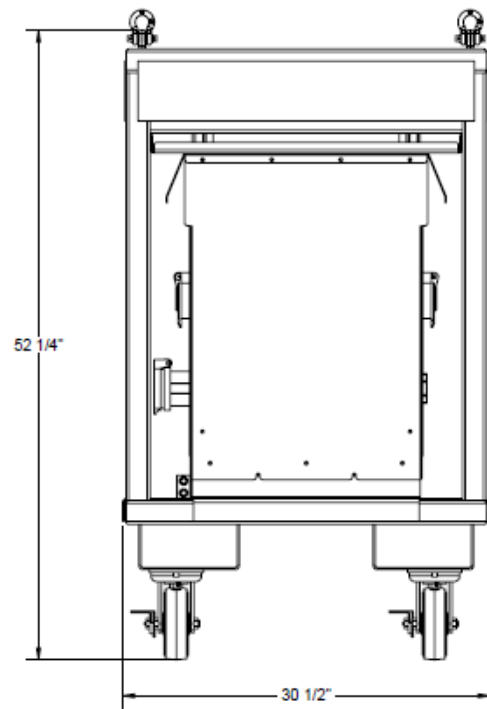
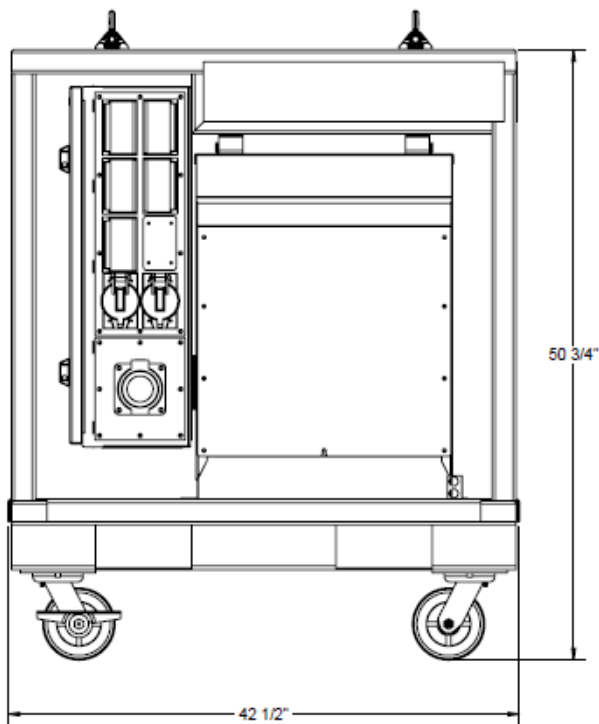

*Dimensions are representative, specific final design details may vary