

**Wall-mount, Wall-mount w/Leg Kit,  
and Flange-mount Models**



The Trystar GEN 3 Enclosure Installation Manual is organized into several easy-to-read sections. These include:

- Table of Contents
- General Safety Instructions/Information
- Installation Tools and Materials
- Unpacking Inspection and Precautions
- General Installation Instructions - GEN 3 Wall-mount, Flange-mount and Leg-kit.
- GEN 3 Series Line Drawings & Dimensions: GEN 3 Wall-mount, Padmount and Leg-kit.
- GEN 3 Series Installation Procedures
- Phase Monitor Installation and Maintenance
- Technical/Customer Service Support

This manual covers any applications using the Trystar GEN 3 Enclosures. These installation instructions set out the limiting factors for satisfactory performance of the enclosures. The information contained herein outlines and describes the requirements for proper installation of the enclosures.

## SAFETY PRECAUTIONS



### HAZARD OF ELECTRIC SHOCK, EXPLOSION, OR ARC FLASH

- Only qualified workers should install this equipment. Such work should be performed only after reading this entire set of instructions.
- NEVER work alone.
- Before performing visual inspections, tests, or maintenance on this equipment, disconnect all sources of electric power. Assume that all circuits are live until they have been completely de-energized, tested, and tagged. Pay particular attention to the design of the power system. Consider all sources of power, including the possibility of backfeeding.
- Apply appropriate personal protective equipment (PPE) and follow safe electrical practices. For example, in the USA, see NFPA 70E.
- Turn off all power supplying the equipment in which the device is to be installed before installing and wiring the device.
- Always use a properly rated voltage sensing device to confirm that power is off.
- Beware of potential hazards, wear personal protective equipment, and carefully inspect the work area for tools and objects that may have been left inside the equipment.
- The successful operation of this equipment depends upon proper handling, installation, and operation. Neglecting fundamental installation requirements may lead to personal injury as well as damage to electrical equipment or other property.

**Failure to follow these instructions can result in death or serious injury.**

#### NOTE:

*Electrical equipment should be serviced by qualified personnel. No responsibility is assumed by Trystar, LLC. for any consequences arising out of the use of this material. This document is not intended as an instruction manual for untrained persons.*

**TABLE OF CONTENTS**



**1—SAFETY ----- VI**  
 Overview -----vi  
 General Safety -----vi  
 Regulatory Compliance Standards ----- 1  
 Installation Tools ----- 1  
 Installation Materials----- 2

**2—UNPACKING ----- 3**  
 Shipping Package / Pallet Integrity ----- 3

**3—INSTALLATION CONSIDERATIONS ----- 4**  
 Torque Values for Machine Bolts ----- 4  
 Installation Site Considerations ----- 4  
 Cabinet Clearance ----- 4  
 Spacing / Temperatures----- 5

**4—LINE DRAWINGS / DIMENSIONS ----- 6**  
 Wall-mount Enclosures ----- 6  
 Cabinet Mounting and Spacing ----- 6  
 Wall-mount Enclosures w/Leg Kit----- 7  
 Flange-mount Enclosures ----- 8  
 Wall-mount Enclosures ----- 9  
 Wall-mount Enclosures w/Leg Kit-----10  
 Flange-mount Enclosures -----12

**5—INSTALLATION PROCEDURES ----- 14**  
 Large Enclosures -----14  
 Medium Enclosures -----15  
 Small Enclosures-----16  
 Large Enclosures w/Leg Kit -----17  
 Medium Enclosures w/Leg-Kit -----18  
 Small Enclosures w/Leg-Kit-----19  
 Large Flange-mount Enclosures -----20  
 Medium Flange-mount Enclosures -----21  
 Small Flange-mount Enclosures -----22  
 Bolts, Anchors, Hardware and Substrates-----23  
 Wall-mount Enclosures -----23  
 Unistrut® Hardware System -----23  
 Wall-mount w/Leg Kit Enclosures-----24  
 Flange-mount Enclosures -----25  
 Unistrut® Hardware System -----25  
 Flange-mount Enclosures -----25  
 Mounting Hole Locations and Dimensions Wall-mount - Large Cabinet-----26  
 Mounting Hole Locations and Dimensions Wall-mount - Medium Cabinet -----27  
 Mounting Hole Locations and Dimensions Wall-mount - Small Cabinet-----28  
 Mounting Hole Locations and Dimensions Wall-mount w/Leg

Continued next page...

Kit - Large Cabinet-----29  
 Mounting Hole Locations and Dimensions - Medium Cabinet -  
 30  
 Mounting Hole Locations and Dimensions - Small Cabinet -31  
 Mounting Hole Locations and Dimensions - Large Flange-  
 mount Cabinet-----32  
 Mounting Hole Locations and Dimensions - Large Flange-  
 mount Cabinet-----33  
 Mounting Hole Locations and Dimensions - Small Flange-  
 mount Cabinet-----34

**6—MOUNTING AND INSTALLATION - WALL-  
MOUNT CABINETS -----35**

Installation Location -----35  
 Mounting Configurations-----35  
 Masonry Wall Installation -----35  
 Metal Wall Installation -----36  
 Drill/Cut Holes in Substrate -----36  
 Punch/Drill Holes in Cabinets -----36  
 Mark Hole Locations -----36  
 Installing to Masonry Substrates-----37  
 Installing to Metal Wall  
 (Steel or Aluminum)-----37

**7—MOUNTING AND INSTALLATION - WALL-  
MOUNT CABINETS W/LEG KIT -----38**

Installation Location -----38  
 Mounting Configurations-----39  
 Concrete Pad/Island Installation-----39  
 Concrete Pad/Masonry Wall Installation-----39  
 Concrete Pad/Metal Wall Installation-----39  
 Drill/Cut Holes in Substrate -----40  
 Assemble Upper Cabinet-----41  
 Calculating Screw/Bolt Lengths -----41  
 Fastening Upper Cabinet -----42  
 Sealing Leg Kit to Concrete Pad-----43  
 Metal Wall Installation -----44  
 Installation Location -----45  
 Mounting Configurations-----45  
 Masonry Wall Installation -----46  
 Metal Wall Installation -----46

**8—FINALIZING INSTALLATION PROCEDURE  
- ALL CABINETS-----49**

Disconnect Main Power-----49  
 Route Conduits -----49  
 Pull Line Wires -----50  
 Connect Lines to Terminals -----50  
 Confirm Torque Values-----50  
 Phase Monitor Installation -----51

9—ANNUAL MAINTENANCE ----- 52  
10—TECHNICAL SUPPORT ----- 53  
11—PHASE ROTATION MONITOR TEST PRO-  
CEEDURE REPORT ----- 54  
12—NOTES ----- 55



**WARNING:** Electricity can be hazardous and can result in death or serious injury, Only qualified electricians and trained personnel should install, test or operate a Trystar GEN 3 Series Enclosure and related components. Before energizing the unit, wear appropriate personal protective equipment (PPE) to avoid potential injury or death.



**WARNING:** Moisture can cause electrical shocks, short circuits, and fires that can cause serious injuries or death. if for any reason you suspect the unit has been exposed to moisture during transit or storage, it should be dried out before being energized.



**NOTICE:** Any modifications to this unit after it leaves the factory will void any existing UL 1008 listing.

# 1—SAFETY

## Overview

Please read the Trystar GEN 3 Enclosure Installation Manual thoroughly before installing and working with an enclosure solution. It contains important safety information. Installer and operator safety, as well as optimum performance, depend on proper installation. The GEN 3 Series installation and operation must comply with all applicable local, state, and accepted codes and standards. Compliance with these standards, regulations and authorities is required to protect people and property. Following is a summary of key compliance related regulatory items applicable to installing one of the specified enclosures.

For installer protection and the safety of the product user, please comply with all Danger, Warning, and Caution statements within this document.

## General Safety

Safety is critical since installing an enclosure involves high-voltage electrical work and mechanical assembly. Treat the enclosure as high-energy electrical equipment and follow all applicable safety standards (e.g., NFPA 70E for electrical workplace safety). Ensure that any worker connecting or operating the generator wears appropriate PPE and uses proper tools. Also, follow the Occupational Safety and Health Administration (OSHA) and/or the guidelines of your company or authority having jurisdiction regarding the application and use of safety equipment and other matters related to installing a GEN 3 Series Enclosure on various substrates.

The Trystar GEN 3 Enclosure should be accessible only to qualified personnel. Keep the enclosure locked (padlocked) to prevent tampering or untrained individuals from connecting a generator. The NEC defines a “qualified person” as one with the skills and training to recognize electrical hazards.

### Some specific PPE items can include:

- Electrical gloves (Rated for 1000V+) for high-voltage work
- Arc-flash suit (Category-rated PPE) if working near live generator or enclosure terminals
- Insulated hand tools – Screwdrivers, pliers, and wrenches rated for electrical work
- Face shield and safety glasses for arc-flash protection and dust and debris
- Steel-toe boots for installing GEN 3 Series Enclosures (enclosures can weigh up to 480 lbs.)
- Hearing protection if working near operating generators
- Respiratory protection for metal or masonry dust or debris

**Regulatory Compliance Standards**

Installing an enclosure involves compliance with multiple agencies and local requirements. Obtain all required permits first. The critical areas of compliance include OSHA safety regulations, NEC Electrical Codes, NFPA fire protection standards, some EPA environmental rules, and local permitting requirements. Trystar always recommends adhering to these standards and authorities to protect people and property. Following is a summary of key compliance-related regulatory items pertaining to installing an enclosure.

| <b>Regulation</b>             | <b>Area of Compliance</b>                               |
|-------------------------------|---|
| OSHA (29 CFR 1910 and 1926)   | Workplace safety, electrical hazards, PPE, LOTO         |
| NEC (NFPA 70)                 | Electrical safety, wiring, grounding, transfer switches |
| NFPA 110 and 70E              | Generator, safety, emergency power requirements         |
| EPA (40 CFR)                  | Air quality, fuel storage, hazardous waste              |
| Local Codes and Permits       | Building permits, fire code, structural approvals       |
| Utility Interconnection       | Compliance with grid regulations and ATS safety         |
| Authority Having Jurisdiction | All related local codes and standard practices          |

**Table 1-1 – Key Compliance-related Regulatory Items**

**Installation Tools**

Installing a Trystar GEN 3 Enclosure requires electrical, mechanical and structural tools to ensure a safe and compliant installation. Notwithstanding anything herein to the contrary, if there is a conflict between any of the applicable standards, regulations, codes or laws incorporated by reference herein, the more restrictive and protective provision shall control. Following are some tools to consider:

1. Mechanical and Fastening Tools
  - Impact wrench
  - Complete socket set
  - Torque wrench
  - Box-end and adjustable wrenches
2. Drilling/Anchoring Tools and Bits
  - Rotary hammer
  - High-speed drill
  - Variable-speed drill
  - Diamond-tipped core bits
  - Carbide-tipped core bits
  - Cobalt drill bits
  - Titanium-coated drill bits
  - Step drill bit (Unibit®) or Carbide-tipped hole saw

- Hole saw with arbor set or knockout punch
- Compressed air source

### 3. Wire and Conduit Tools

- Heavy-duty cable cutters
- Hydraulic or manual crimper
- Conduit bender

### 4. Metering and Testing Tools

- Multimeter (CAT IV-rated)
- Clamp meter
- Phase rotation tester

### 5. Miscellaneous Tools

- Label maker (Industrial-Grade) for properly marking wiring and connections
- Job site vacuum to clean metal shavings from panel enclosures or dust and debris from masonry surfaces and holes
- Fish tape and pulling rope to run wires through conduit efficiently
- Portable work light for working in low-visibility areas

## Installation Materials

### NOTE:

*It is essential to use mounting and assembly hardware that is suitable for the installation. This may include hardware and fasteners resistant to caustic or chemical environments as well as high humidity, weather and salt air. Hardware selection can also be dictated by installations subject to high tension or shear forces. Depending on the application, the hardware may be made of stainless steel, galvanized steel, or zinc-coated steel. Tensile and shear strength should also be reviewed for all fasteners. Much of this information is contained on the packaging of the hardware or in the manufacturers' specification sheets. Exterior installations will require special fittings for EMT, RMC, and PVC to prevent the intrusion of water into the GEN 3 Enclosure, building, and any electrical connections.*

All materials and components must be installed in accordance with relevant listings and codes, including NEC (NFPA 70) for installation, NFPA 110 for the performance of emergency power systems, and NFPA 70E for safety. Per NEC compliance, ensure every component is UL-listed or third-party certified for its purpose.

### Conduit and Raceway Systems (Listed for Environment)

Trystar recommends using Rigid Metal Conduit (RMC), Metallic Tubing (EMT) and Schedule 80 rigid PVC with corresponding/ approved fittings for installation conditions and requirements

### Grounding and Bonding Components

Follow relevant codes and standards as well as any authority having jurisdiction

### Unistrut® Hardware Systems

Unistrut (strut channel) is a common installation system. Its use is covered in more detail in (Section 6: Mounting)

### Masonry Expansion Anchors and Hex Bolts

Masonry anchors including wedge and sleeve anchors are commonly used to fasten enclosures to substantial concrete, concrete block, and brick. Hex bolts are used for installation to metal walls. Their use is covered in more detail in (Section 6: Mounting)

*Follow NEC Chapter 9 tables for conduit fill limits and NEC Table 310.15(B)(3)(a) for derating parallel conductors. Also, follow NEC 408.3 for the arrangement of wires in panel enclosures, which should be neat and supported and not under strain.*

## 2—UNPACKING

### Shipping Package / Pallet Integrity



Figure 2-1 – Wrapped Pallet



Figure 2-2 – Unwrapped Pallet

**NOTE:**

*Moisture can cause electrical shocks, short circuits and fires that can serious injuries or death. If for any reason you suspect the unit has been exposed to moisture during transit or storage, it should be dried out before being installed and energized.*

Cabinets should be carefully inspected upon receipt to ensure that no damage occurred during shipment. Any damage should be reported at once and a claim should be placed against the transportation company. If any problems are found or parts are missing, please contact Trystar at: 1-507-333-3990. Make sure to have your order number ready.

Be careful using any sharp object when cutting the packaging as damage may occur to the cabinet. Perform a visual inspection to ensure the door and all hasps are in functional condition and that the panel integrity is intact.

**Nameplate and Connections:** Assuming there is no damage in transit, it is still necessary to inspect the product prior to installation. Check the nameplate against the order and job specifications to ensure installation of the correct enclosure. The enclosure should be connected only as described on its nameplate to match available line voltage and amperage.

All internal connections are torqued prior to shipment to ensure proper contact. However, it is possible some bolts and connections may have loosened in transit. All bolted electrical connections should be checked and tightened using the torque specifications shown on pg. 5.

***Installers should review and follow all NEC 110.26 subparts and conditions which cover access to and egress from a working space that must exist around all electrical equipment.***

In the context of an enclosure, installers should also follow NFPA 110, which treats the requirement for emergency power supply system (EPSS) equipment to be installed in locations that permit ready



Figure 2-3 – Product Labels

### 3—INSTALLATION CONSIDERATIONS

#### Torque Values for Machine Bolts

| GEN 3 Enclosure Torque Values for Machine Bolts<br>(Unless Otherwise Noted) |                       |
|---|-----------------------|
| Screw/Bolt/Lug Size   | Torque Value (+/- 5%) |
| 1/4   | 5.17 ft-lbs           |
| 5/16  | 10.67 ft-lbs          |
| 3/8   | 19 ft-lbs             |
| 7/16  | 30 ft-lbs             |
| 1/2   | 46 ft-lbs             |
| 5/8   | 92 ft-lbs             |
| 2S-350 Lug  | 31 ft-lbs             |
| 2S-600 Lug  | 42 ft-lbs             |

**NOTE:**

The Trystar GEN 3 Series Enclosures must be specified with an integral manual or automatic transfer switch from Trystar or otherwise be installed with another make and model of transfer switch.

**Table 3-1 – Torque Values**

#### Installation Site Considerations

accessibility for inspection, maintenance and repair.

- NFPA 110 (7.2.1) is the primary standard for EPSS location requirements
- NEC 110.26 applies to working space and access clearances for electrical equipment

In general, prepare the installation site according to local codes and applicable standards noted in *Section 1*.

Allow several inches of clearance around the cabinet’s front and sides to allow air circulation

- Install the cabinet (and generator if permanently installed) away from doors, windows and ventilation systems that can cause potential carbon monoxide hazards

#### Cabinet Clearance

- Ensure area will be accessible to allow for easy connection of an appropriately sized backup generator

Plan the site to avoid environmental hazards. NFPA 110 recommends protecting emergency power equipment from flooding, wind and debris hazards

#### Environmental/Access Planning Considerations

- Avoid installing the enclosure in low spots prone to water accumulation; if in a flood zone, elevate the enclosure above the base flood elevation or provide flood barriers
- Anchor the enclosure robustly to meet ratings
- Overall, choose an installation location and enclosure rating that

**NOTE:**

The Trystar GEN 3 Series Enclosure is designed for exterior operation only if configured as a docking station.

account for rain, snow, temperature extremes, UV sunlight and corrosion per NEC and manufacturer guidelines, to ensure long-term reliable operation

- Enclosure should not be obstructed by landscaping, fences, or parked vehicles; it should be accessible quickly in an emergency
- Recommend provisions for a gate or doorway wide enough to bring in equipment and personnel if the enclosure is located in a secure yard
- Recommend keeping the area around the enclosure clear of snow, ice, or debris. Snow removal plans should include clearing this emergency hookup point during winter
- Allow for adequate lighting and signage to lead an operator to the enclosure location since it may be used during a power outage at night
- Anticipate the possibility of the facility needing to upgrade to a larger portable or permanent generator or paralleled generators in the future in terms of available space
- Consider access in light of intrusion by unauthorized personnel or vandals when locating the GEN 3 Series Enclosure despite provided lock protection

**Spacing and Ambient Temperature**

- The enclosure and cables should not be exposed to excessive ambient heat or cold. If installed in an area with direct sun exposure, consider providing a sunshade
- Ensure that nearby equipment or structures do not radiate significant heat onto the enclosure. Maintain the NEC working space for personnel and as a buffer for airflow around the equipment

*The GEN 3 Enclosure operating specifications range from 32 °F (0 °C) to 104 °F (40 °C) with a humidity range of 5 to 95%*

**Working/Operator Interface Height**

- The mounting height of connectors and breakers should be within comfortable reach. Follow applicable codes or authority having jurisdiction

**Maintainability**

- Design the enclosure setup with maintenance in mind
- Choose an installation location where routine testing can be performed

**Spacing / Temperatures**



**Image 3-1 – Flange-mount Enclosure**

## 4—LINE DRAWINGS / DIMENSIONS

### Wall-mount Enclosures

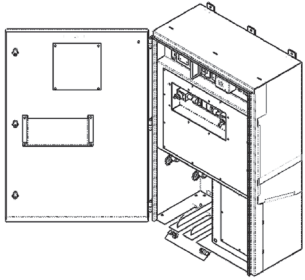

Small: 30" x 48" x 18.625"

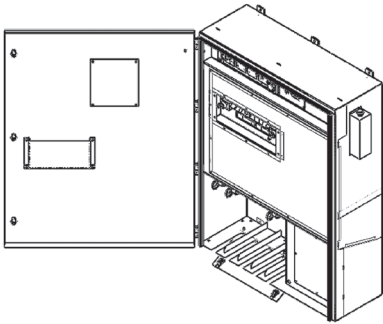

Medium: 40" x 54" x 18.625"

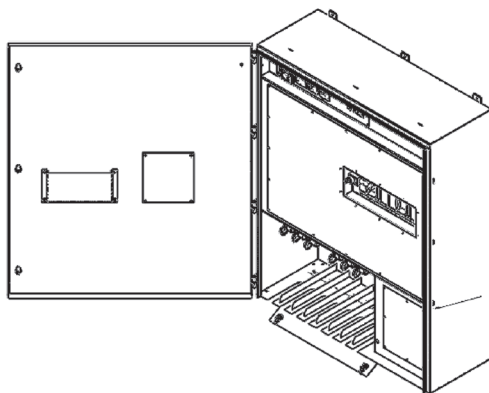

Large: 48" x 60" x 21.625"

Image 3-2 – Wall-mount Cabinet Sizes

### Cabinet Mounting and Spacing

The Trystar GEN 3 Series Enclosure is available in three different mounting options:

- Wall-mount
- Wall-mount with Leg Kit
- Flange-mount

The Wall-mount options are available in three standard sizes (W/H/D):

- Small: 30" x 48" x 18.625" (160 lbs.)
- Medium: 40" x 54" x 18.625" (320 lbs.)
- Large: 48" x 60" x 21.625" (480 lbs.)

The enclosure doors require varying free space to swing freely. Please follow all NEC 110.26 subparts and conditions.

The Trystar GEN 3 Series is designed for installation on substantial brick, block, concrete, steel or aluminum surfaces. The surface to which the enclosure is secured must be capable of supporting the weight of the cabinet (up to 480 lbs.) plus any cables attached to it. Appropriate wall anchors must be installed in aggregate-based surface.

In all installations, Trystar recommends robust hardware and bolts with suitable coatings and tensile and shear strengths as required by the installation. Follow the hardware manufacturer's specifications and installation instructions. Make sure cabinets are mounted using all anchor points.

#### NOTE:

*When used as a docking station, the Trystar GEN 3 Series Enclosure is designed for exterior installation only. All apertures connecting the cabinet interior to the building interior should be sealed to avoid the intrusion of carbon monoxide (CO) from an adjacent generator. Inhaling exhaust can cause serious medical conditions, including death.*

## Wall-mount Enclosures w/Leg Kit

The Wall-mount w/Leg Kit options are available in three standard sizes (W/H/D):

- Small: 30" x 78" x 18.625" (~ 160 lbs.)
- Medium: 40" x 84" x 18.625" (~ 320 lbs.)
- Large: 48" x 84" x 21.625" (~ 480 lbs.)

The enclosure doors require varying free space to swing freely. Please follow all NEC 110.26 subparts and conditions.

The Trystar GEN 3 Series is designed for installation on substantial brick, block, concrete, steel or aluminum surfaces. The surface to which the enclosure is secured must be capable of supporting the weight of the cabinet (up to 480 lbs.) plus any cables attached to it. Appropriate wall anchors must be installed in aggregate-based surface.

In all installations, Trystar recommends robust hardware and bolts with suitable coatings and tensile and shear strengths as required by the installation. Follow the hardware manufacturer's specifications and installation instructions. Make sure cabinets are mounted using all anchor points.

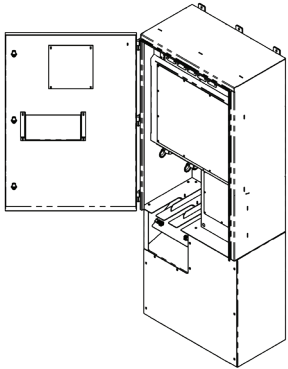

Small: 30" x 78" x 18.625"

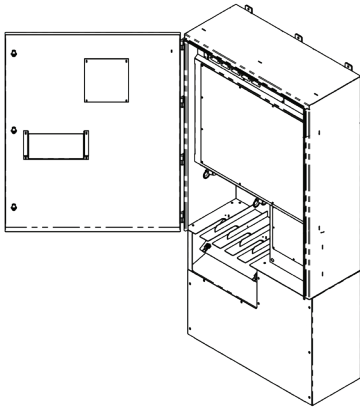

Medium: 40" x 84" x 18.625"

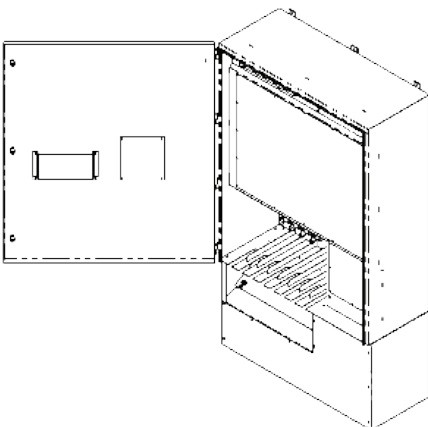

Large: 48" x 84" x 21.625"

### NOTE:

*When used as a docking station, the Trystar GEN 3 Series Enclosure is designed for exterior installation only. All apertures connecting the cabinet interior to the building interior should be sealed to avoid the intrusion of carbon monoxide (CO) from an adjacent generator. Inhaling exhaust can cause serious medical conditions, including death.*

Image 3-3 – Wall-mount w/Leg Kit Cabinet Sizes

**Flange-mount Enclosures**

The Flange-mount options are available in three standard sizes (W/H/D):

- Small: 34" x 64" x 18.375" (~ 160 lbs.)
- Medium: 44" x 70" x 18.375" (~ 320 lbs.)
- Large: 52" x 78" x 21.375" (~ 480 lbs.)

The enclosure doors require varying free space to swing freely. Please follow all NEC 110.26 subparts and conditions.

The Trystar GEN 3 Series is designed for installation on substantial brick, block, concrete, steel or aluminum surfaces. The surface to which the enclosure is secured must be capable of supporting the weight of the cabinet (up to 480 lbs.) plus any cables attached to it. Appropriate wall anchors must be installed in aggregate-based surface.

In all installations, Trystar recommends robust hardware and bolts with suitable coatings and tensile and shear strengths as required by the installation. Follow the hardware manufacturer's specifications and installation instructions. Make sure cabinets are mounted using all anchor points.

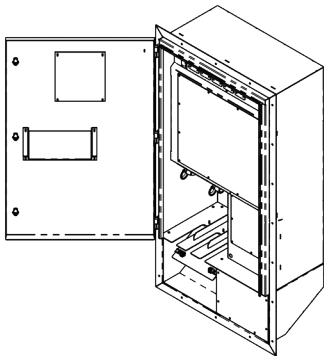

Small: 34" x 64" x 18.375"

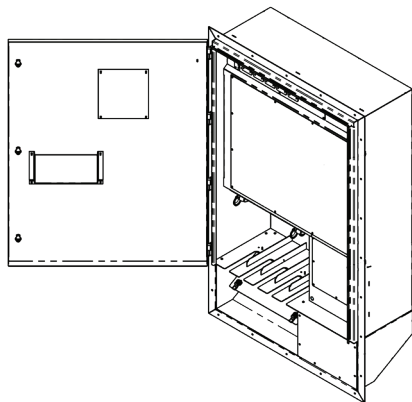

Medium: 44" x 70" x 18.375"

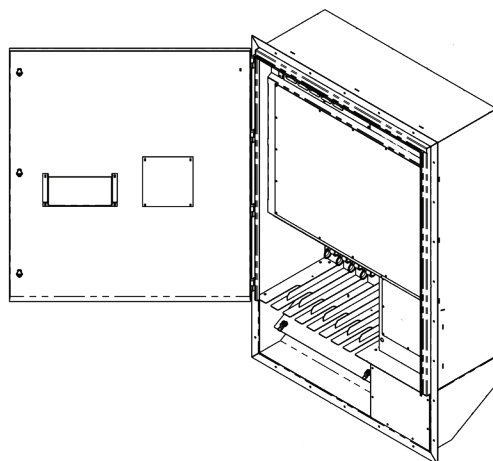

Large: 51" x 78" x 21.375"

**Image 3-4 – Flange-mount Cabinet Sizes**

**NOTE:**

*When used as a docking station, the Trystar GEN 3 Series Enclosure is designed for exterior installation only. All apertures connecting the cabinet interior to the building interior should be sealed to avoid the intrusion of carbon monoxide (CO) from an adjacent generator. Inhaling exhaust can cause serious medical conditions, including death.*

**Wall-mount Enclosures**

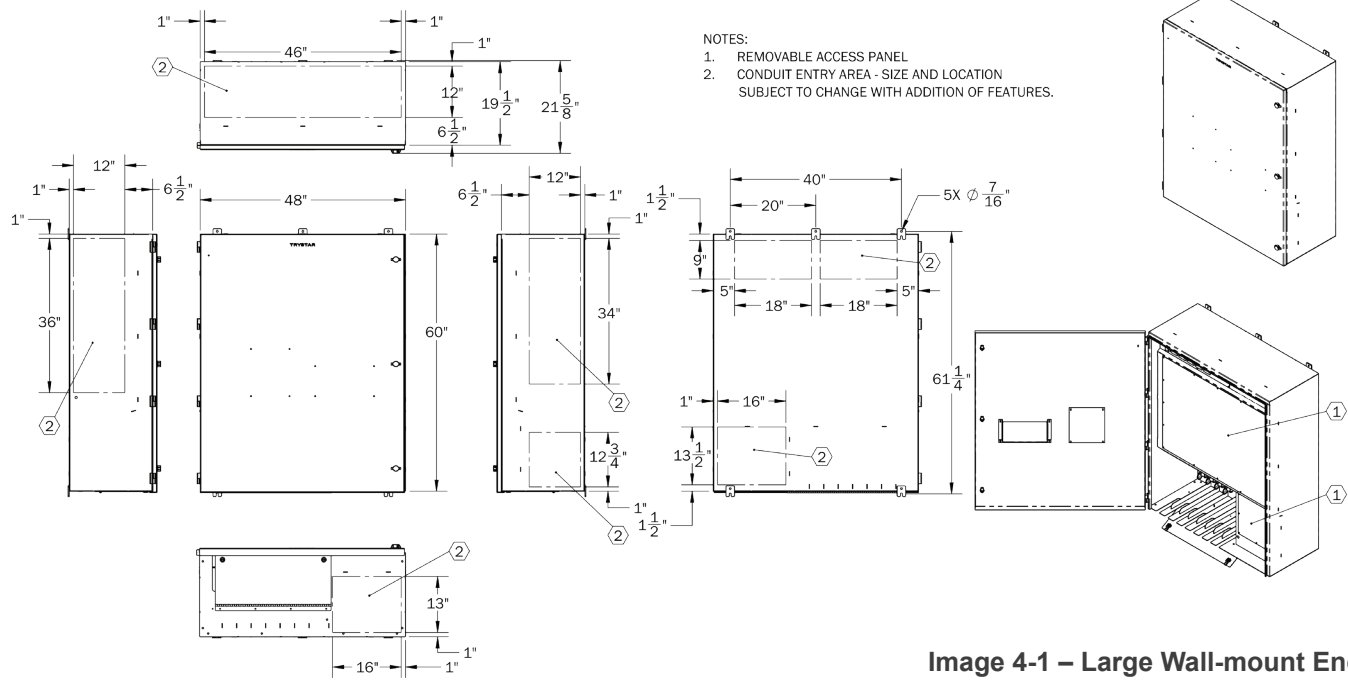

**Image 4-1 – Large Wall-mount Enclosure**

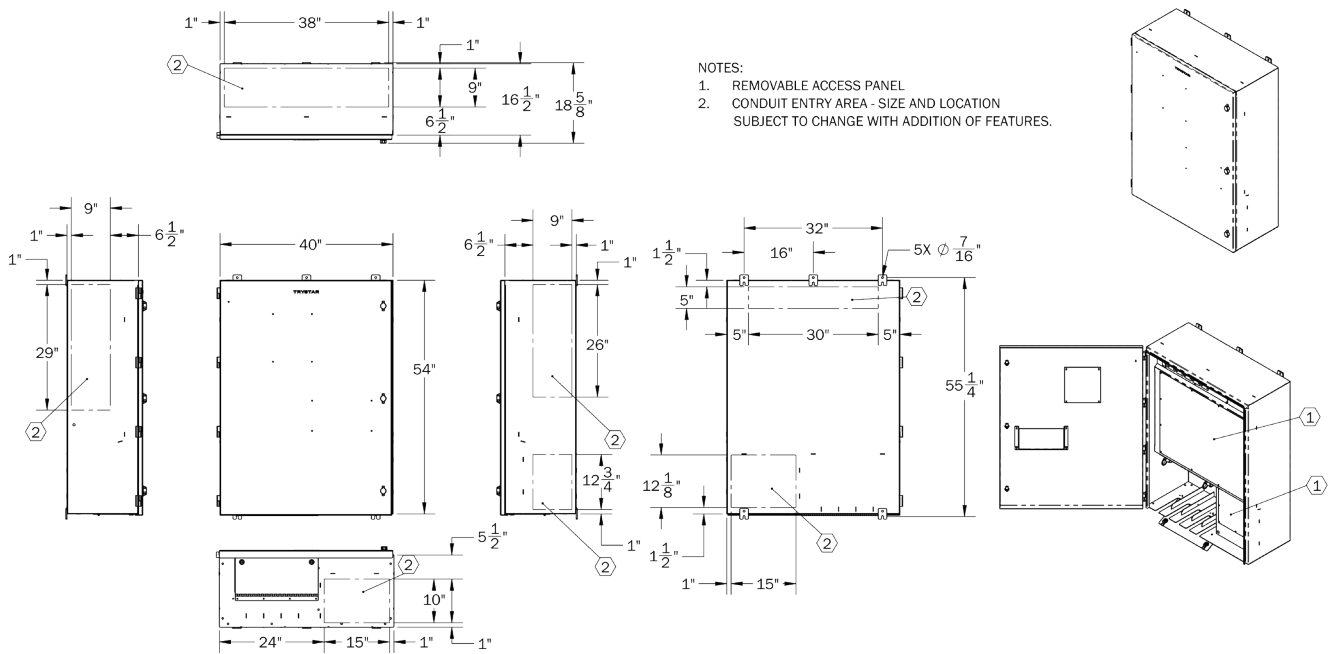

**Image 4-2 – Medium Wall-mount Enclosure**

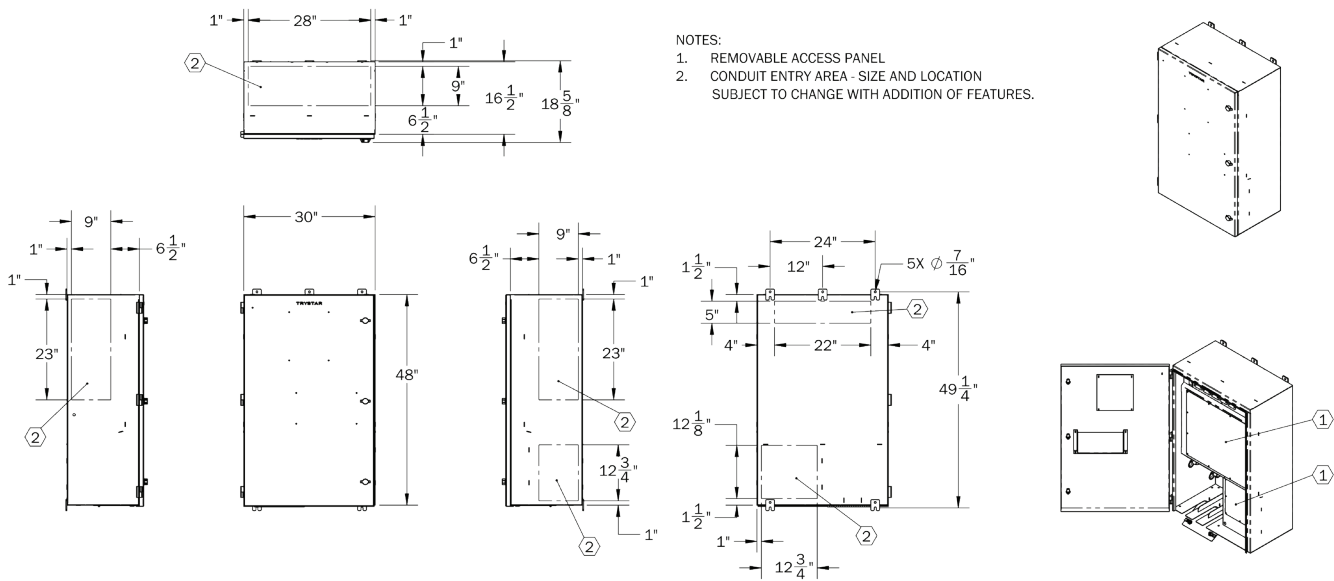

Image 4-3 – Small Wall-mount Enclosure

Wall-mount Enclosures w/Leg Kit

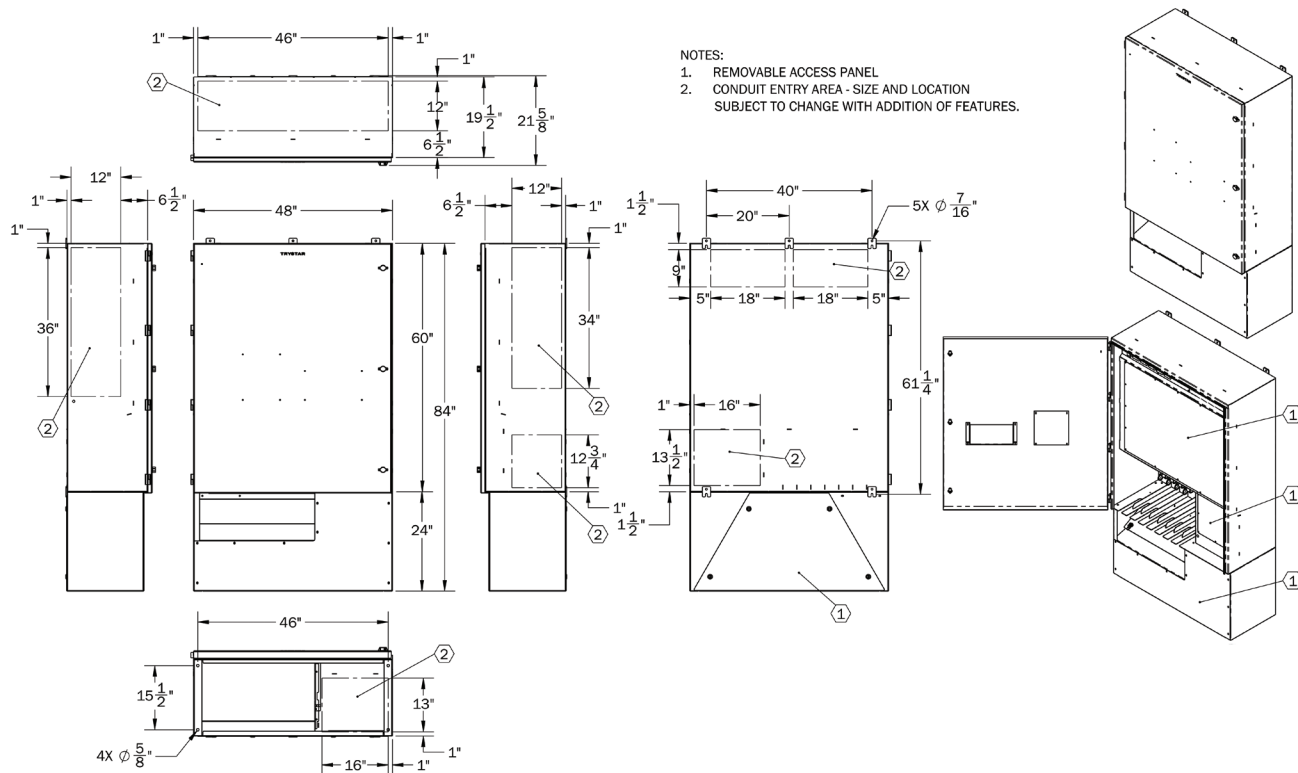
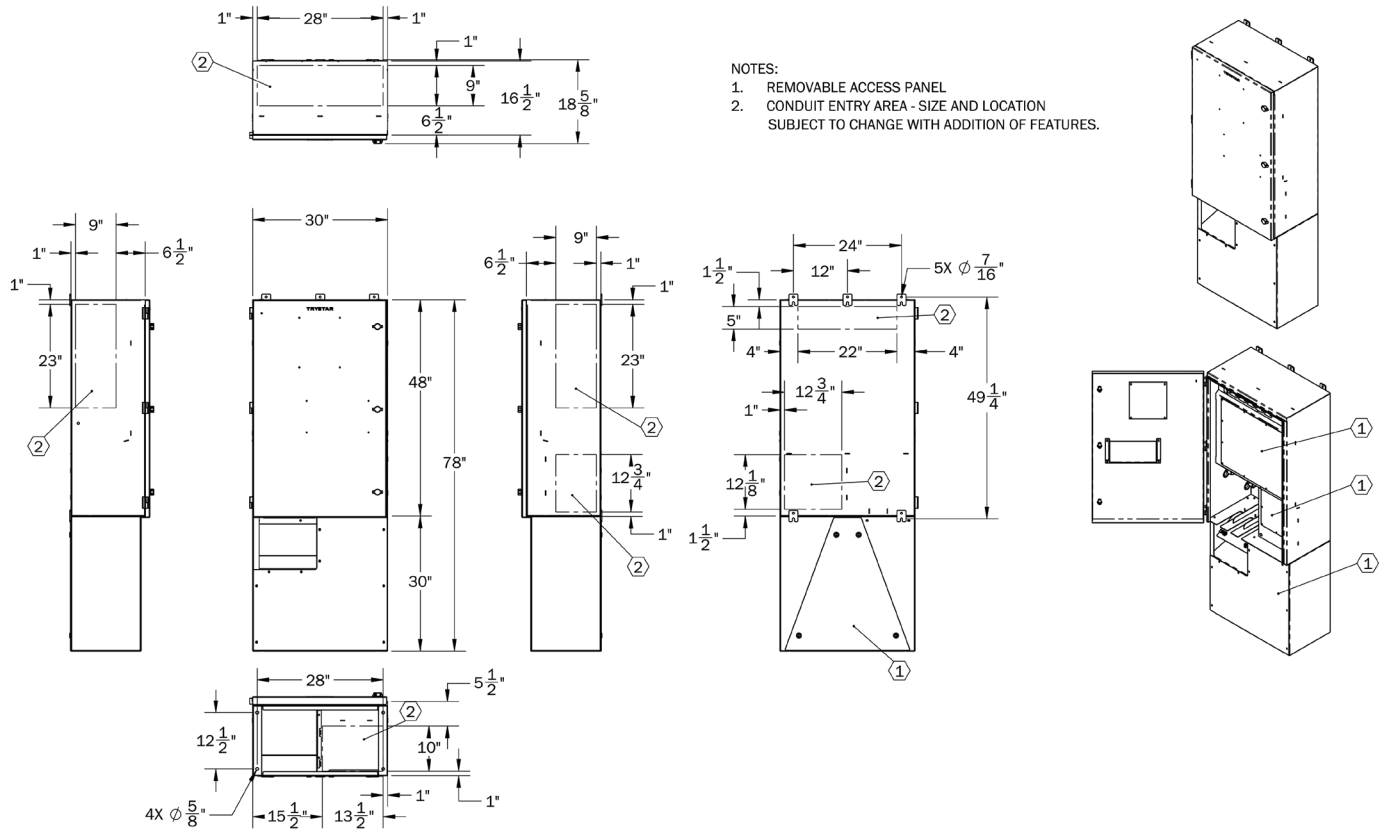
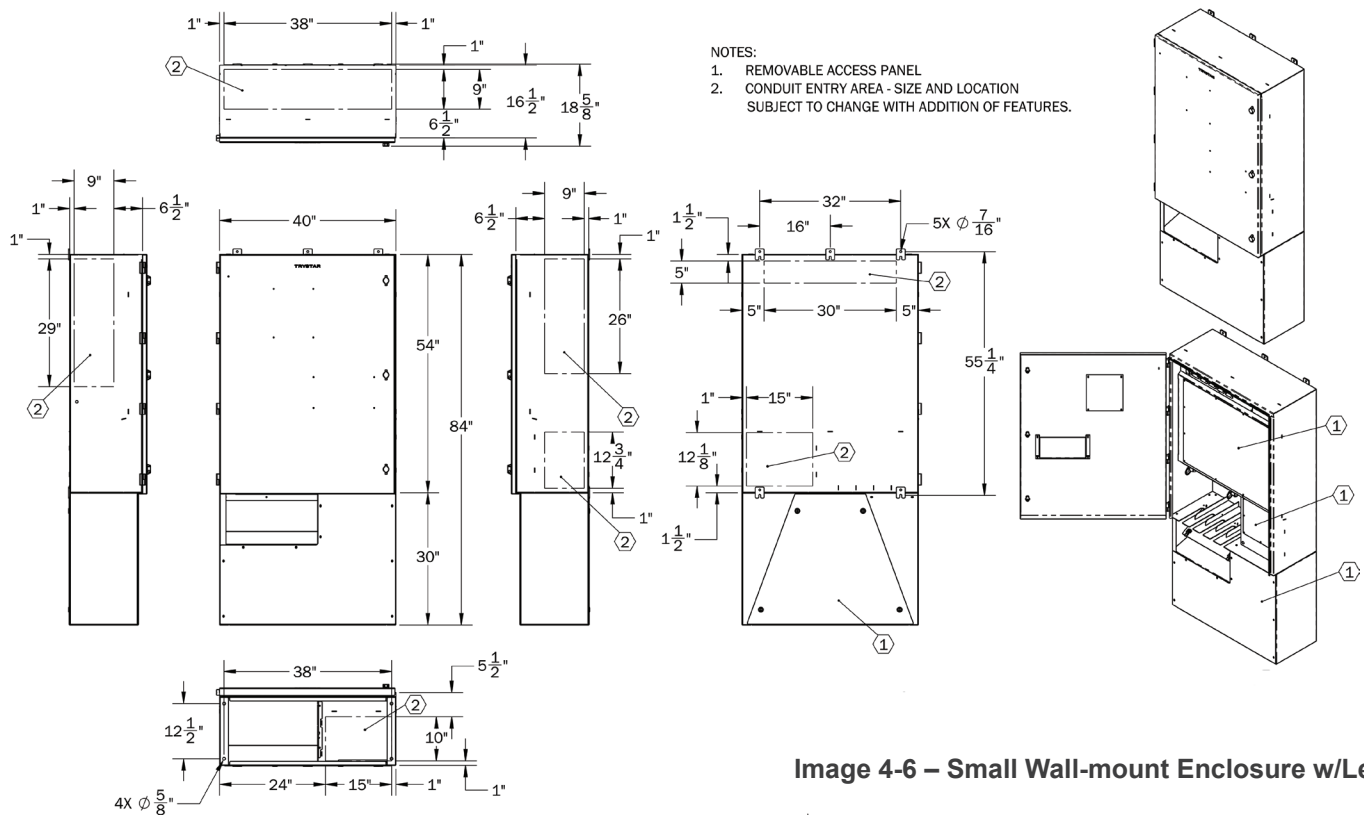

Image 4-4 – Large Wall-mount Enclosure w/Leg Kit

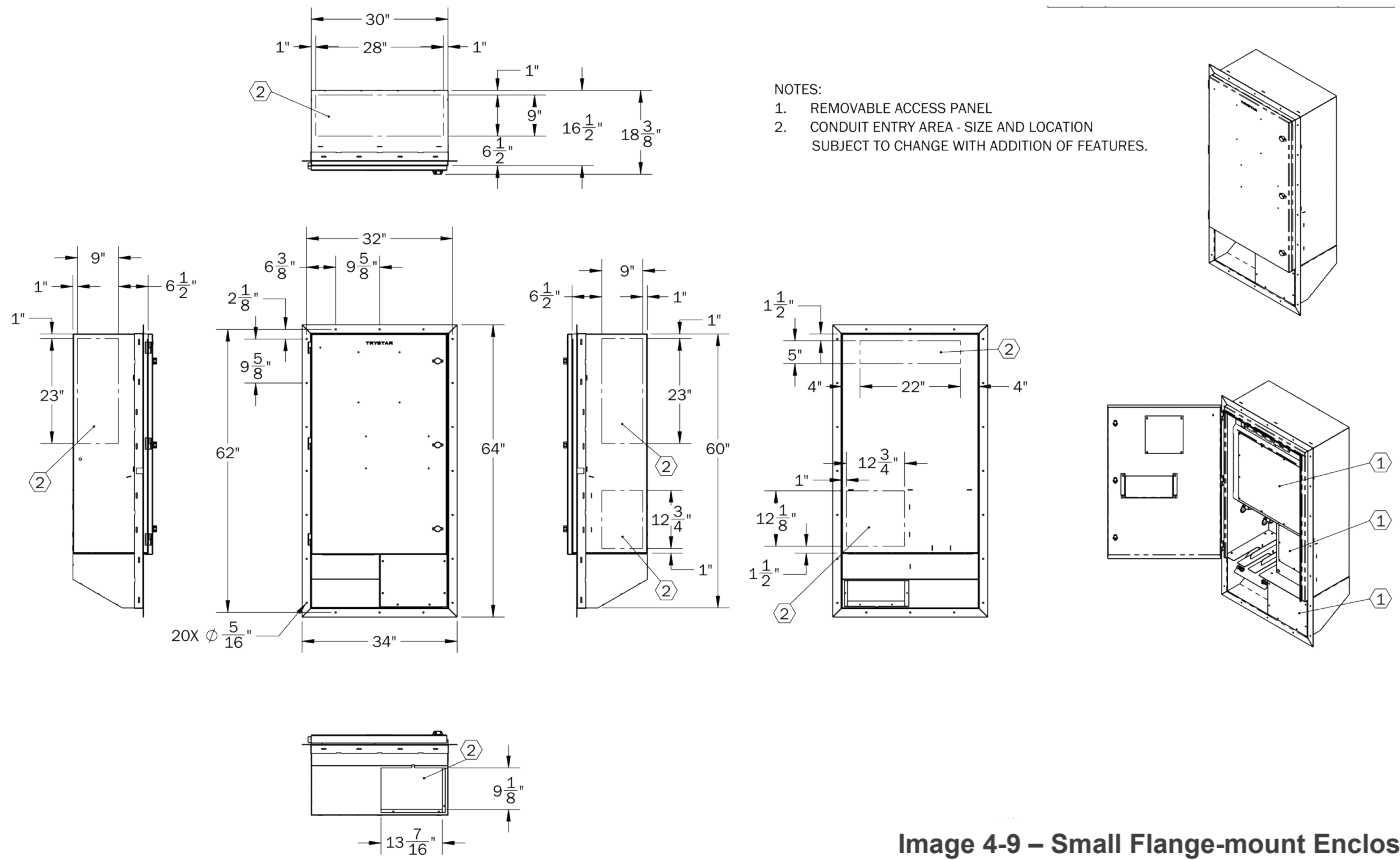

**Image 4-5 – Medium Wall-mount Enclosure w/Leg Kit**



**Image 4-6 – Small Wall-mount Enclosure w/Leg Kit**





**Image 4-9 – Small Flange-mount Enclosure**

## 5—INSTALLATION PROCEDURES

### Large Enclosures

#### Conduit Locations:

Before hanging the cabinet, it is important to note all the conduit locations available for installation. Accessibility may vary upon the GEN 3 Series Enclosure features and accessories specified. While you may have designated your preferred conduit entry location when you placed your order, it is advisable to remove the access panels and inspect the cabinet interior to ensure your configuration will accommodate your installation plan. All wall mount cabinet conduit locations are located on the top, bottom, rear, and sides of each cabinet.

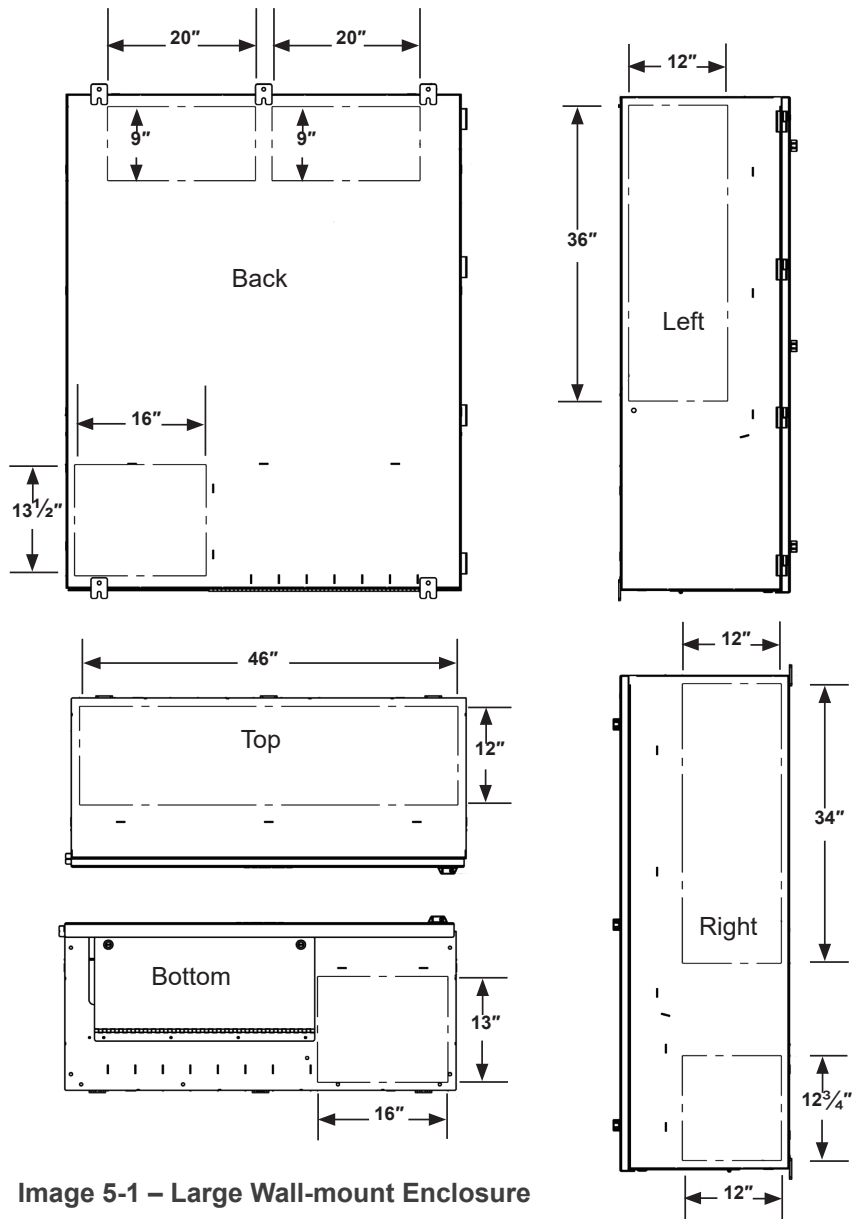

**NOTE:**

Before locating/drilling GEN 3 Series Enclosure mounting holes into a substrate, check conduit locations and interior of GEN 3 cabinet to ensure the internal hardware aligns with the location and design of your installation plan. Conduit should be sized to cable rating.

Image 5-1 – Large Wall-mount Enclosure

Medium Enclosures

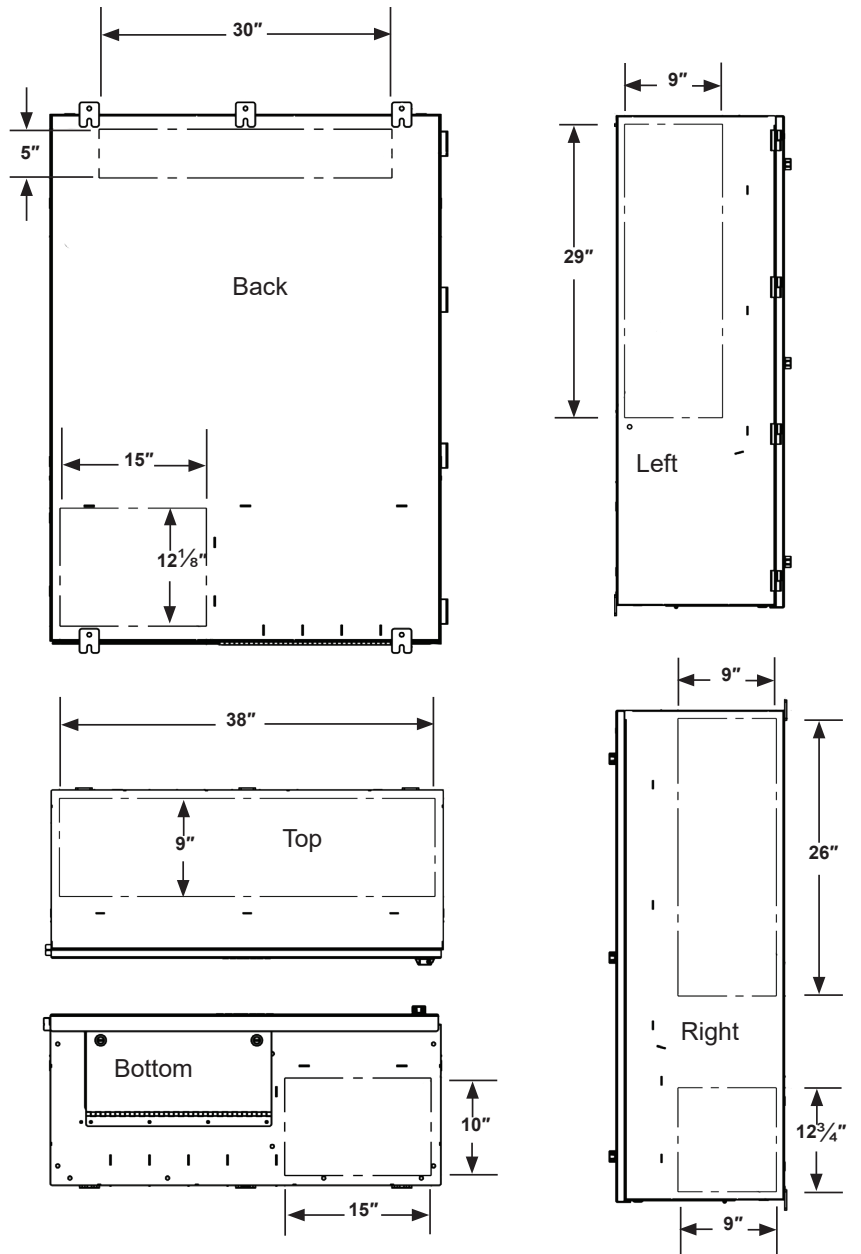

**NOTE:**

*If the rear conduit panel is to be used, cut the appropriate conduit holes in the panel and ensure access for running conduit prior to hanging the cabinet.*

Image 5-2 – Medium Wall-mount Enclosure

Small Enclosures

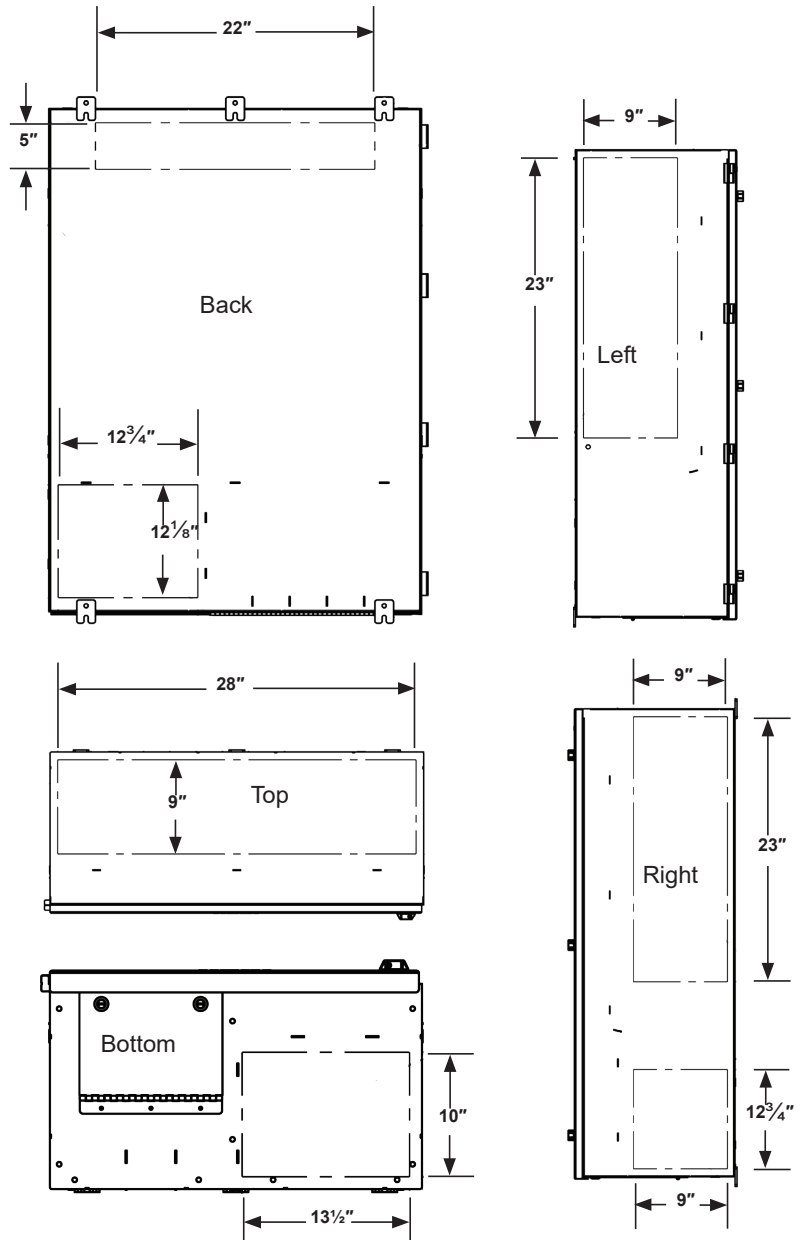

Image 5-3 – Small Wall-mount Enclosure

|  |  |
|--|--|
| <p>TRANSFER SWITCH<br/>POWER INLET<br/><b>CAUTION</b><br/>To avoid electric shock, connect<br/>in the following sequence:<br/>1: GROUND<br/>2: NEUTRAL<br/>3: PHASE A<br/>4: PHASE B<br/>5: PHASE C<br/>Reverse sequence must be used<br/>for disconnecting.</p>  | <p>For power inlet only.<br/>Not for use as an outlet.<br/>200A 480Y/277V 3Ø 60Hz<br/>TRYSTAR, LLC<br/>65K SCCR<br/>5 - 95% Humidity<br/>Ambient Temperature of 40 Deg C</p> |
|--|--|

Image 5-4 – Nameplate Example

Reconfirm Correct Product

Recheck the cabinet nameplate against the specification document and verify that it is the correct line and load voltage for the application and other specifications

Large Enclosures w/Leg Kit

Conduit Locations:

Before hanging the cabinet, it is important to note all the conduit locations available for installation. Accessibility may vary upon the GEN 3 Series Enclosure features and accessories specified. While you may have designated your preferred conduit entry location when you placed your order, it is advisable to remove the access panels and inspect the cabinet interior to ensure your configuration will accommodate your installation plan. All wall mount cabinet conduit locations are located on the top, bottom, rear, and sides of each cabinet.

**NOTE:**  
*Before locating/drilling GEN 3 Series Enclosure mounting holes into a substrate, check conduit locations and interior of GEN 3 cabinet to ensure the internal hardware aligns with the location and design of your installation plan. Conduit should be sized to cable rating.*

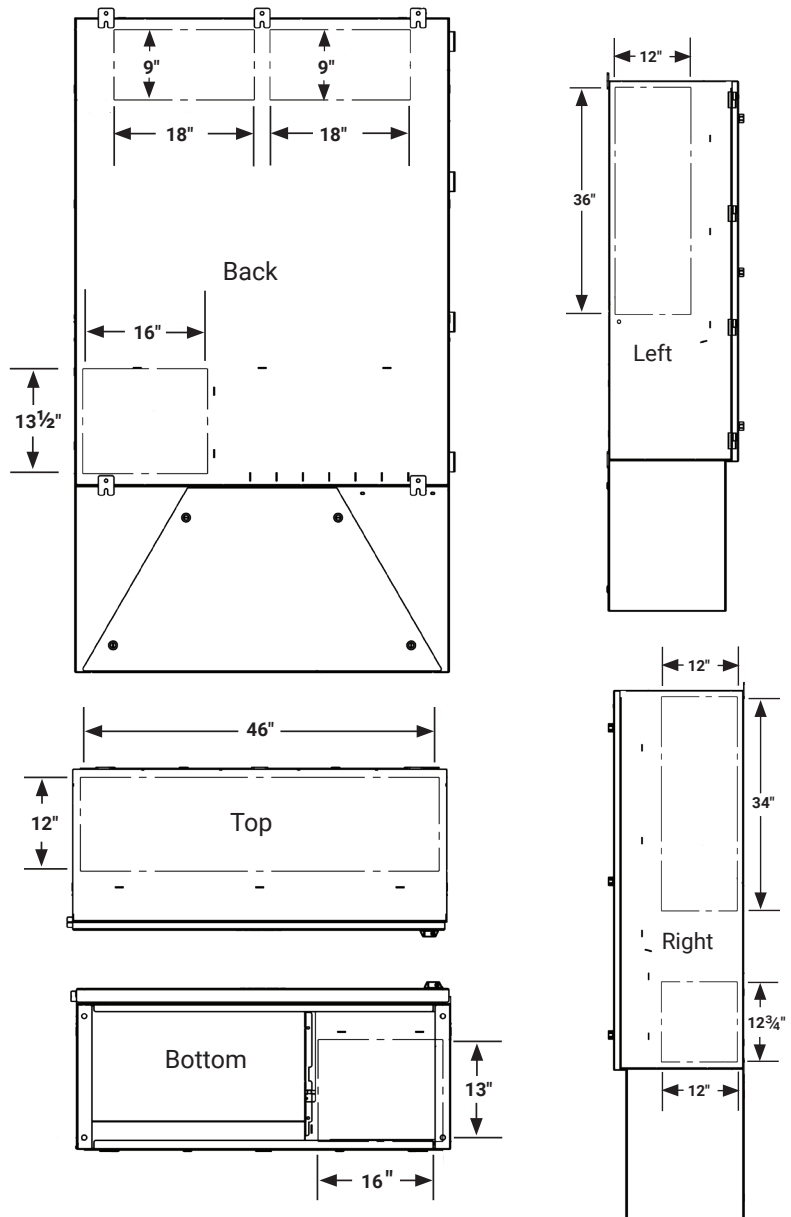
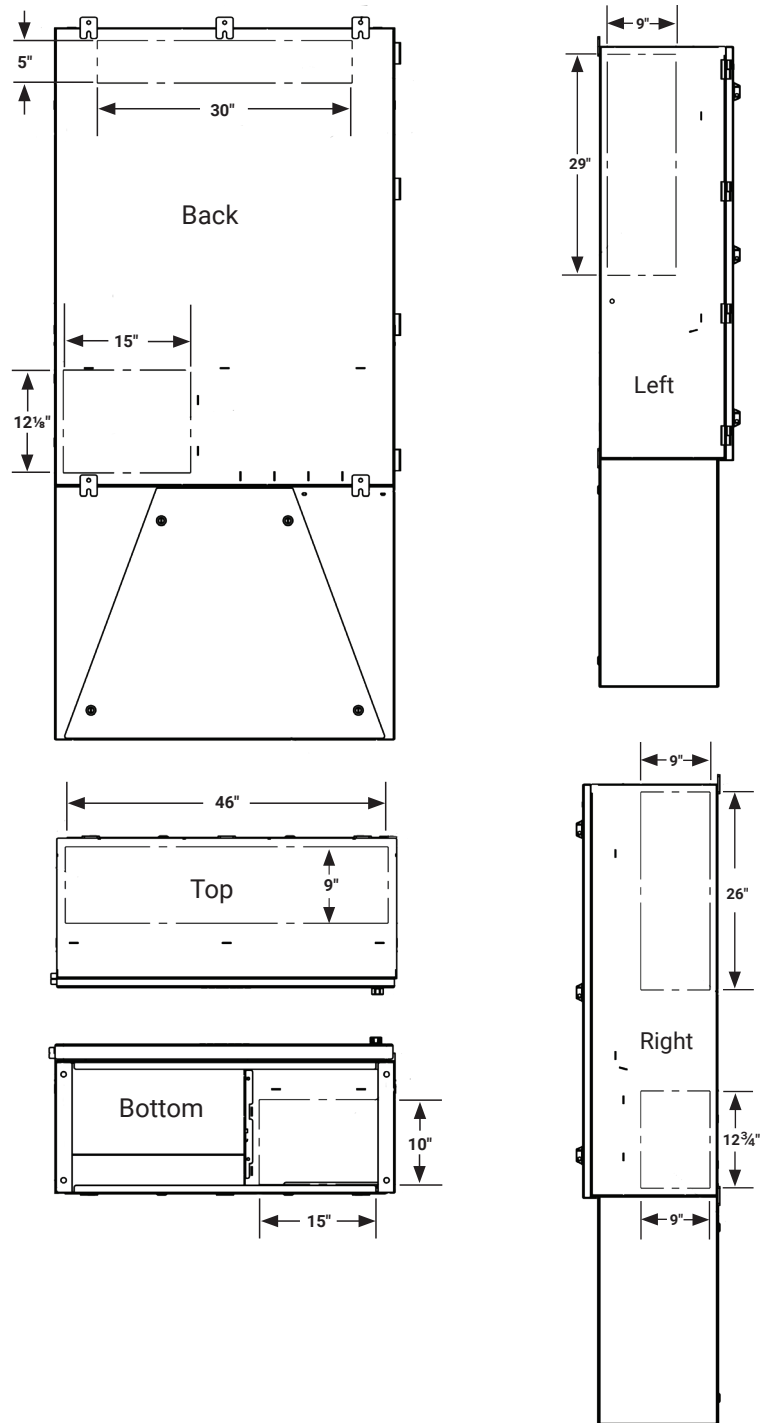

Image 5-5 – Large Wall-mount Enclosure w/Leg Kit

Medium Enclosures w/Leg-Kit



**NOTE:**

*If the rear conduit panel is to be used, cut the appropriate conduit holes in the panel and ensure access for running conduit prior to hanging the cabinet.*

Image 5-6 – Medium Wall-mount Enclosure w/Leg Kit

**Small Enclosures w/Leg-Kit**

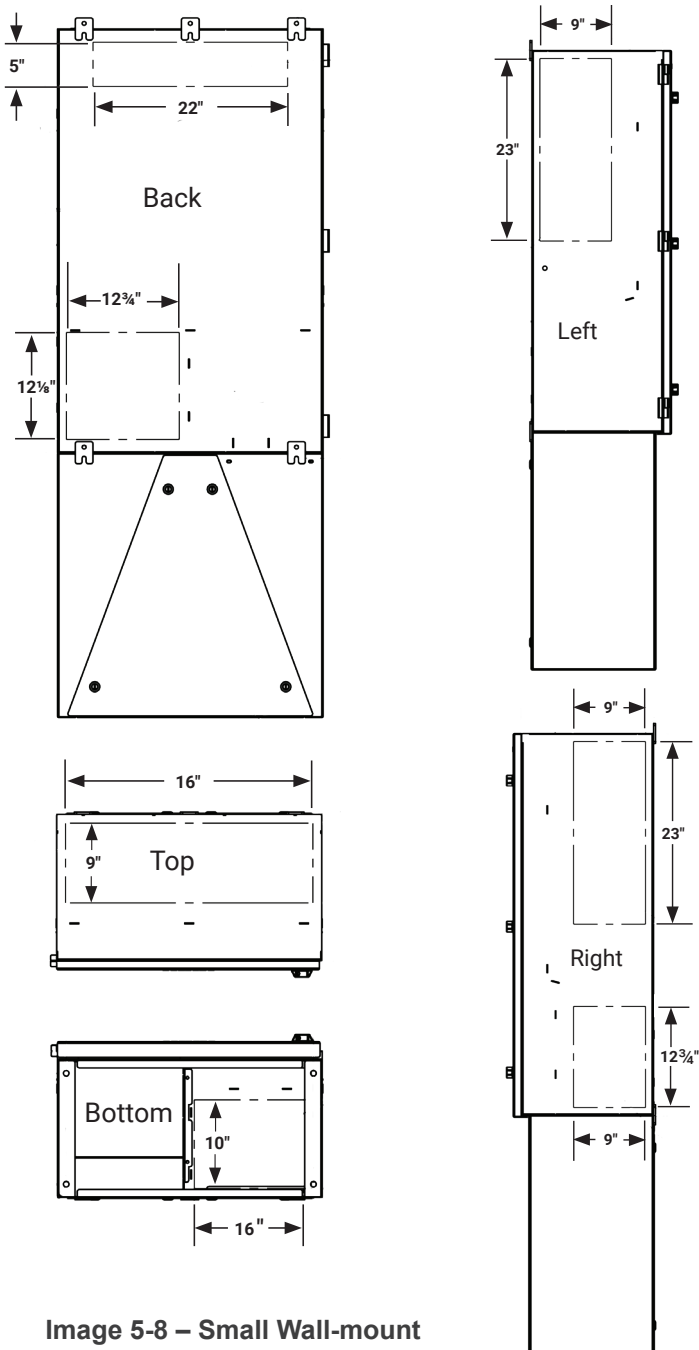

**Image 5-8 – Small Wall-mount Enclosure w/Leg Kit**

|   |   |
|---|---|
| <p>TRANSFER SWITCH<br/>POWER INLET</p> <p><b>CAUTION</b></p> <p>To avoid electric shock, connect in the following sequence:</p> <ol style="list-style-type: none"> <li>1: GROUND</li> <li>2: NEUTRAL</li> <li>3: PHASE A</li> <li>4: PHASE B</li> <li>5: PHASE C</li> </ol> <p>Reverse sequence must be used for disconnecting.</p> | <p>For power inlet only.<br/>Not for use as an outlet.</p> <p>200A 480Y/277V 3Ø 60Hz</p> <p><b>TRYPSTAR, LLC</b></p> <p>65K SCCR</p> <p>5 - 95% Humidity</p> <p>Ambient Temperature of 40 Deg C</p> |
|---|---|

**Image 5-7 – Nameplate Example**

**Reconfirm Correct Product**

Recheck the cabinet nameplate against the specification document and verify that it is the correct line and load voltage for the application and other specifications

Large Flange-mount Enclosures

Conduit Locations:

Before hanging the cabinet, it is important to note all the conduit locations available for installation. Accessibility may vary upon the GEN 3 Series Enclosure features and accessories specified. While you may have designated your preferred conduit entry location when you placed your order, it is advisable to remove the access panels and inspect the cabinet interior to ensure your configuration will accommodate your installation plan. All wall mount cabinet conduit locations are located on the top, bottom, rear, and sides of each cabinet.

**NOTE:**

*Before locating/drilling GEN 3 Series Enclosure mounting holes into a substrate, check conduit locations and interior of cabinet to ensure the internal hardware aligns with the location and design of your installation plan.*

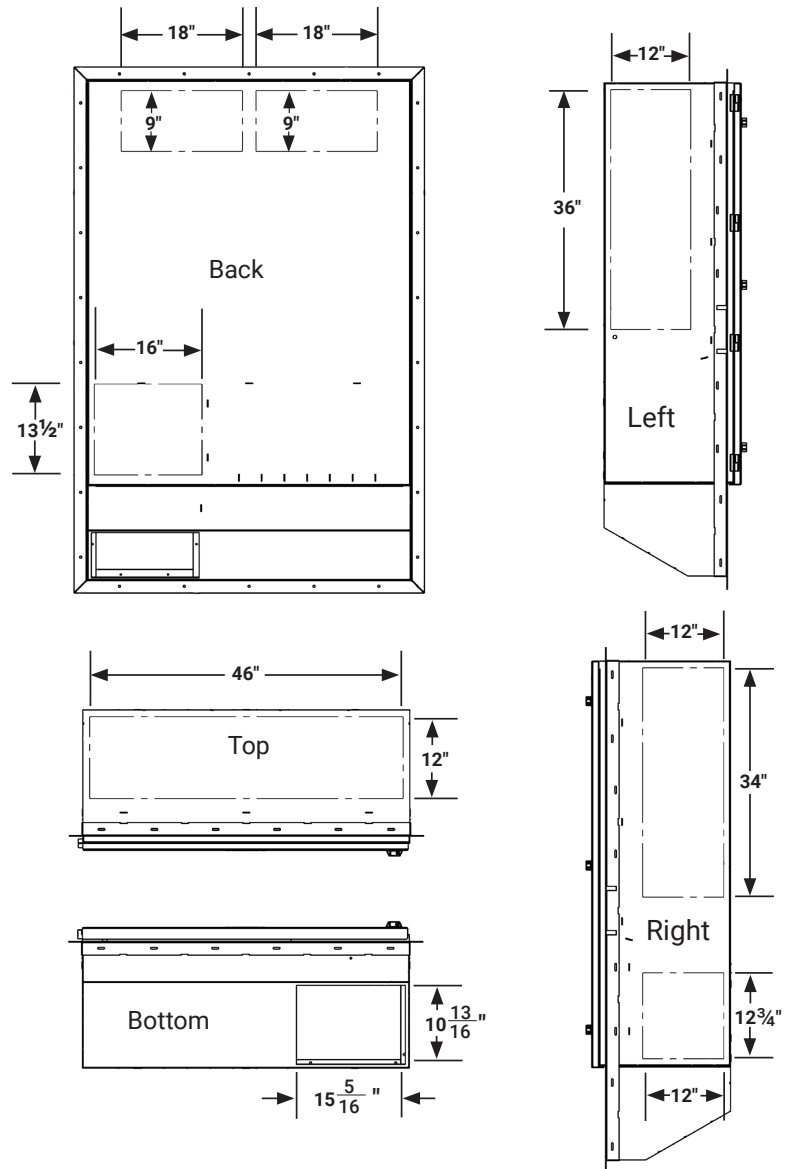
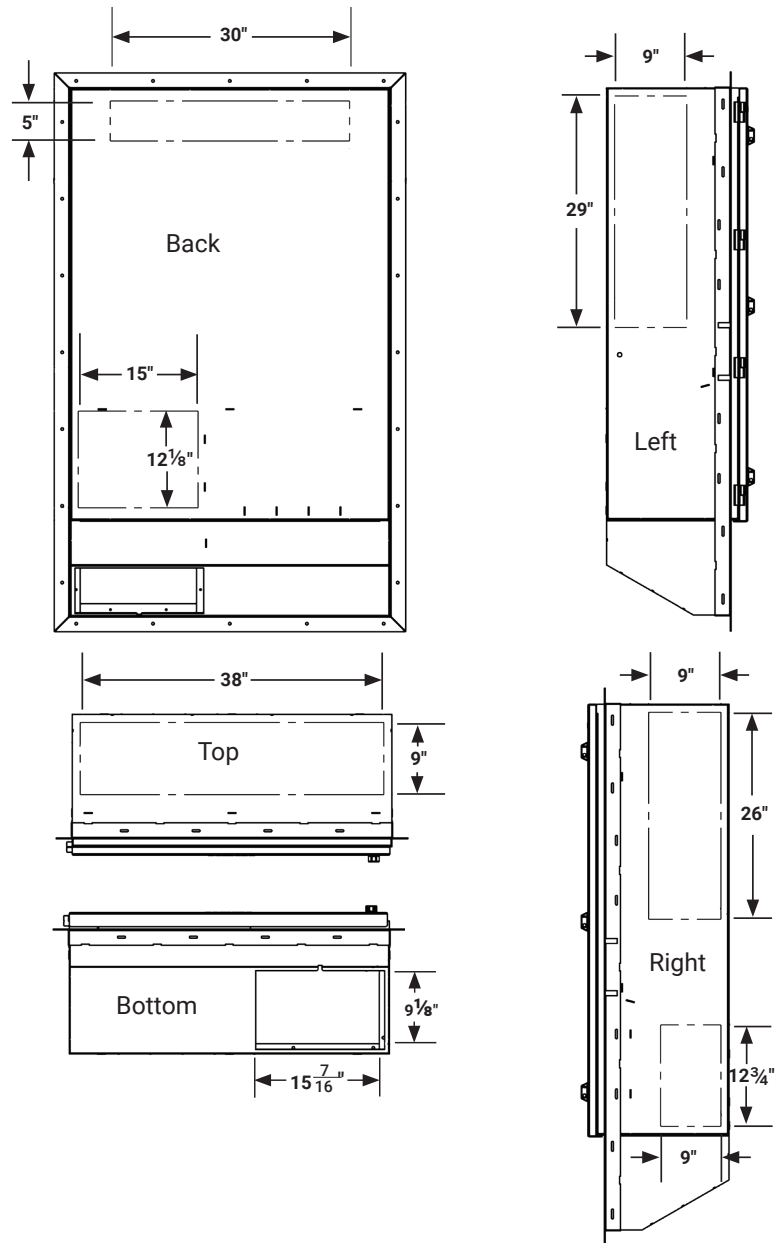

Image 5-9 – Large Flange-mount Enclosure

Medium Flange-mount Enclosures



**NOTE:**

*If the rear conduit panel is to be used, cut the appropriate conduit holes in the panel and ensure access for running conduit prior to hanging the cabinet.*

Image 5-10 – Medium Flange-mount Enclosure

Small Flange-mount Enclosures

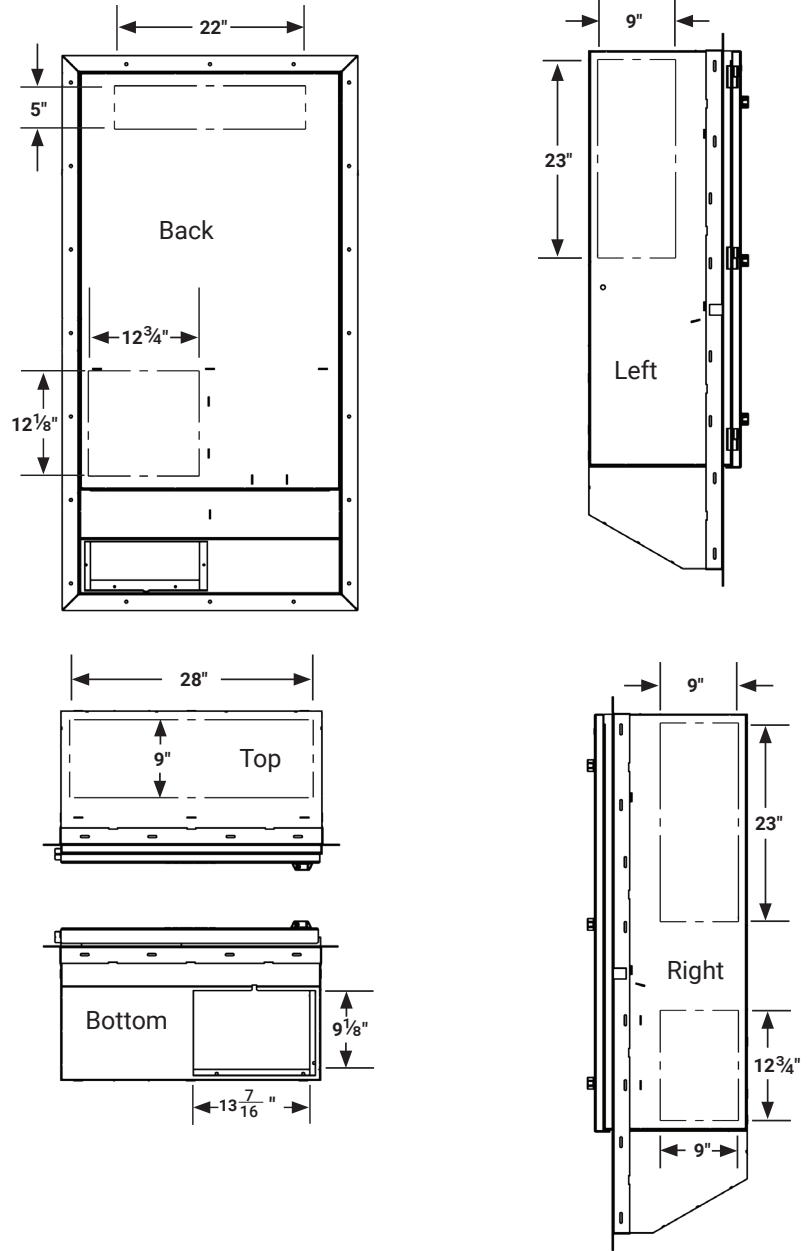

Image 5-11 – Small Flange-mount Enclosure

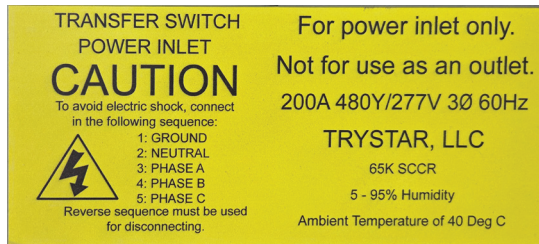

Image 5-12 – Nameplate Example

Reconfirm Correct Product

Recheck the cabinet nameplate against the specification document and verify that it is the correct line and load voltage for the application and other specifications

## Bolts, Anchors, Hardware, and Substrates

NOTE: All fastener components should be suitable for outdoor use or the environment in which they are used. Steel-based lock nuts can be substituted for lock washers and Hex nuts.

## Wall-mount Enclosures

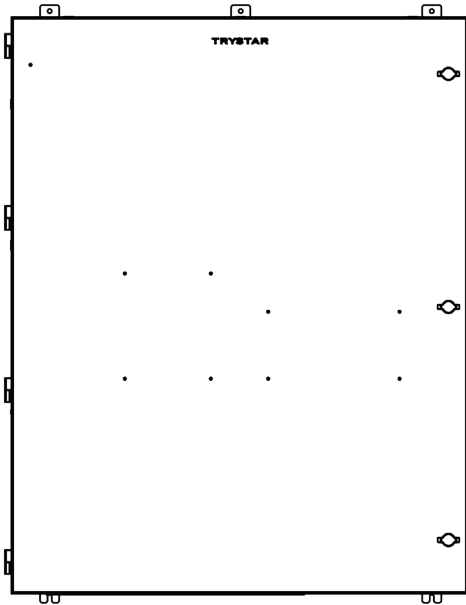

Image 5-13 – Wall-mount Enclosure

### Wall Fasteners:

- (5) 7/16" masonry expansion anchors or Hex bolts suitable to substrate
- Washers, lock washers and nuts rated for intended use

All wall mount cabinets can be mounted to substantial block, brick and concrete as well as steel or aluminum. Regardless of size, all wall mount cabinets have five bolt locations: three on the top and two on the bottom. The hole diameters accommodate 7/16" masonry expansion anchors or 7/16" Hex bolts.

For fastening the enclosure to a steel or aluminum wall or Unistrut®, use bolts with coatings and tensile and shear strengths suitable for the installation. The bolts should be fastened with locking features to prevent loosening over time. Lock nuts (e.g., Nylock®), thread locker (Loctite® 242/271), and lock washers are appropriate. Use washers to help prevent damage to the cabinet mounting tabs and substrate surface. Torque bolts to the manufacturer's specifications.

For fastening the enclosure to a masonry wall like brick, concrete, or concrete block, use five appropriately-rated 7/16" wall anchor bolts suitable to the environment and installation needs. Anchor bolt types necessarily vary depending if the substrate is brick, concrete or concrete block. If used, wedge and sleeve anchors should be tapped in flush with the aggregate surface and then tightened, torqued and set before fastening the enclosure to the bolt heads. Follow manufacturer anchor torque settings to avoid pullout.

## Unistrut® Hardware System

### Unistrut® Hardware System

Unistrut (or strut channel) is a modular framing system used in construction and electrical/mechanical installations for mounting, bracing, and supporting equipment, conduit, and cabinets. It is often used as a structural framework to mount GEN 3 Enclosures on masonry, metal and other surfaces. It can provide a more flexible installation in terms of fastener alignment and installation forgiveness. Furthermore, since the components are bolted together, welding is not involved. Trystar recommends using a stainless steel or galvanized steel strut channel with hardware (strut nuts, brackets, fittings, anchors and bolts) that is appropriate for the installation and heavy enough to support up to 480 lbs.

Using a masonry wall as an example, you could use two (12 to 14-gauge) horizontal strut channels, one aligned with the top holes and one with the bottom holes of the cabinet. Then you would:

- Choose installation-site appropriate, 5/16" load-rated expansion anchors. Each mounting point should be capable of holding 120 lbs. minimum

- The typical embedment depth would be 1.75" to 2.5" depending on load and anchor specifications
- Locate, mark, and drill holes for the anchors ensuring they are level. Install anchors per manufacturer specifications/instructions
- Mount each Unistrut channel to the anchors
- Insert strut nuts into each channel aligned with the cabinet mounting tab holes
- Insert 5/16" stud bolts with washers through the cabinet mounting tabs and into the strut nuts and tighten securely

It is essential to check the manufacturer load charts for both expansion anchors and Unistrut. Additionally, it is crucial to fasten the cabinet to the Unistrut securely. Use locking washers or thread lock compound to prevent bolts from loosening over time.

**Wall-mount w/Leg Kit Enclosures**

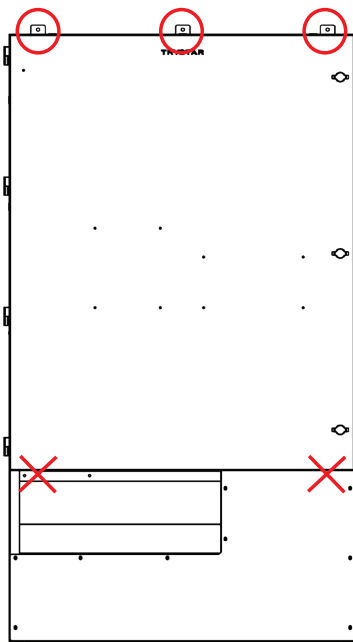

**Image 5-14 – Wall-mount Enclosure w/Leg Kit**

**Wall Fasteners**

- (3) 7/16" concrete screws, Hex bolts or stud bolts suitable to substrate or framing system
- Washers, lock washers, and nuts

**Concrete Pad Fasteners**

- (4) 5/8" expansion anchor bolts
- Washers, lock washers, and nuts rated for intended use

**Cabinet to Leg Fasteners (Provided)**

- (8) 3/8" Bolts, washers, lock washers, and nuts
- (2) 1/4" Bolts, washers, lock washers, and nuts

All wall mount with leg kit enclosures feature five vertical substrate bolt locations on the upper cabinet: three on the top and two on the bottom. You do not need to use the bottom two bolt locations because the leg kit (pedestal base) provides the needed support.

The vertical substrate tab holes accommodate 7/16" Hex bolts (metal wall) or concrete screws (masonry wall), e.g., Tapcon®. Hardware for fastening the upper cabinet to the leg kit is provided and includes (8) 3/8" and (2) 1/4" Hex bolts, washers, lock washers and nuts. Knockout holes in the upper cabinet are provided and the leg kit is pre-drilled. Use three appropriately-rated 7/16" Hex-washer-head concrete screws suitable to the environment and installation needs.

The expansion anchors, Hex bolts and stud bolts should have locking features to prevent loosening over time. Lock nuts (e.g., Nylock®), thread locker (Loctite® 242/271), and lock washers (if using Hex nuts) are appropriate. Use washers to help prevent damage to the cabinet and substrate surface. Anchors, Hex bolts, and stud bolts (and other fasteners) should be suitable for the installation. Follow the anchor manufacturer's installation instructions (on the packaging) and any authority having jurisdiction.

For fastening the enclosure to a brick, concrete, or concrete block wall, use three appropriately-rated 7/16" Hex-washer-head concrete screws

**Flange-mount Enclosures**

suitable to the environment and installation needs. Similarly, (but to a metal wall or Unistrut), use 7/16" Hex bolts or stud bolts respectively.

To fasten the leg kit (pedestal) to a masonry substrate such as a concrete pad, use four 5/8" expansion anchor bolts (e.g., wedge or sleeve).

**Unistrut® Hardware System**

**Unistrut® Hardware System (Refer to Pg. 23)**

**Flange-mount Enclosures**

**Wall Fasteners**

- 5/16" Hex bolts, lag bolts, structural screws, or concrete screws suitable to substrate
- Washers, lock washers, and nuts rated for intended use

All flange mount cabinets can be mounted to substantial concrete block, brick and concrete as well as steel or aluminum. They can also be mounted to a substantial wood framework inside a masonry opening. Regardless of size, all flange mount cabinets have multiple fastener locations. The hole diameters accommodate 5/16" Hex bolts, lag bolts, structural and concrete screws.

For fastening the enclosure to a vertical steel or aluminum wall, use Hex bolts with coatings and tensile and shear strengths suitable for the installation. The Hex bolts should be fastened with locking features to prevent loosening over time. Lock nuts (e.g., Nylock®), thread locker (Loctite® 242/271), and lock washers are appropriate. Use washers to help prevent damage to the cabinet mounting tabs and substrate surface. Torque fasteners to the manufacturer's specifications. For fastening the enclosure to a vertical masonry substrate (wall) like brick, concrete, or concrete block, use appropriately-rated 5/16" concrete screws suitable to the environment and installation needs. If the masonry opening is appropriately framed-out with substantial wood framing members, the enclosure can be fastened to the frame with structural screws or lag bolts.

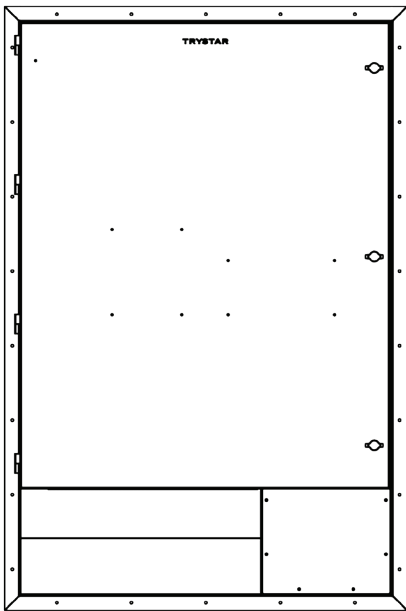

**Image 5-15 – Flange-mount Enclosure**

Mounting Hole Locations and Dimensions  
Wall-mount - Large Cabinet

Mounting Hole Locations and Dimensions - Large Cabinet

Overall Cabinet Dimensions:

Height — 60"

Width — 48"

Depth — 21.625"

The cabinet should be installed onto a stable surface, such as concrete block, concrete, or brick. Alternatively, cabinets can also be mounted on steel or aluminum walls or Unistrut®, provided they are strong enough to support up to 480 lbs.

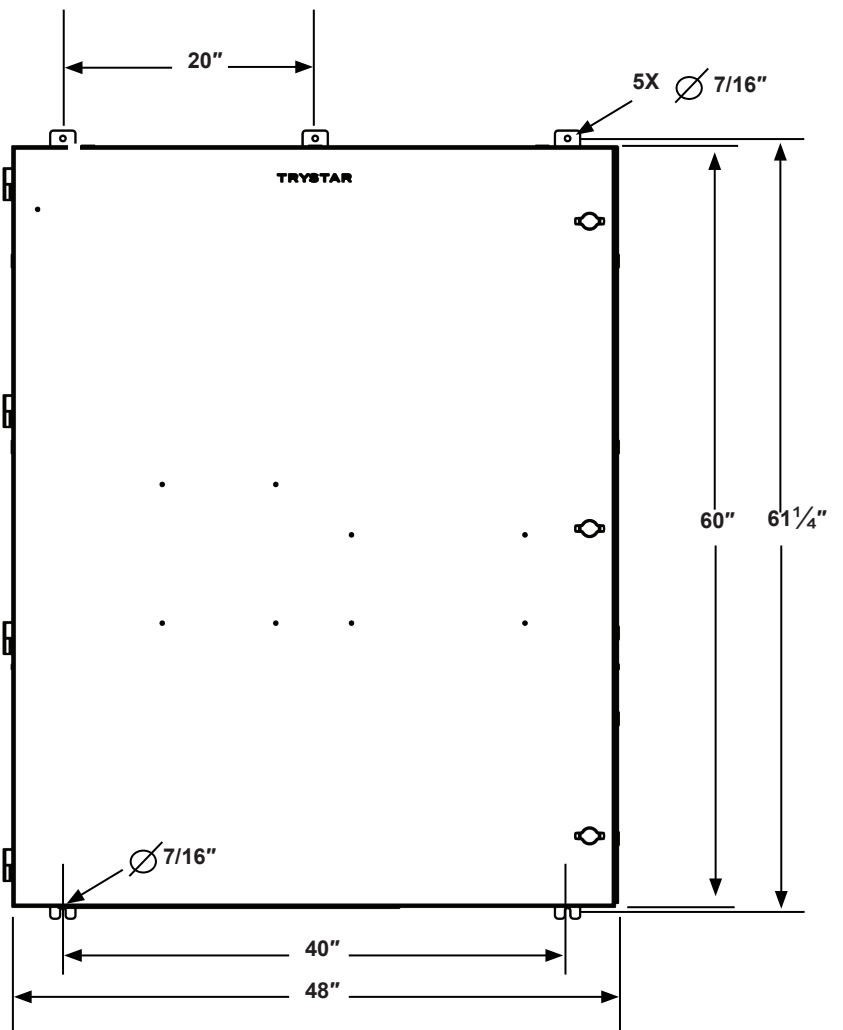

Image 5-16 –Large Wall-mount Cabinet

**Mounting Hole Locations and Dimensions**  
**Wall-mount - Medium Cabinet**

**Mounting Hole Locations and Dimensions - Medium Cabinet**

*Overall Cabinet Dimensions:*

*Height — 54"*

*Width — 40"*

*Depth — 18.625"*

The cabinet should be installed onto a stable surface, such as concrete block, concrete, or brick. Alternatively, cabinets can also be mounted on steel or aluminum walls or Unistrut®, provided they are strong enough to support up to 320 lbs.

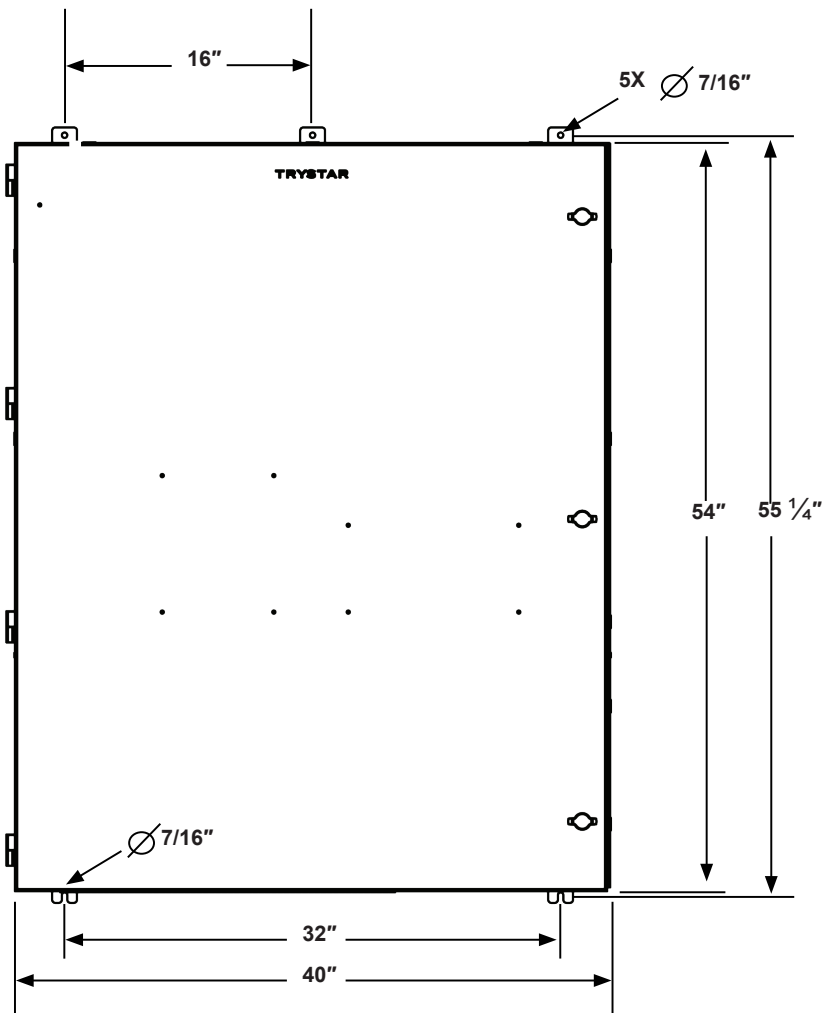

**Image 5-17 –Medium Wall-mount Cabinet**

Mounting Hole Locations and Dimensions  
Wall-mount - Small Cabinet

Mounting Hole Locations and Dimensions - Small Cabinet

Overall Cabinet Dimensions:

Height — 48"

Width — 30"

Depth — 18.625"

The cabinet should be installed onto a stable surface, such as concrete block, concrete, or brick. Alternatively, cabinets can also be mounted on steel or aluminum walls or Unistrut®, provided they are strong enough to support up to 160 lbs.

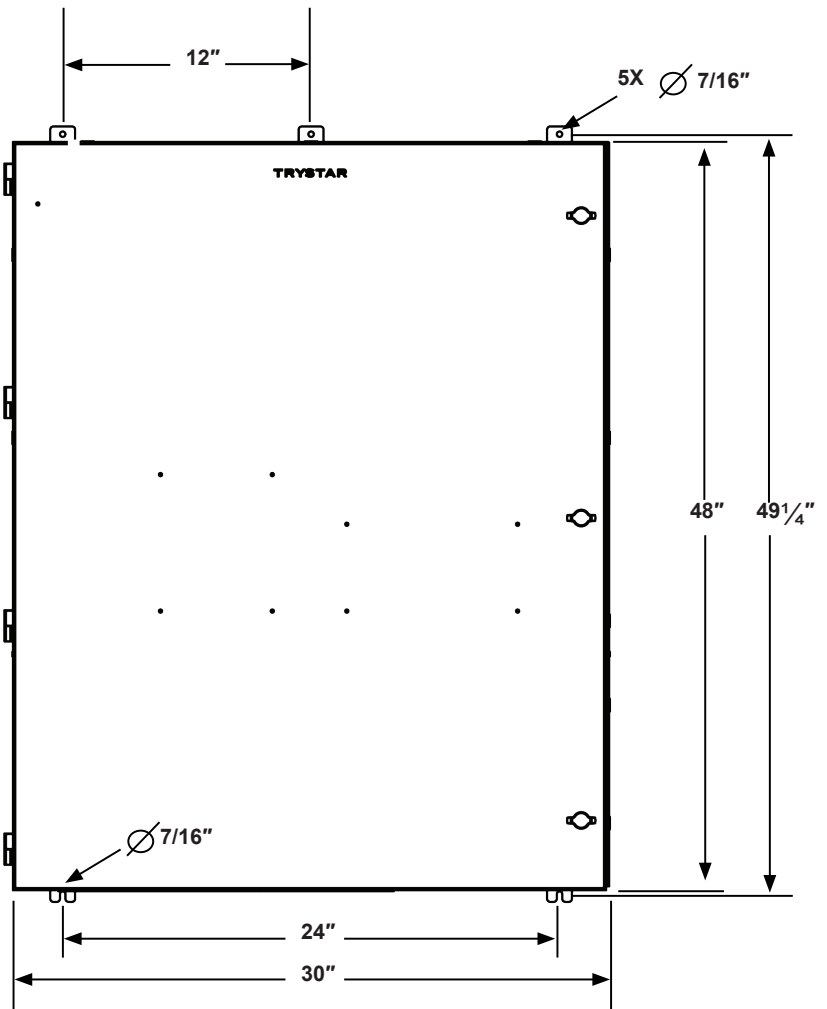

Image 5-18 –Small Wall-mount Cabinet

Mounting Hole Locations and Dimensions  
Wall-mount w/Leg Kit - Large Cabinet

Mounting Hole Locations and Dimensions - Large Cabinet w/Leg  
Kit

Overall Cabinet Dimensions:  
Height — 84"  
Width — 48"  
Depth — 21.375"

The leg kit should be mounted to a stable substrate, such as a concrete pad. Upper cabinet mounting tabs can be mounted to masonry, steel, and aluminum walls for additional stability using Hex-washer-head concrete screws (masonry), Hex bolts (for metal walls) or stud bolts (Unistrut®). See Pg. 24 (Bolts, Anchors, Hardware, and Substrates) and Pg. 23 for information about using Unistrut.

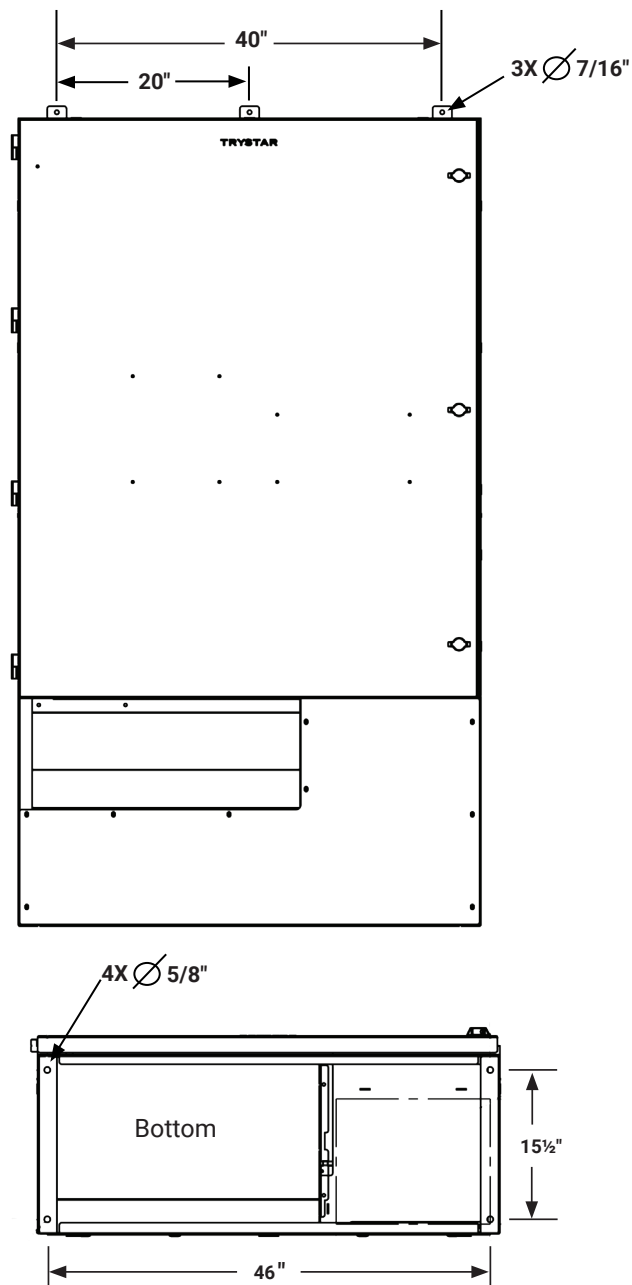

Image 5-19 – Large Cabinet w/Leg Kit

Mounting Hole Locations and Dimensions  
- Medium Cabinet

Mounting Hole Locations and Dimensions - Wall-mount w/Leg Kit  
Medium Cabinet

Overall Cabinet Dimensions:  
Height — 84"  
Width — 40"  
Depth — 18.625"

The leg kit should be mounted to a stable substrate, such as a concrete pad. Upper cabinet mounting tabs can be mounted to masonry, steel, and aluminum walls for additional stability using Hex-washer-head concrete screws (masonry), Hex bolts (for metal walls) or stud bolts (Unistrut®). See Pg. 24 (Bolts, Anchors, Hardware, and Substrates) and Pg. 23 for information about using Unistrut.

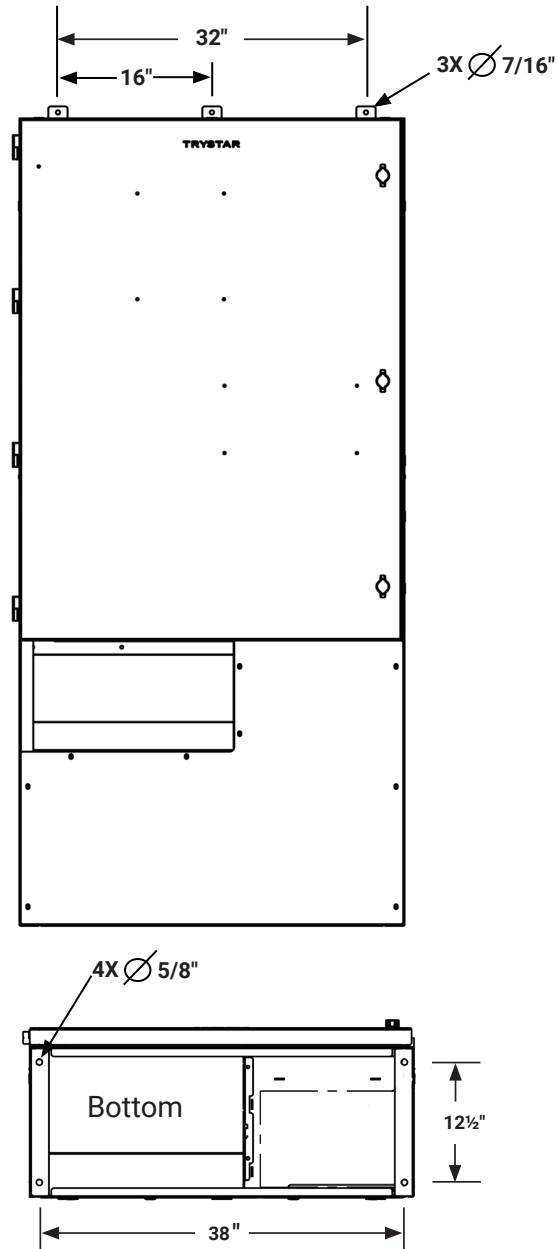

Image 5-20 –Medium Cabinet w/Leg Kit

Mounting Hole Locations and Dimensions  
- Small Cabinet

Mounting Hole Locations and Dimensions - Wall-mount w/Leg Kit  
Small Cabinet

Overall Cabinet Dimensions:  
Height — 78"  
Width — 30"  
Depth — 18.625"

The leg kit should be mounted to a stable substrate, such as a concrete pad. Upper cabinet mounting tabs can be mounted to masonry, steel, and aluminum walls for additional stability using Hex-washer-head concrete screws (masonry), Hex bolts (for metal walls) or stud bolts (Unistrut®). See Pg. 24 (Bolts, Anchors, Hardware, and Substrates) and Pg. 23 for information about using Unistrut.

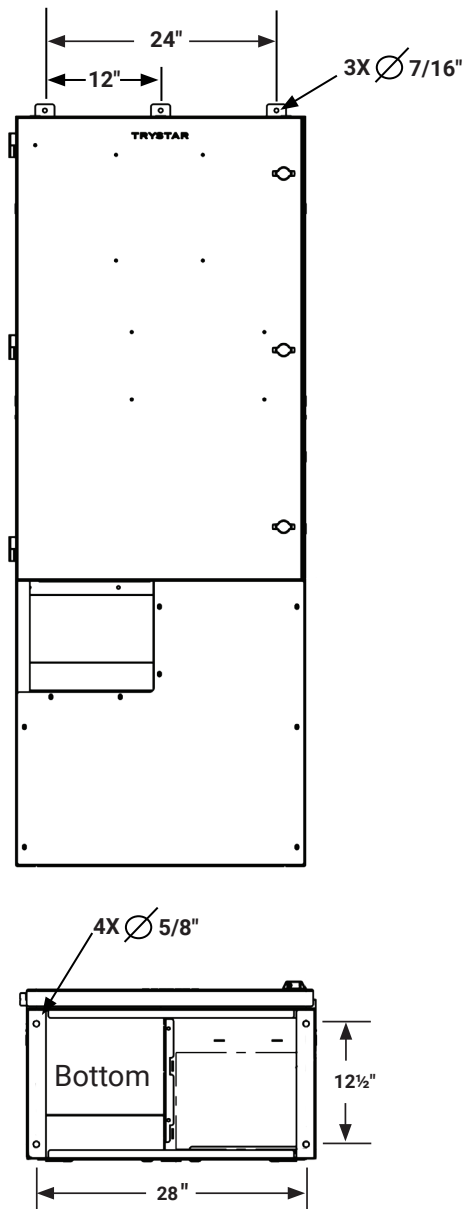

Image 5-21 –Small Cabinet w/Leg Kit

Mounting Hole Locations and Dimensions  
- Large Flange-mount Cabinet

Mounting Hole Locations and Dimensions - Flange-mount Large  
Cabinet

Overall Cabinet Dimensions:  
Height — 78"  
Width — 52"  
Depth — 21.375"

The cabinet must be mounted to a stable surface, such as concrete block, concrete, or brick. Alternatively, it can be attached to steel or aluminum walls, or robust wooden framing within a masonry opening, provided that these materials are strong enough to support up to 480 lbs.

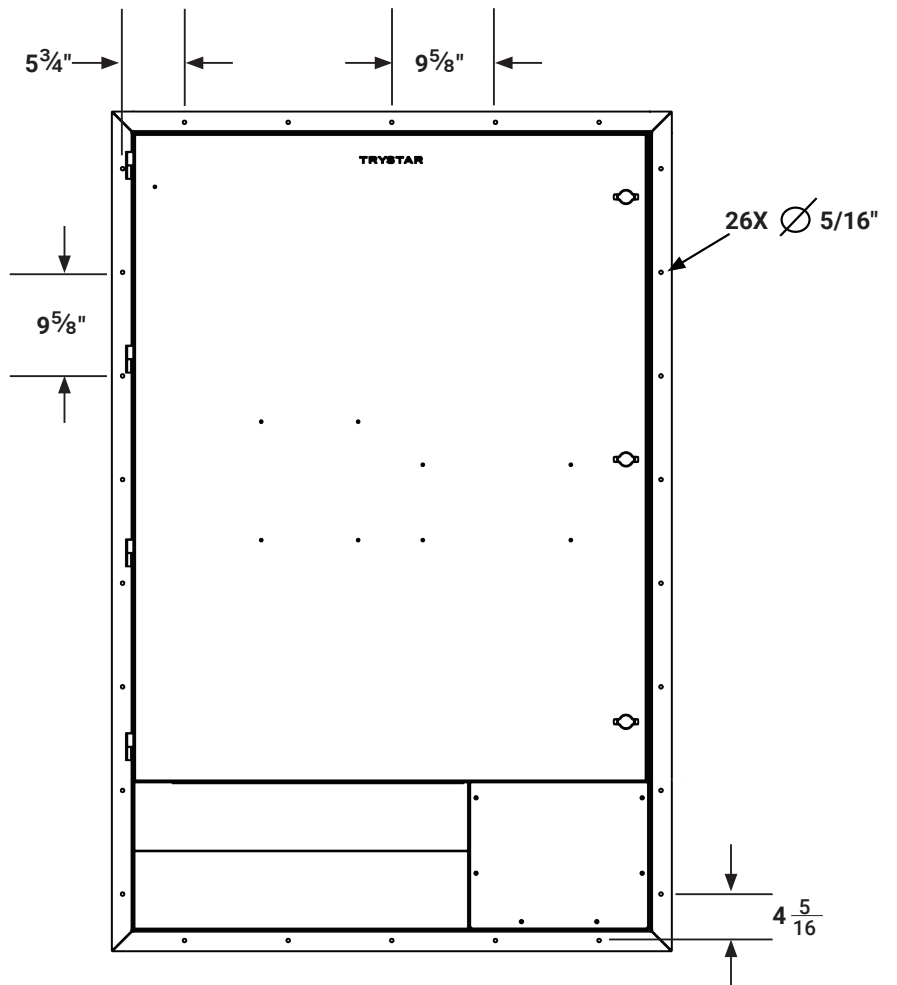

Image 5-22 –Large Flange-mount Cabinet

Mounting Hole Locations and Dimensions  
- Large Flange-mount Cabinet

Mounting Hole Locations and Dimensions - Flange-mount Medium Cabinet

Overall Cabinet Dimensions:  
Height — 70"  
Width — 44"  
Depth — 18.375"

The cabinet must be mounted to a stable surface, such as concrete block, concrete, or brick. Alternatively, it can be attached to steel or aluminum walls, or robust wooden framing within a masonry opening, provided that these materials are strong enough to support up to 320 lbs.

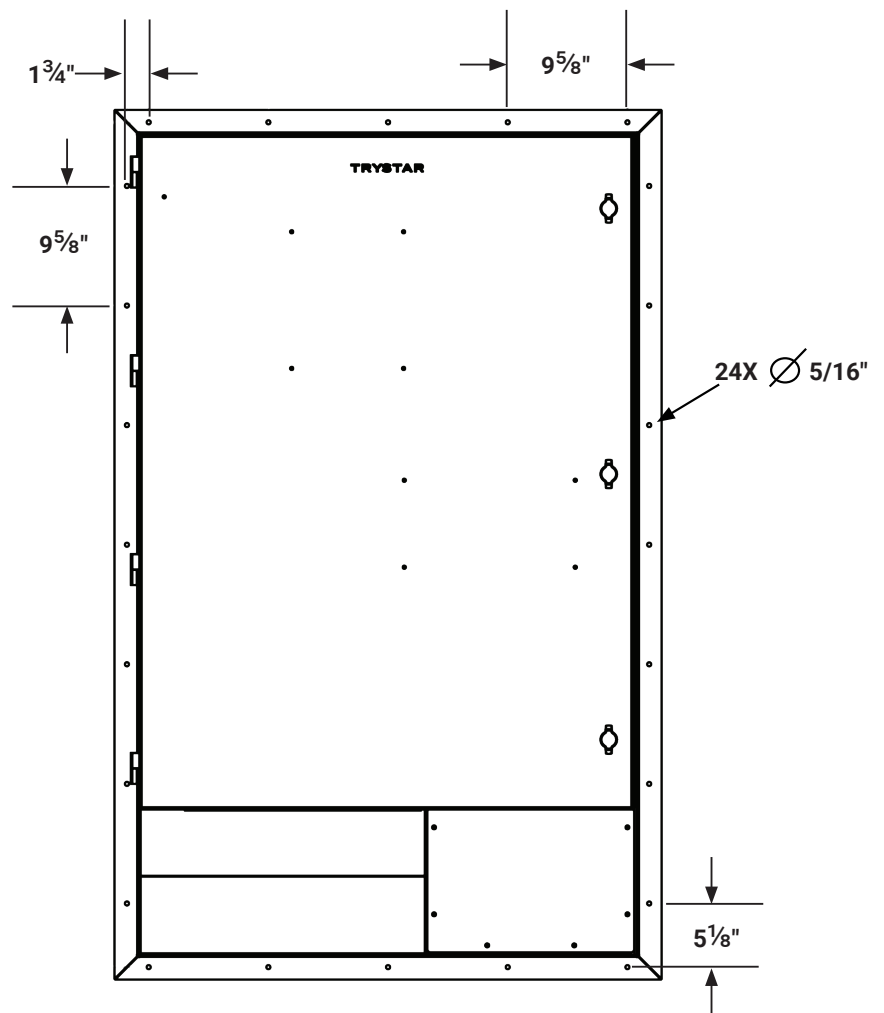

Image 5-23 –Medium Flange-mount Cabinet

Mounting Hole Locations and Dimensions  
- Small Flange-mount Cabinet

Mounting Hole Locations and Dimensions - Flange-mount Small  
Cabinet

Overall Cabinet Dimensions:  
Height — 64"  
Width — 34"  
Depth — 18.375"

The cabinet must be mounted to a stable surface, such as concrete block, concrete, or brick. Alternatively, it can be attached to steel or aluminum walls, or robust wooden framing within a masonry opening, provided that these materials are strong enough to support up to 160 lbs.

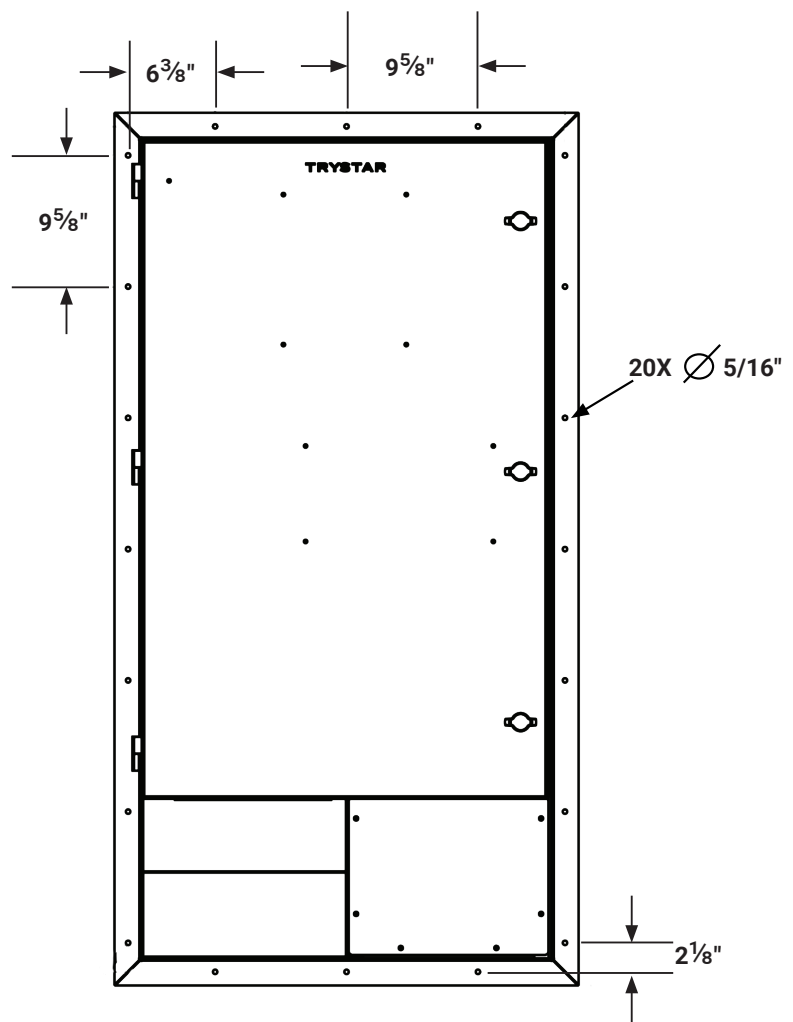

Image 5-24 –Small Flange-mount Cabinet

## 6—MOUNTING AND INSTALLATION - WALL-MOUNT CABINETS

### Installation Location

Choose an installation location that accommodates the Wall-mount, Wall-mount w/Leg Kit or Flange-mount design and adheres to all guidance and detailed conduit location drawings (shown in previous sections). The purpose of the drawings is to help installers choose a conduit entrance that accommodates tie-in point electrical infrastructure. Generally, position the cabinet near the main power feed or transfer switch (manual or automatic) if the transfer switch is not already integral to the Trystar enclosure.

### Mounting Configurations

There are several applications that are suitable for the Trystar GEN 3 Series Enclosures. It can be mounted to substantial brick, concrete, concrete block, and other masonry surfaces. It can also be mounted to steel or aluminum walls capable of supporting up to 480 lbs. plus cables. Similarly, there are a variety of installation styles, methods, and fasteners that can be used to simplify the process. This manual addresses some of the most common applications and methods of installation as well as hardware selections.

### Masonry Wall Installation

This installation calls for installing five 7/16" expansion anchor bolts into a masonry substrate for the upper and lower cabinet mounting tabs. Torque anchors to anchor manufacturer specifications. Secure enclosure with installation-appropriate washers, lock washers, and nuts.\*

To calculate the anchor bolt length, factor in cabinet mounting tab thickness (1/4" aluminum and 3/32" steel), substrate type and thickness, minimum embedment depth, and washer/nut clearances.

A typical length for a 7/16" anchor bolt in solid concrete would be 3 1/2". This accommodates a minimum embedment depth of 2 1/2" and an add-on length of 1" for mounting tab thickness, washers, and nuts. A total anchor length of 4" or 4 1/2" may be easier for practical clearance and ease of installation. You must also consider tensile and shear strength to determine the best hardware and embedment depth for your application. Follow the manufacturer's specifications on the hardware packaging.

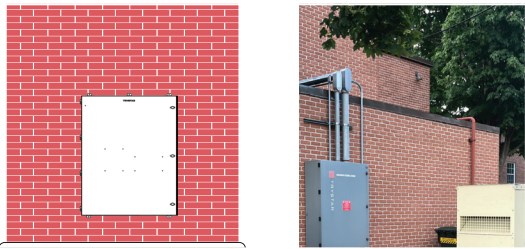
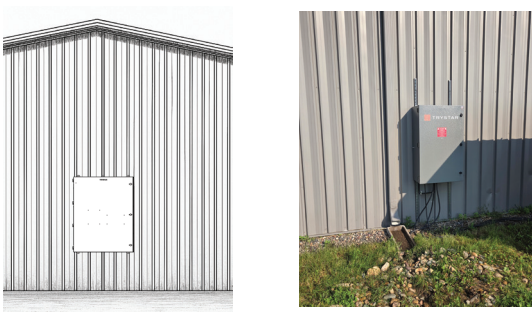

Image 6-1 –Installation Example

**Metal Wall Installation**



**Image 6-2 –Installation Example**

This installation calls for installing and fastening five 7/16” Hex bolts through the upper cabinet mounting tabs into a vertical metal substrate with corresponding washers, lock washers, and nuts. Torque to the hardware manufacturer’s specifications.

To calculate the Hex bolt length, factor in cabinet mounting tab thickness (1/4” aluminum and 3/32” steel), substrate type and thickness, and washer/nut clearances.

NOTE: You can substitute steel-base lock nuts (e.g., Nylock®) for the lock washers and Hex nuts.

**Drill/Cut Holes in Substrate**

**Drill/Cut Holes in Substrate as Necessary for Conduit Runs**

If the installation plan calls for cutting conduit holes into the substrate, Trystar recommends drilling those in advance of hanging the enclosure. Make sure the conduit holes are aligned with the intended conduit entrance panels on the GEN 3 Series cabinet.

**Punch/Drill Holes in Cabinets**

**Punch/Drill Out Holes In Cabinets for Conduit**

- Remove the access covers of the enclosure wiring compartment to enhance the interior view and to aid in routing conduit
- Size conduit holes according to cable rating
- Use a conduit hole-cutting device to accommodate the size of the conduit
- Vacuum up any metal shavings and clean up any lubricating oil (if used) from the cabinet

**Mark Hole Locations**

**Mark Mounting Hole Locations on Substrate**

Using a permanent marker or wax pencil, measure and mark the top two tab holes (furthest left and right) for the cabinet being installed. Use a mechanical or electronic level to confirm that the two marks are level with one another. Once aligned, mark the top center tab hole. Follow the same procedure as above to align, measure, and mark the two bottom installation hole locations. Ensure the distance between the top tab holes and bottom tab holes (centers) are the correct vertical distance from one another. (See Section: GEN 3 Series Line Drawings and Dimensions and Section: Mounting Holes and Locations).

**NOTE:**

*To maintain the integrity of the enclosure use proper conduit sealing methods as noted in Section (Installation Materials). Failure to do so could result in fire hazard or electrical shock that could lead to death or serious injury.*

*Cabinets should be mounted prior to making any conduit runs, wiring, and terminations.*

NOTE: Follow NEC Chapter 9 tables for conduit fill limits and NEC Table 310.15(B)(3)(a) for derating parallel conductors. Also, follow NEC 408.3 for the arrangement of wires in panel enclosures, which should be neat, supported and not under strain. Conduit should be sized to cable rating.

## Installing to Masonry Substrates

**NOTE:**

*Before locating/drilling GEN 3 Series Enclosure mounting holes into a substrate, check conduit locations and interior of cabinet to ensure the internal hardware aligns with the location and design of your installation plan.*

*If the rear conduit panel is to be used, cut the appropriate conduit holes in the panel and ensure access for running conduit prior to hanging the cabinet.*

**NOTE:** All fastener components should be suitable to the installation environment and properties of the aggregate-based substrate. Expansion anchor bolt types necessarily vary depending if the substrate is brick, concrete, or concrete block. If used, wedge and sleeve anchors should be tapped in flush with the aggregate surface and then tightened, torqued, and set before fastening the enclosure to the bolt heads.

### Masonry Installation for Installations Using Unistrut® on Masonry Substrates

- Note Hex bolt and anchor length notations (*See: Mounting Configurations and Details section*) and adhere to the anchor manufacturer's specifications on the hardware packaging for hole and embedment depth, etc.
- Choose five appropriately-rated 7/16" anchors suitable to the environment and installation needs
- Use a rotary hammer or hammer drill and the masonry bit to make a shallow "start mark" in the centers of each mounting tab hole previously marked in Section 6: Mark Mounting Hole Locations on Substrate
- Drill the five anchor holes to the correct depth for minimum embedment and to any other specifications noted on the anchor manufacturer's specifications as noted on the packaging
- Vacuum or blow out any concrete dust/debris from all five holes and off the top of the enclosure
- Following the anchor manufacturer instructions, tap the anchors into place until flush with the masonry surface and tighten/torque to specifications as necessary per anchor manufacturer instructions
- Remove any nut and/or washer from the anchor nuts
- Place a 7/16" washer over each of the anchor bolts
- Carefully lift the GEN 3 Series Enclosure and place it onto the five anchor bolts
- Place washer(s) and lock washers over the anchor bolts on the outside of the mounting tab\*
- Place Hex nuts onto the anchor bolts and tighten and torque to anchor manufacturer's specifications (on the hardware packaging)

\*You can substitute steel-based lock nuts (e.g., Nylock®) for the lock washers and Hex nuts.

## Installing to Metal Wall (Steel or Aluminum)

**NOTE:**

*All fastener components should be suitable to the installation environment.*

### Metal Wall Installation (Unistrut® Not Used)

- Ensure the Hex bolt selected will be long enough to pass through a flat washer, the mounting tab and metal wall. It also needs to have an adequate reveal on the wall's interior to accommodate a washer, lock washer and nut.
- Use a center punch to make a shallow "start mark" in the metal surface where the cabinet hole centers were previously located in ) (*Section 6: Mark Mounting Hole Locations on Substrate*)
- Using a high-speed or variable-speed drill (depending on substrate

hardness), and an appropriate drill bit, drill the five 7/16" holes for the mounting tabs

- Vacuum or wipe up any metal filings and lubricant (if any) from the installation area and the top of the enclosure
- Carefully lift the GEN 3 Series Enclosure and hold it in place over the bolt holes. Secure in place
- Place a 7/16" washer on each bolt and insert through each enclosure tab hole and through the wall
- With the GEN 3 Enclosure safely secured in place, put washers, lock washers, and Hex nuts on the bolts where they come through the wall and tighten to specifications

\*You can substitute steel-based lock nuts (e.g., Nylock®) for the lock washers and Hex nuts.

#### **Unistrut® and Unistrut Nut for Metal Wall Installation**

- Install Unistrut or other mounting hardware against the vertical metal substrate if desired. Refer to enclosure mounting tab locations shown in (Section: Mounting Hole Locations and Dimensions) and general dimensions section
- Insert strut nuts into each channel aligned with the cabinet mounting holes
- Insert 7/16" stud bolts with washers through the cabinet mounting holes and into the strut nuts
- Tighten each stud bolt securely and make provisions to prevent loosening over time

\*You can substitute steel-based lock nuts (e.g., Nylock®) for the lock washers and Hex nuts.

***To Complete Installation: Refer to Section 9 Finalizing Installation Procedures - All Cabinets - Pg. 49***

## **7—MOUNTING AND INSTALLATION - WALL-MOUNT CABINETS W/LEG KIT**

Note: Weatherproof caulk is recommended between the leg kit and the upper cabinet. Caulk should also be used between the enclosure bottom and concrete pad or other base substrate to prevent the intrusion of water, debris, and pests. All wall penetrations should be sealed to specifications or to the authority having jurisdiction

### **Installation Location**

Choose an installation location that accommodates the Wall-mount, Wall-mount w/Leg Kit, or Flange-mount design and adheres to all guidance and detailed conduit location drawings (shown in previous sections). The purpose of the drawings is to help installers choose a conduit entrance that accommodates tie-in point electrical infrastructure. Generally, position the cabinet near the main power feed or transfer switch (manual or automatic) if the transfer switch is not already integral to the Trystar enclosure.

## Mounting Configurations

There are several applications that are suitable for the Trystar GEN 3 Series Enclosures. It can be mounted to substantial brick, concrete, concrete block, and other masonry surfaces. It can also be mounted to steel or aluminum walls capable of supporting up to 480 lbs. plus cables. Similarly, there are a variety of installation styles, methods, and fasteners that can be used to simplify the process. This manual addresses some of the most common applications and methods of installation as well as hardware selections.

### Concrete Pad/Island Installation



**Image 7-1 –Installation Example**

This installation would call for inserting four 5/8” expansion anchors into the concrete pad in alignment with the leg kit mounting holes. Expand and torque the anchors to anchor manufacturer specifications. Secure leg kit to anchor bolts with washers, lock washers and nuts appropriate to the installation. You can secure the leg kit first and subsequently assemble the upper cabinet to the leg kit.

### Concrete Pad/Masonry Wall Installation

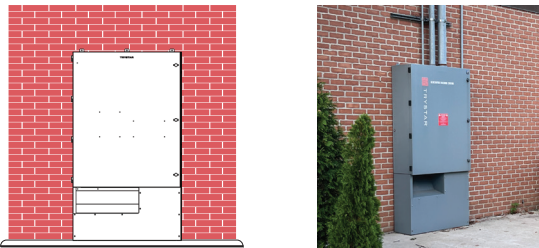

**Image 7-2 –Installation Example**

Anchor the leg kit to the concrete pad with 5/8” expansion anchors in alignment with the leg kit mounting holes. Expand and torque the anchors to anchor manufacturer specifications. Secure leg kit to anchor bolts with washers, lock washers, and nuts appropriate to the installation. Fasten the upper cabinet to the leg kit. Install three 7/16” concrete screws through the upper cabinet mounting tabs directly into a masonry substrate. The upper cabinet can also be fastened to strut channel that is anchored to the masonry wall with concrete screws. (NOTE: It may be easier to install the strut channel framework before fastening the upper cabinet to the leg kit.) Fasten the cabinet to the strut channel with strut fasteners suitable for the installation.

### Concrete Pad/Metal Wall Installation

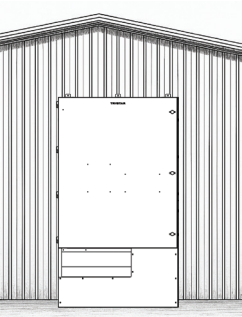

**Image 7-3 –Installation Example**

This installation calls for installing four 5/8” expansion anchors into the concrete pad in alignment with the leg kit mounting holes. Expand and torque the anchors to anchor manufacturer specifications. Secure leg kit to anchor bolts with washers, lock washers, and nuts appropriate to the installation. Fasten the upper cabinet to the leg kit. Install and fasten three 7/16” Hex bolts through the upper cabinet mounting tabs into a metal wall with corresponding washers, lock washers and nuts.\* Alternatively, the upper cabinet can be secured to a strut channel framework with strut channel and fasteners appropriate to the installation environment.

\*You can substitute steel-based lock nuts (e.g., Nylock®) for the lock washers and Hex nuts.

When mounting an enclosure to both the concrete pad and the vertical substrate, you may need to account for the slope of the pad as it applies to the overall length of the fasteners used for the enclosure mounting tabs and wall.

**Drill/Cut Holes in Substrate****NOTE:**

*Weatherproof caulk is recommended between the leg kit and the upper cabinet. Caulk should also be used between the enclosure bottom and concrete pad or other base substrate to prevent the intrusion of water, debris, and pests. All wall penetrations should be sealed to specifications or to the authority having jurisdiction.*

**NOTE:**

*The wall mount with leg kit enclosure is typically installed on a fully-cured concrete pad. In most cases, the pad has not been pre-prepared with cast-in-place anchor bolts, i.e., existing mounting bolts.*

*Before installing the GEN 3 Enclosure to a concrete base, check the slope of the base using a bubble level or similar tool. The base may be sloped away (down) from the vertical substrate to facilitate drainage. It is advisable to shim and plumb the cabinet before final installation to accommodate the slope, facilitate connection of the upper mounting tabs, and relieve any undue stress the slope would impose on the upper cabinet mounting tabs and substrate.*

**NOTE:**

*To maintain the integrity of the enclosure use proper conduit sealing methods as noted in (Section 3: Installation). Failure to do so could result in fire hazard or electrical shock that could lead to death or serious injury.*

*Cabinets should be mounted prior to making any conduit runs, wiring, and terminations.*

**Drill/Cut Holes in Substrate as Necessary for Conduit Runs**

If the installation plan calls for cutting conduit holes into the substrate, Trystar recommends drilling those in advance of hanging the enclosure. Make sure the conduit holes are aligned with the intended conduit entrance panels on the GEN 3 Series cabinet.

**Punch/Drill Out Holes In Cabinets for Conduit**

- Remove the access covers of the enclosure wiring compartment to enhance the interior view and to aid in routing conduit
- Size conduit holes according to cable rating
- Use a conduit hole-cutting device to accommodate the size of the conduit
- Vacuum up any metal shavings and clean up any lubricating oil (if used) from the cabinet

**Fastening Leg Kit to Concrete Island Pad**

- Choose four 5/8" masonry expansion anchors suitable to the installation requirements
- Using the leg kit pedestal as a template, place it in the desired location on the pad
- Using a bubble level (or similar) plumb the leg kit while in position using shims
- Take note of the shim positions and placement for repositioning in a later step
- Use a permanent marker, pencil, or wax pencil to mark the centers of the four mounting holes. Use the masonry drill and bit to make a shallow "start mark" in the center of each hole
- Set the leg kit pedestal and shims aside
- Using an appropriate drill bit and drill (See Section 2.01 Installation Tools), drill the holes for the four 5/8" anchor holes to the diameter and depth indicated by the anchor manufacturer's specifications on the hardware packaging
- Vacuum or blow out any concrete dust/debris from the four holes
- Install anchors per manufacturer instructions (tighten and expand)
- Retrieve the shims and place them in the positions previously determined to re-level the leg kit or re-plumb leg kit with the level as necessary
- We advise using caulk around the perimeter of the leg kit where it meets the concrete pad. Review Section 6.18 (Sealing Leg Kit to Concrete Pad) before proceeding
- Retrieve and settle the leg kit over the pad (and any shims if used) and align the leg kit mounting holes with the anchor bolts
- Place washers, lock washers, and Hex nuts over the anchor bolts
- Tighten and torque the nuts to the expansion anchor manufacturer's specifications

- Use structural filler to serve as a more permanent shim across the front and down the sides (if necessary) of the leg kit to provide more even, long-term leveling support
- Caulk the perimeter of the leg kit where it meets the concrete pad once the structural filler is cured
- Follow the instructions in Section 6.14 (Assemble Upper Cabinet to Previously-Installed Leg Kit) to complete the enclosure assembly

NOTE: Trystar recommends appropriately-rated (significant tensile/shear strength) stainless steel, galvanized or zinc-plated expansion anchor bolts. Follow anchor torque settings on hardware packaging to avoid pullout.

### **Assemble Upper Cabinet**

#### **Assemble Upper Cabinet to Previously-Installed Leg Kit**

- The hardware for this step is provided in the GEN 3 Series packaging. It includes (8) 3/8" and (2) 1/4" stainless-steel Hex machine bolts and corresponding hardware including washers (20), lock washers (10), and nuts (10). The cabinet top has knockout holes for each bolt. The bottom (leg kit) portion is pre-drilled.
- Knock out the 3/8" and 1/4" slugs on the upper cabinet base
- Run a continuous bead of neutral-cure silicone or other suitable weatherproof sealant along the top of previously-installed leg kit (close to the bolt holes and around the perimeter)
- Lift, position and align the upper cabinet bolt holes with those in the leg kit
- Gently lower the upper cabinet onto the leg kit
- Place the provided 3/8" bolts with one washer each through the upper cabinet holes and through the holes in the leg kit. Place washers on the opposite side of the bolts followed by lock washers and nuts
- Firmly hand tighten the 3/8" nuts before the caulk skins over (usually within 5–10 minutes)
- Repeat the process above for the 1/4" bolt assemblies
- Torque all nuts to specifications in Section 4.01 (Torque Values for Machine Bolts)
- Note if there is any substantial gap between the enclosure's top mounting tabs and the vertical wall
- Measure any gap between each mounting tab and the wall and keep the information handy as you will need it in a later step

### **Calculating Screw/Bolt Lengths**

#### **Calculating Concrete Screw, Hex Bolt, or Stud Bolt Length for Enclosure Wall Mount Tabs**

The next two scenarios are installations with a concrete pad and an adjacent wall. The wall could be masonry or metal. Regardless, depending on where you sited the leg kit on the concrete pad, there may be a gap between the upper mounting tabs of the enclosure and the wall surface (or strut channel nut). Accordingly, this gap can bear on the length of the concrete screw (masonry wall), Hex bolt (metal

wall), or stud bolt (Unistrut®) you will choose.

### Filling Any Gaps Between Upper Mounting Tabs and Wall

Refer to pg. 19: (Assemble Upper Cabinet to Previously-Installed Leg Kit). The distances between each of the three mounting tabs and the vertical wall were considered and measured after assembly.

Plan to use washers suitable for the environment to reasonably fill any gap behind the mounting tab and wall or strut channel before fastening the enclosure to either. Note how many washers are required for each hole gap. If the gap requires more than one washer, tape the washers together to form a unit before inserting the concrete screw, Hex bolt, or stud bolt through a washer, the mounting tab, and subsequently through the set of washers.

Choose a 7/16" concrete screw (e.g., Tapcon®) accordingly to provide enough reveal for proper embedment into the masonry. Also, factor in masonry substrate depth/type and any tension or shear forces, or potential for accidental impacts, given the location. The measurements you took between tabs and wall will tell you if your concrete screw can bridge the gap and provide enough reveal for a secure installation into the masonry substrate. Follow concrete screw installation instructions and specifications shown on the packaging.

The measurement taken on pg. 19: (Assemble Upper Cabinet to Previously-Installed Leg Kit) also informs the length of the Hex bolt or stud bolt you will choose when fastening the enclosure to a metal wall or to strut channel. Bolt lengths are determined by the gap, plus tab width (1/4" aluminum and 3/32" steel), plus any washers and the location of the strut nut or the width of the metal wall.

## Fastening Upper Cabinet

### Fastening Upper Cabinet Directly to Masonry Wall

Given any gap you may have to take up with washers, ensure your concrete screws are the correct length as noted on previous page: (*Calculating Concrete Screw, Hex Bolt, or Stud Bolt Length for Enclosure Wall Mount Tabs*)

- Using the fully assembled enclosure as a template, use a permanent marker, pencil, or wax pencil to mark the center of the three mounting tab holes on top. Use the masonry drill and bit to make a shallow "start mark" in the masonry surface
- Drill a pilot hole for each of the three 7/16" mounting tab holes following the concrete screw manufacturer's instructions as shown on the packaging (typically 5/32" for a 7/16" concrete screw)
- Collect the appropriate amount of washers for each gap — if any — and tape them together into units for each respective tab
- Holding the washer set behind the mounting tab, and in front of the hole in the wall, insert the concrete screw through a washer, the mounting tab, any washer set, and into the pilot hole in the masonry substrate. Concrete screws are self-tapping.
- Fasten upper cabinet tabs to masonry wall

### Fastening Upper Cabinet to Strut Channel Frame On Masonry

Install strut channel to the masonry wall if desired. Rather than using the fully assembled enclosure to align the strut channel with the tab hole locations, it may be easier to install the strut channel first. Refer to

#### NOTE:

*Weatherproof caulk is recommended between the leg kit and the upper cabinet. Caulk should also be used between the enclosure bottom and concrete pad or other base substrate to prevent the intrusion of water, debris, and pests. All wall penetrations should be sealed to specifications or to the authority having jurisdiction.*

enclosure mounting tab locations shown in Sections: (*Mounting Hole Locations and Dimensions*) and general dimensions in: (*GEN 3 Series Line Drawings and Dimensions*).

- Use a permanent marker, pencil, or wax pencil to mark strut channel fastening locations
- Ensure the upper cabinet tab holes of the enclosure will align with the strut channel once installed
- Drill pilot holes in the masonry following the concrete screw manufacturer's instructions as shown on the packaging
- Fasten strut channel to wall with concrete screws
- Given any gap you may have to take up with washers, ensure your stud bolts are the correct length as noted in Section 6.15 (*Calculating Concrete Screw, Hex Bolt, or Stud Bolt Length for Enclosure Wall Mount Tabs*)
- Collect the appropriate amount of washers for each gap — if any — and tape them together into units for each respective tab as necessary
- Insert strut nuts into each channel aligned with the cabinet mounting holes
- Holding a washer set (if needed) behind each individually-measured gap behind the enclosure mounting tab, insert the 7/16" stud bolts/threaded studs through a washer, the mounting tab, the washer set or spacer, and into the strut nut
- Tighten each stud bolt securely and make provisions to prevent loosening over time

## **Sealing Leg Kit to Concrete Pad**

### **Sealing Leg Kit to Concrete Pad**

Trystar recommends using caulk to prevent the possible intrusion of moisture, pests, and other materials between the leg kit and the concrete pad. It should be applied after any structural filler — used to serve as a more permanent shim across the front and sides — has cured. Apply caulk that's approved for the installation location and/or by the authority having jurisdiction around the perimeter of the leg kit after installation.

If clearance behind the assembled enclosure will be too tight to reach (in a vertical wall and concrete pad installation), you can run a slightly oversized bead of sealant on the back edge of the leg kit before setting it into place. Make sure to keep any shims used for the leveling process away from the caulk line to ensure good adhesion to the concrete.

As noted earlier, structural filler serves as a more permanent shim across the front and down the sides (if necessary) of the leg kit to provide more even, long-term leveling support.

### **Attach Upper Cabinet to Metal Wall (Steel or Aluminum)**

NOTE: Fasten the leg kit to the concrete pad following the steps in Section: (*Fastening Leg Kit to Concrete Pad*)

**NOTE:**

All fastener components should be suitable to the installation environment. A common installation for the GEN 3 Series Enclosure is on a concrete pad adjacent to a metal wall such as the exterior of a metal building. Many of the same installation steps in previous sections apply.

- Install Unistrut or other mounting hardware against the metal wall if desired. Reference enclosure mounting tab locations shown in Sections: *(Mounting Hole Locations and Dimensions)* and dimensions *(GEN 3 Series Line Drawings and Dimensions)*
- Follow the appropriate steps in Section: *(Assemble Upper Cabinet to Leg Kit)* to fasten the upper cabinet to the leg kit if not already completed
- Note if there is any substantial gap between the enclosure's top mounting tabs and the vertical wall or Unistrut®
- Measure any gap between each mounting tab and the wall and keep the information handy as you will need it in a later step

**Filling Any Gaps Between Upper Mounting Tabs and Wall**

In Section: *(Assemble Upper Cabinet to Previously-Installed Leg Kit)*, the distances between each of the three mounting tabs and the vertical wall were considered and measured.

Plan to use washers suitable for the environment to reasonably fill any gap behind the mounting tab and wall or behind the mounting tab and installed strut channel nut before fastening the enclosure to either. Note how many washers are required for each hole gap. If the gap requires more than one washer, tape the washers together to form a unit before final assembly.

The measurement taken in Section 6: *(Assemble Upper Cabinet to Previously-Installed Leg Kit)* informs the length of the Hex bolt or stud bolt you will choose when fastening the enclosure to a metal wall or to strut channel. Bolt lengths are determined by the gap, plus tab width *(1/4" aluminum and 3/32" steel)*, plus any washers and the location of the strut nut or the width of the metal wall. There must be enough reveal on the other side of any washers to screw into a strut nut for a secure installation. Similarly, for the Hex bolt, there must be enough reveal on the interior of the wall for a washer, lock nut, and Hex nut.

**Metal Wall Installation****Metal Wall Installation (Strut Channel Not Used)**

If using a Hex bolt through a solid metal vertical wall, make sure it is long enough to provide an adequate reveal despite having to pass through the mounting tab and any washer set or spacers inside the tab, in addition to the washer, lock washer, and nut required on the interior of the wall.

- Using the fully assembled enclosure as a template, use a permanent marker or pencil to mark the center of the three mounting tab holes on the steel/aluminum wall. Use a center punch to make a shallow "start mark" in the metal surface
- Using an appropriate drill bit and drill *(See Section: Installation Tools)*, drill the holes for the three 7/16" mounting tabs at the top through the metal wall
- Vacuum or wipe up any metal filings from the installation area and the top of the enclosure
- Collect the appropriate amount of washers for each gap — if any — and tape them together into units for each respective tab as necessary

- Holding the washer set behind the mounting tab, and in front of the hole in the wall, place a washer on the Hex bolt and insert it through the mounting tab, through the washer set or spacer, and through the hole in the substrate
- Place a washer, lock washer and Hex nut on the bolt where it comes through the wall and tighten securely

**Metal Wall Installation (Strut Channel Used)**

Collect the appropriate amount of washers for each gap — if any — and tape them together into units for each respective tab as necessary

- Holding a washer set behind each individually-measured gap behind the enclosure mounting tab, insert the strut stud bolt/ threaded stud through a washer, the mounting tab, the washer set or spacer, and into the strut nut
- Tighten each stud bolt securely

**NOTE:**

*Other mounting methods may be applicable but require a professional engineering solution and are outside the scope of this GEN 3 Installation Manual.*

***To Complete Installation: Refer to Section 9 Finalizing Installation Procedures - All Cabinets - Pg. 49***

***Mounting and Installation - flange-mount cabinets***

**Installation Location**

Choose an installation location that accommodates the Wall-mount, Wall-mount w/Leg Kit, or Flange-mount design and adheres to all guidance and detailed conduit location drawings (shown in previous sections). The purpose of the drawings is to help installers choose a conduit entrance that accommodates tie-in point electrical infrastructure. Generally, position the cabinet near the main power feed or transfer switch (manual or automatic) if the transfer switch is not already integral to the Trystar enclosure.

**Mounting Configurations**

There are several applications that are suitable for the Trystar GEN 3 Flange Mount Enclosure. It can be mounted to substantial brick, concrete, concrete block, and other masonry surfaces. It can also be mounted to steel or aluminum walls capable of supporting up to 480 lbs. plus cables. Similarly, there are a variety of installation styles, methods, and fasteners that can be used to simplify the process. This manual addresses some of the most common applications and methods of installation as well as hardware selections.

**Masonry Wall Installation**

Image 8-1 –Installation Example

In this scenario, the flange mount cabinet would be inset into an opening in the masonry substrate. The flange would be fastened to the masonry surround using multiple (depending on enclosure size) 5/16" installation-appropriate concrete screws.

To calculate the concrete screw depth, factor in cabinet mounting tab thickness (1/4" aluminum and 3/32" steel) substrate type and thickness and minimum embedment depth.

It is also common to frame out a rough masonry opening with wood framing members which will accept fasteners like lag bolts or structural screws. In this scenario it would be appropriate to use caulk or a combination of flashing and caulk to seal the opening from outside elements that could denigrate the substructure and affect the safe and reliable operation of the Trystar GEN 3 Enclosure.

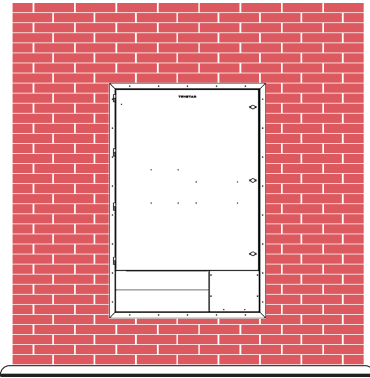
**Metal Wall Installation**

Image 8-2 –Installation Example

This installation calls for installing and fastening multiple (depending on enclosure size) 5/16" Hex bolts through the flange into a metal wall with corresponding washers, lock washers, and nuts. To calculate the Hex bolt length, factor in cabinet mounting tab thickness (1/4" aluminum and 3/32" steel), substrate type and thickness, appropriate shear and tensile strength (for the installation), and washer/nut clearances.\*

You can substitute steel-base lock nuts (e.g., Nylock®) for the lock washers and Hex nuts.

**NOTE:**

*To maintain the integrity of the enclosure use proper conduit sealing methods as noted in (Section 3: Installation). Failure to do so could result in fire hazard or electrical shock that could lead to death or serious injury.*

*Cabinets should be mounted prior to making any conduit runs, wiring, and terminations.*

**Drill/Cut Holes in Substrate as Necessary for Conduit Runs**

Since the flange mount enclosure is inset, it may offer easy access to conduit panels from the interior. Yet, If the installation plan calls for drilling/cutting any conduit holes into the substrate, Trystar recommends drilling/cutting those in advance of hanging the enclosure. Make sure the conduit holes are aligned with the intended conduit entrance panels on the GEN 3 Series cabinet.

**Punch/Drill Out Holes In Cabinets for Conduit**

- Remove the access covers of the enclosure wiring compartment to enhance the interior view and to aid in routing conduit
- Size conduit holes according to cable rating
- Use a conduit hole-cutting device to accommodate the size of the conduit
- Vacuum up any metal shavings and clean up any lubricating oil (if used) from the cabinet

Follow NEC Chapter 9 tables for conduit fill limits and NEC Table 310.15(B)(3)(a) for derating parallel conductors. Also, follow NEC 408.3

for the arrangement of wires in panel enclosures, which should be neat, supported and not under strain. Conduit should be sized to cable rating.

### **Installing to Masonry Substrates**

**NOTE:**

*NOTE: All fastener components should be suitable to the installation environment and properties of the aggregate-based substrate.*

#### **Masonry Installation — Concrete Screws**

- Ensure the concrete screw selected will be long enough to pass through the exterior washer, the flange (1/4" aluminum and 3/32" steel), and into the masonry wall with enough embedment depth to provide a secure installation. See manufacturer specifications and instructions on the concrete screw packaging.
- Referencing Section 4 (Line Drawings and Dimensions), ensure the GEN 3 enclosure fits into the masonry rough opening while allowing enough flange landing space for the flange to be securely fastened
- Place a heavy bead of exterior-grade caulk on the flange interior that offers good adhesion to metal and masonry and serves as a barrier to moisture intrusion
- Carefully lift and place the GEN 3 Flange Mount Enclosure into the rough opening of the metal wall. Shim as necessary to ensure it is level. Secure the enclosure in the opening for installer safety.
- Mark the center location in each flange hole with a permanent marker, pencil or wax pencil
- Using an appropriate drill bit and drill (See Section 2.01 Installation Tools) drill a pilot hole for each of the flange mounting holes following the concrete screw manufacturer's instructions as shown on the packaging (typically 5/32" for a 7/16" concrete screw)
- Vacuum or blow out any concrete/brick dust/debris from all holes and the enclosure
- Drive the concrete screws through a flat washer, the flange and into the masonry wall
- Apply exterior-grade caulk to the perimeter of the flange where it meets the masonry substrate. Choose a caulk that offers good adhesion to both metal and masonry surfaces, is paintable (if desired), and serves as a barrier to moisture intrusion

#### **Masonry Installation — Wood-Framed Opening (Structural Screws or Lag Bolts)**

It is also common to frame out a rough masonry opening with wood framing members which will accept fasteners like lag bolts or structural screws. Many of the same steps for installing into masonry walls apply as follows:

- Frame out the masonry opening with wood framing members to accommodate the cabinet dimensions while allowing an adequate flange landing surface (See Sections 5.01— 5.03 GEN 3 Series Line Drawings and Dimensions and Sections 6.06 — 6.08 Mounting Holes and Locations)

- Lag bolts or structural screws must fully embed into solid wood for holding strength. For optimal holding and safety, use 2x6 framing members (1.5" thick). It's preferable to double up the framing to get 3" thickness and stronger grab
- Choose 5/16" lag bolts or structural screws that allow a 2" embedment and enough extra length to accommodate a flat washer and the flange width (1/4" for aluminum and 3/32" for steel)
- Place a heavy bead of exterior-grade caulk on the flange interior that offers good adhesion to both metal and wood and serves as a barrier to moisture intrusion
- Carefully lift and place the GEN 3 Flange Mount Enclosure into the rough opening and shim as necessary to ensure it is level and stable. Secure the enclosure in the opening for installer safety.
- Mark the hole center locations in each flange mounting hole with a permanent marker, pencil, or wax pencil
- If driving lag bolts into SPF (spruce, pine, fir), pre-drill 3/16" pilot holes. If driving lag bolts into hard wood, pre-drill 7/32" pilot holes. Structural screws do not require pre-drilling
- Place a washer on each lag bolt or structural screw and fasten the flange to the framing members
- Apply exterior-grade caulk to the perimeter of the flange where it meets the flange landing material. Choose a caulk that offers good adhesion to both substrates, is paintable (if desired), and serves as a barrier to moisture intrusion

In this scenario it may be appropriate to use caulk or a combination of flashing and caulk to seal the opening from outside elements that could otherwise degrade the framing material and affect the safe and reliable operation of the Trystar GEN 3 Enclosure.

### Installing to Metal Walls (Steel or Aluminum)

#### Metal Installation - Hex Bolts

Ensure the Hex bolt selected will be long enough to pass through the exterior washer, the mounting tab (1/4" aluminum and 3/32" steel), and metal wall. It also needs to have an adequate reveal on the wall's interior to accommodate a washer, lock washer, and nut\*

- Referring to Sections 4 (Line Drawings and Dimensions) and Section 5 (Mounting Holes and Locations), cut out an opening in the metal wall that accommodates the cabinet dimensions while allowing an adequate flange landing space
- Carefully lift and place the GEN 3 Flange Mount Enclosure into the rough opening of the metal wall. Shim as necessary to ensure it is level. Secure the enclosure in the opening for installer safety.
- Mark the center location of each flange hole with a permanent marker, pencil, or wax pencil
- Use a center punch to make a shallow "start mark" in the metal surface where the cabinet hole centers were marked

#### NOTE:

*NOTE: All fastener components should be suitable to the installation environment and properties of the aggregate-based substrate.*

- Using a high-speed or variable-speed drill (depending on substrate hardness), and an appropriate drill bit, (See Section 2.01 Installation Tools) drill the 5/16" holes for the mounting flange holes
- Vacuum or wipe up any metal filings and lubricant (if used) from the installation area and off the enclosure
- Place a washer on each 5/16" Hex bolt and insert through each flange hole and through the wall
- With the GEN 3 Enclosure safely secured in the opening, place a washer, lock washer, and Hex nut on the bolt where it comes through the wall and tighten to specifications noted by the manufacturer of the hardware fasteners
- Properly seal any penetrations in the enclosure and wall

\*You can substitute steel-based lock nuts (e.g., Nylock®) for the lock washers and Hex nuts.

**NOTE:**

*Other mounting methods may be applicable but require a professional engineering solution and are outside the scope of this GEN 3 Installation Manual.*

## **8—FINALIZING INSTALLATION PROCEDURE - ALL CABINETS**

### **Disconnect Main Power**

Shut off the primary voltage using approved lockout/tagout procedures

Lockout/Tagout (LOTO) procedures are critical safety protocols designed to prevent the unexpected energization or release of hazardous energy during installation, maintenance, or servicing activities. Adhering to comprehensive LOTO procedures is essential to ensure worker safety when de-energizing utility power to install and connect a commercial enclosure for a backup generator. For comprehensive guidelines and regulatory requirements, refer to OSHA's standard on the Control of Hazardous Energy (Lockout/Tagout), found in 29 CFR 1910.147 or latest version. Follow ALL appropriate safety standards and practices, as it's your responsibility to ensure there is no danger to health, wellbeing, or property.

### **Route Conduits**

- Remove the access covers of the wiring compartment to enhance interior view and to aid in routing conduit
- If not done in the previous section, punch or drill out conduit holes according to cable rating
- Vacuum any metal shavings or other debris from the cabinet and wipe up any lubricant
- Route conduits into enclosure from the main electric panel (if the transfer switch is integral to the enclosure) or from the transfer switch if it is external to the enclosure

**Pull Line Wires**

- To maintain the integrity of the enclosure use proper conduit sealing methods and hardware as noted in Section 3
- Using a fish tape or pulling rope, pull properly-rated conductors from the main utility connection or designated tie-in location to the enclosure
- If using a transfer switch that's external to the enclosure, pull main utility wires directly to the transfer switch and thereon to the building's electrical system

**Connect Lines to Terminals**

Connect the line wires to the appropriately labeled terminals and torque them appropriately according to the conductor size for parallel conductors per NEC specifications and authority having jurisdiction

**Confirm Torque Values**

**Confirm Torque Values for Bolts and Lugs and Check Other Connectors for Tightness**

- Torque 2S-350 lugs to 31 ft-lbs. and 2S-600 lugs to 42 ft-lbs. See the chart in section 3. Check all site-connected terminations for proper torque using the torque values noted above or to manufacturer specifications
- Check all other terminations for loose connections and proper torque values. Loose connections cause heat and potentially a hazardous situation.

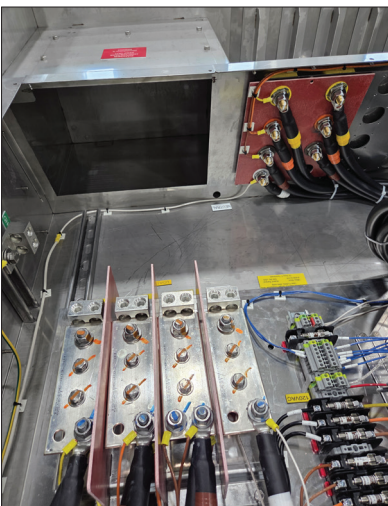

**Image 9-1 –Connect Lines to Terminals**

**Bonding of the Equipment Grounded Conductor**

Ground the cabinet in accordance with NEC and NFPA electrical codes and authority having jurisdiction

Please note if the grounding (green) conductor and the grounded (neutral) conductor are bonded together in the docking station. The generator should not be bonded unless otherwise required by authorities having jurisdiction.

If the grounding (green) conductor and the grounded (neutral) conductor are bonded together in the generator, the docking station should not be bonded, unless otherwise required by authorities having jurisdiction.

**NEVER BOND THE GROUND AND NEUTRAL IN BOTH THE DOCKING STATION AND THE GENERATOR.**

**Confirm Minimum Cable/Energized Part Clearance**

Ensure a minimum clearance of 1" between enclosure and any uninsulated energized parts as well as uninsulated phase-to-phase conductors throughout the installation process

**Replace Covers, Barriers and Access Panels**

Close and secure all access panels, barriers and covers removed for

**NOTE:**

*Enclosures must be properly grounded according to NEC Article 250 and NFPA 110 for emergency power supply systems. Serious injury including burns and death can occur when equipment is not properly grounded. All installation practices must comply with all applicable national and/or local electrical and building codes and be performed by qualified personnel only.*

visibility and work

### Energize

- Energize the unit
- Go to next section (**Phase Monitor Installation**) and follow installation instructions for the phase monitor if applicable

The setup of the enclosure phase rotation monitor will require the use of a hand-held phase rotation meter. The test will determine the phase rotation of the building's electrical system. The phase rotation monitor provided in the GEN 3 Series Enclosure is factory configured to indicate (light up) when a clockwise direction is sensed.

### Phase Monitor Installation

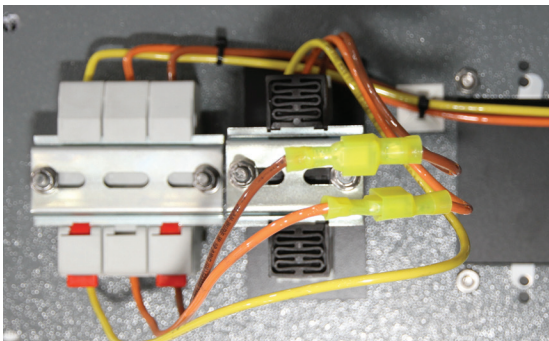
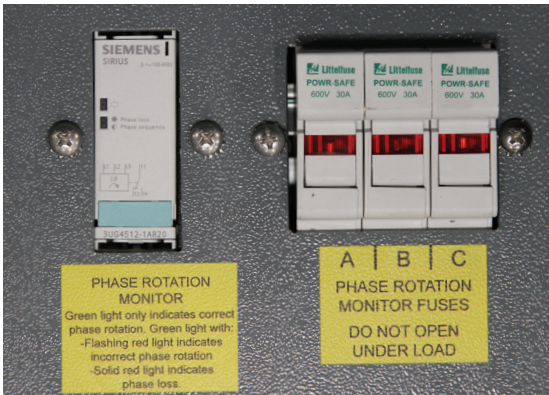

Image 9-2 and 9-3 –Phase Monitor

- Test the existing load at the point where the enclosure unit will be tied in
- If the test concludes that the facility has a clockwise rotation, sign and date the Phase Rotation Monitor Installation Procedure Form (Section 12) associated with this manual.
- Make a copy of the Procedure Form and keep it with the enclosure documentation for further reference and use
- If the test concludes that the facility has a counter-clockwise rotation, then you will need to change the Trystar enclosure phase rotation monitor so that it will indicate (light up) when a counter-clockwise direction is sensed.
- Locate the phase colored wires that feed into the back of the phase rotation monitor. Follow these wires until you find a male/female connector set.
- Unplug the B phase male connector from the female connector, and the C phase male connector from the female connector. (Connectors could be on A and C or A and B phase on some units — follow the same procedure)
- Next Plug the A phase male connector into the B phase female connector, and the B phase male connector into the A phase female connect
- The GDS phase rotation monitor is now set up to indicate (light up) when a counter-clockwise direction is sensed.

#### NOTE:

Only qualified personnel should work with energized equipment. Follow NFPA 70 — the benchmark for safe electrical design, installation, and inspection — with respect to working with the phase monitor, the GEN 3 Series Enclosure and related electrical infrastructure. Wear appropriate PPE.

## 9—ANNUAL MAINTENANCE

NOTE: Shut off the primary voltage using approved lockout/tagout procedures  
To maximize the safe and effective operation of the Trystar GEN 3 Enclosure, it is important to perform an annual maintenance check.

### Visual Inspection of Enclosure Exterior

#### Visible Inspection of Enclosure Exterior

- Shut off the primary voltage using approved lockout/tagout procedures
- Ensure the Trystar GEN 3 Enclosure is firmly attached to its base or building
- Review conduit connections for signs of leakage
- Inspect the cabinet for rust, corrosion, or damage that could lead to damage or corrosion that must be repaired
- Ensure all exterior badges and labels are clean, legible and secure
- Ensure cabinet door hinges are secure and lubricated
- Ensure door latches turn freely
- Ensure the cabinet door is firmly closed when latched and that the gasket makes good contact at all points
- Ensure the cabinet is dry and free of dirt, grit and other debris
- Ensure bottom rake panel opens and closes without binding and that the latches are tight when fastened

### Visual Inspection of Enclosure Interior

#### Visible Inspection of Enclosure Interior

- Ensure the cabinet is dry and free of dirt, grit, and other debris
- Ensure cabinet seals and gaskets remain pliable and show no visible signs of cracks
- Ensure that all load terminals are securely fastened and that any nuts and bolts are set to the required torque
- Ensure the cabinet interior exhibits no signs of rust or corrosion
- Ensure electrical connections are intact with no signs of corrosion or cracking
- Ensure access panels are secure and tight
- Review all safety labels and ensure they are present and legible — replace as needed
- Look for signs of overheating such as physical discoloration and burned insulation and make repairs as necessary to ensure safety and correct operation
- A thermal imaging inspection is recommended

**NOTE:**

*If Powering Down is not an option, follow all safety guidelines.*

## 10—TECHNICAL SUPPORT

Trystar's primary goal is to ensure its customers are delighted with the performance and durability of its products. Please call us with any questions about the safety, operation, or performance of your wall-, flange- or wall-mount with leg kit GEN 3 Enclosure. We're here to help.

**For enclosure parts, service, and literature, contact Trystar directly. You may also visit Trystar online at: [www.trystar.com](http://www.trystar.com).**

**In North America:**

*Call +1-507-333-3990.*

**For emergencies after hours:**

*Call +1-507-384-1750.*

### DISCLAIMER

*The installation instructions provided in this document are intended to ensure the safe and proper installation of the specified equipment when performed in accordance with the stated instructions. Trystar, LLC has verified that the technical content of the instructions is accurate and reliable based on current engineering standards, design and testing data. However, these instructions must be followed exactly as written. Failure to comply with the instructions specified herein will void any warranty, guarantee, or liability coverage provided by Trystar, LLC. Trystar, LLC shall not be liable for any loss, injury, or damage (including, but not limited to , consequential, indirect, or incidental damages, and including damages due to loss of use, income, profit, business or reputation, even if Trystar, LLC has been advised of the possibility of such damages) arising out of or in connection with any non-compliance with these installation instructions.*

**TRYSTAR, LLC'S TOTAL LIABILITY, IF ANY, FOR ANY CLAIM RELATED TO THE INSTALLATION OF THIS EQUIPMENT, WHETHER ARISING OUT OF BREACH OF CONTRACT, TORT, (INCLUDING NEGLIGENCE), STRICT LIABILITY OR OTHER LEGAL OR EQUITABLE THEORY, SHALL NOT EXCEED THE PURCHASE PRICE OF THE PRODUCT SOLD.**

*Any deviation from the prescribed installation instructions must be approved in writing by Trystar, LLC prior to execution.*

**NOTICE:** *The installation instructions defined herein are applicable to the specified enclosures and must be executed by qualified personnel using equipment rated and configured per this document. The qualified installer shall ensure compliance with all applicable local, state and federal safety standards, regulations and laws. Trystar, LLC assumes no responsibility for deviations from these instructions.*

## 11—PHASE ROTATION MONITOR TEST PROCEDURE REPORT

The Trystar GEN 3 Series phase rotation monitor is now set up in accordance to the procedure shown in **Section 8**. The phase rotation monitor will light when it detects

(Circle 1 or 2 below):

1. A **clockwise rotation** corresponding with that of the facility
  
2. A **counter-clockwise rotation** corresponding with that of the facility.

Sign and date this form. When another person hooks up a temporary generator, they can be sure that the phase rotation monitor is set up correctly.

I, \_\_\_\_\_, hereby certify the phase rotation monitor in this unit has been set in accordance with the procedure in **Section 8**.

X \_\_\_\_\_

DATE: \_\_\_\_/\_\_\_\_/\_\_\_\_



