



**TS60**  
**TS120**  
**TS180**

# Welcome to Trystar's GridPak™

---

Thank you for purchasing a GridPak sustainable power solution from Trystar. You can be confident in its engineering and craftsmanship. Trystar is known nationwide for providing highly engineered, durable, and unique power conveyance, conversion, testing, control, and power generation solutions. It is guided in this endeavor by its relentless focus on its customers and its passion for understanding their power management needs and challenges. GridPak represents Trystar's first step in helping customers reduce their carbon footprints with a renewable power generation solution.

## Focusing on a Sustainable Future

The GridPak is an alternative to a portable commercial diesel- or gas-powered generator. A formidable solar array and banks of lithium-iron phosphate (LiFePO<sub>4</sub>) batteries combine to produce up to 24 kW of power with 60 kWh, 120 kWh, and an optional 180 kWh of power. The GridPak solar array collects 320 kWh of energy (eight-hour day) weekly. Operators can parallel up to four GridPaks to generate as much as 720 kWh of carbon-free power.

GridPak represents an investment in zero-emissions equipment. More importantly, as part of your fleet, GridPak will help meet the growing customer demand for equipment designed for low- or zero-carbon emissions. GridPak can be part of your "transform-to-win" formula and your firm's legacy in preserving our finite natural resources.

In addition to three GridPak models, Trystar is developing an entire family of renewable energy products, including three PowerPak models. The PowerPak comes without the solar array but features battery energy storage (60 kWh/120 kWh/180 kWh) supported by a 6.5 kW onboard generator. Accessories include the ParallelPak, which allows the operator to parallel any combination of up to four GridPaks or four PowerPaks. Standard and quick-charge EV charging station accessories are also available.

## The Trystar Story

Trystar began as a welding cable supplier located in southern Minnesota. This business model was maintained until 1998, when Trystar started manufacturing its welding cable in-house. From there, Trystar also started manufacturing portable power cable. Recognizing a need for more reliable and efficient power distribution at construction sites, events, and other temporary locations, the company began to manufacture portable power distribution equipment that could withstand the rigors of construction sites and rental environments. The company quickly acquired a reputation for producing high-quality, durable, easy-to-use products.

Today, the portfolio of Trystar products is even better. Its solutions are engineered and built in a state-of-the-art facility using the highest quality materials, top-of-the-line production equipment, and industry-leading engineering practices. Third-party laboratories also test Trystar products. It's why its products last significantly longer than the competitors' even under the most demanding conditions.

The company has also grown significantly since its founding. Additional manufacturing sites in Texas, Michigan, Tennessee, Wisconsin, New Hampshire and Quebec complement its Faribault, Minnesota manufacturing site and headquarters. Its product lines have expanded to include a broader range of portable and permanent power solutions, including power distribution panels, I-Lines, transformers, portable automatic transfer switches (ATS), and welding racks. It also manufactures generator docking stations, load banks, and UL-891-rated switchboards. Trystar cable products include portable and industrial power, welding, utility and medium-voltage cables. Trystar's Michigan-based location specializes in emergency lighting inverters, power

## Welcome to Trystar's GridPak™

---

conditioning and voltage regulation equipment, industrial DC power supplies (rectifiers), and uninterruptible power solutions. Trystar's Texas-based operation manufactures prefabricated conventional and blast-proof remote instrument enclosures (REIs) and E-Houses. Trystar's New Hampshire operation adds depth to Trystar's inverter portfolio. It also offers energy storage conversion systems, bi-direction DC power supplies, printed circuit power supplies for motor drives and inverters, and silicon-controlled rectifier (SCR) controllers and firing boards. The Tennessee operation specializes in sophisticated electrical power system monitoring devices including sequence-of-event recorders and time reference/synchronization hubs. The most recent additions to Trystar's expanding product portfolio include industrial controls, monitoring and protection products, as well as industrial AC and DC uninterruptible power systems, DC to AC inverters, and AC to DC rectifiers. The GridPak family of solutions is one of the latest additions to the product portfolio.

Despite its growth, Trystar remains committed to its roots as a family-owned business focusing on quality and customer service. Experts are standing by to ensure customers get the correct information and the products needed for their requirements. If you require help in the field, Trystar will be there. And, if there's ever an issue, Trystar puts a team on the road to make things right. Exceptional service levels remain a company value.

Trystar also has a proven reputation for on-demand engineering capabilities, wherein it designs custom solutions. Trystar also values your time. In addition to providing service, management built the company around deadlines and response to urgent needs. Accordingly, it builds extra capacity and flexibility into every aspect of the production process to meet customer timelines. Further, with a strong reputation for reliability and innovation, the company is poised for continued success in the portable and permanent power solutions market.

Today, Trystar serves a broad array of industries, including utility, manufacturing, oil and gas, mining, industrial, military, emergency services, healthcare, entertainment, and infrastructure. Its global customer base includes many Fortune 500 companies and government agencies.

### About the Trystar GridPak™ Operating Manual

The GridPak Operating Manual is organized into several easy-to-read sections. These include:

- Welcome
- Table of Contents
- Important Safety Instructions
- Introduction
- Overview
- Operation
- Cleaning/Maintenance
- Changing LP Tanks
- Manual Programming
- Reporting Safety Defects

## Welcome to Trystar's GridPak™

---

It is vital for Owners/Operators to read and retain the information contained in the Safety section of this manual. Many Warnings, Cautions, and Notices are explained upfront, but others are distributed throughout the manual in appropriate areas.

The most significant section of the operating manual is dedicated to operation. GridPak is a complex, sophisticated device. Yet, it is engineered for simple operation. The operating system provides step-by-step guidance through the primary set-up stages: Deployment, Operation, and Retraction. Owners/operators interface with the device through a large color LCD screen. Operation is intuitive.

Other important sections include Maintenance and Troubleshooting. Simple and regular maintenance can prevent difficulties and enhance GridPak's performance and life. Please note that the Manual Programming section is designed for expert use, although it is easily accessible and unrestricted. Sometimes, an owner/operator may elect to use only certain features (e.g., batteries only) or manually program operating features (e.g., outriggers) to facilitate changing a trailer tire or other tasks. Again, these advanced programming and interface alternatives and features are highly intuitive.

### Trystar Customer Service

Trystar's primary goal is to ensure its customers are delighted with the performance and durability of its products. Please call us with any questions about the safety, operation, or performance of your GridPak. We're here to help.

For GridPak parts, service, and literature, contact Trystar directly. You may also visit Trystar online at [www.trystar.com](http://www.trystar.com).

#### In North America:

Call +1-507-333-3990. For emergencies after hours, call +1-507-384-1750.

# Table of Contents

---

1.	IMPORTANT SAFETY INSTRUCTIONS	
1.1	Overview .....	9
1.2	Warning, Caution, and Note Styles Used in the GridPak™ Operating Manual .....	9
1.3	General Safety Precautions.....	9
1.4	Automatic Backup Generator Start Hazard .....	11
1.5	Electrical Shock and Arc Flash Can Cause Severe Personal Injury or Death.....	12
1.6	Generator Voltage is Deadly.....	12
1.7	LP Gas is Combustible .....	12
1.8	Engine Exhaust/Carbon Monoxide is Deadly.....	13
1.9	Battery Gas is Explosive.....	14
1.10	Lithium-Iron Phosphate Battery Energy Storage Systems Pose Hazards If Damaged, Overloaded, or Mishandled.....	14
1.11	Moving Parts Can Cause Severe Personal Injury or Death.....	14
1.12	California Air Resources Board .....	15
1.13	Onboard Backup Generator Set Operation and Warning Labels .....	15
2.	INTRODUCTION	
2.1	About this Manual .....	16
2.2	Related Literature .....	16
2.3	Model Identification.....	16
2.3.1	Nameplate Location.....	17
2.4	How to Obtain Service.....	17
2.4.1	Information to have Available .....	17
2.5	Notes for the Rental Operation/Retailer.....	18
2.5.1	Power Draw for Planned Loads.....	18
2.5.2	Power Type Requirements.....	18
2.5.3	Cable Requirements.....	18
3.	OVERVIEW	
3.1	GridPak Specifications .....	19
4.	OPERATION	
4.1	Key Component Locations.....	20
4.2	GridPak Operating and Load Connector Panel .....	22
4.3	Deploying GridPak .....	23
4.3.1	Site the Trystar GridPak.....	23
4.3.2	Disconnect Trailer from Tow Vehicle.....	24
4.3.3	Siting GridPak by Forklift.....	26
4.3.4	Setup Sequence .....	29
4.3.5	Prepare for Outrigger Deployment.....	30
4.3.6	Deploy Outrigger Stabilization System.....	32
4.3.7	Preparing Solar Array for Deployment.....	37
4.3.8	Deploy Solar Mast and Array.....	38
4.3.9	Enable or Skip GPS Solar Array Tracking.....	38
4.3.9.1	Enable GPS Solar Array Tracking.....	39
4.3.9.2	Skip GPS Solar Array Tracking .....	40

# Table of Contents

---

4.	OPERATION	
	4.3.10 Power Loads .....	41
	4.3.10.1 Connect Unswitched/Dead Loads .....	43
	4.3.10.2 Drape Load Service Cables.....	43
	4.3.10.3 Close Power Cable Receptacle Door .....	43
	4.3.10.4 Ensure Preparedness to Power Up the GridPak.....	43
	4.3.10.5 Power Up GridPak .....	44
	4.3.10.6 Switch On Loads at Source.....	45
4.4	Operating GridPak.....	46
	4.4.1 Operating Status .....	46
	4.4.2 Battery Energy Level .....	47
	4.4.3 Output Load.....	47
	4.4.4 Grid Power.....	47
	4.4.5 Generator Power .....	48
	4.4.6 Solar Energy .....	48
	4.4.7 Charging GridPak.....	49
4.5	Powering Down GridPak.....	50
	4.5.1 Power Down Connected Loads.....	50
	4.5.2 Power Down GridPak.....	51
	4.5.3 Retract Solar Array .....	52
	4.5.4 Retract Outriggers.....	55
	4.5.5 Prepare GridPak for Transit.....	58
	4.5.6 Stow All Load Devices .....	58
	4.5.7 Position Tow Vehicle and Trailer Tongue Jack for Hitch Connection .....	58
	4.5.8 Reconnect Trailer to Tow Vehicle.....	59
	4.5.9 Sleep GridPak Operating System .....	61
	4.5.10 Final Transit Inspection .....	62
5.	CLEANING/MAINTENANCE	
	5.1 Cleaning.....	63
	5.2 Cleaning/Protecting Solar Array .....	63
	5.3 Deployment/Retraction Mechanism Lubrication.....	64
6.	CHANGING LP TANKS	
	6.1 Key Component Locations and Hardware .....	66
	6.2 Accessing LP Cabinet Panel .....	68
	6.3 Disconnecting LP Tank Hardware .....	69
	6.4 Removing Empty LP Tanks.....	70
	6.5 Reconnecting Hardware to Full LP Tanks .....	71
	6.6 Turn on LP Fuel Tanks .....	72
	6.7 Close and Lock LP Fuel Tank Enclosure .....	72
7.	MANUAL PROGRAMMING	
	7.1 Entering Manual Programming.....	73
	7.2 AC Power Programming.....	74
	7.2.1 AC Power Tab Screen Meters .....	75
	7.2.2 Utility Charging High Power .....	77

# Table of Contents

---

7.2.3	Utility Charging Low Power .....	77
7.2.4	Generator Charging.....	78
7.2.4.1	Generator Contactor Operation.....	78
7.2.5	Exiting Programming Mode.....	79
7.3	Outrigger Manual Programming .....	80
7.3.1	Manually Deploy Outriggers .....	82
7.3.2	Manually Extend Outrigger Arms .....	82
7.3.3	Manually Lower Outrigger Legs .....	83
7.3.4	GridPak Level Meters.....	84
7.3.5	Exiting Programming Mode.....	84
7.4	Solar Tower/Array Manual Programming .....	85
7.4.1	Deploy Solar Array Tower .....	86
7.4.2	Deploy Solar Arrays.....	87
7.4.3	Exiting Programming Mode.....	88
7.5	Manually Home, Rotate and Tilt Solar Array Functions.....	89
7.5.1	Home Solar Array for Manual Rotation .....	92
7.5.2	Home Solar Array for Manual Tilt .....	92
7.5.3	Manually Rotate Solar Array.....	93
7.5.4	Manually Rotate Solar Array for Stowage .....	94
7.5.5	Manually Tilt Solar Array.....	94
7.5.6	Manually Tilt Solar Array for Stowage .....	95
7.5.7	Exiting Programming Mode.....	96
7.6	Manually Monitor Environmental Functions .....	97
7.6.1	Exiting Programming Mode.....	101
7.7	Manually Program Solar Tracking and Charging .....	102
7.7.1	Manually Program Solar Tracking.....	103
7.7.2	Solar Tracking Control Meter Interpretation.....	104
7.7.2.1	Azimuth/Rotation Interpretation .....	104
7.7.2.2	Elevation/Tilt Interpretation .....	105
7.7.3	Manually Program Solar Charging .....	105
7.7.3.1	Enable Manual Solar Charging .....	105
7.7.4	Enable Manual Auxiliary Solar Charging.....	107
7.7.5	Exiting Programming Mode.....	108
7.8	Manually Program Weather Tower .....	109
7.8.1	Manually Stow Weather Tower.....	110
7.8.2	Manually Deploy Weather Tower .....	111
7.8.3	Manually Monitor Wind Speed .....	111
7.8.4	Manually Monitor Temperature.....	112
7.8.5	Manually Disable Automatic Array Retraction .....	112
7.8.6	Enable Automatic Array Retraction.....	113
7.8.7	Existing Manual Programming.....	113
7.9	Manually Program Generator.....	114
7.9.1	Manually Start Generator.....	116
7.9.2	Manually Stop Generator .....	117
7.9.3	Manually Enable/Disable Automatic Charging .....	117
7.9.3.1	Manually Disable Automatic Charging.....	118
7.9.3.2	Manually Enable Automatic Charging.....	118

# Table of Contents

---

7.9.4	Manually Set State of Charge Minimum/Shutoff.....	119
7.9.4.1	Manually Set State of Charge Minimum .....	119
7.9.4.2	Manually Set State of Charge Shutoff.....	120
7.9.5	Exiting Programming Mode.....	120
7.10	Service Technician Programming .....	121
7.10.1	Exiting Programming Mode .....	121
8.	REPORTING SAFETY DEFECTS	
8.1	Contact Information .....	122

## 1.0 IMPORTANT SAFETY INSTRUCTIONS

### 1.1 Overview

Please read the GridPak™ Operator Manual thoroughly before operating the GridPak portable power system. It contains important safety information. It also contains instructions that should be followed during operation and maintenance. Optimum performance and safe operation depend on proper operation and maintenance of the GridPak. Owners and operators of GridPak are solely responsible for its safe operation.

GridPak operation, maintenance and installation must comply with all applicable local, state, and federal codes and regulations. Electricity, exhaust, fuel (e.g., LP), moving parts and both lead-acid and lithium-iron phosphate batteries all present hazards which can result in severe personal injury or death. Only trained and experienced personnel with knowledge of fuels, hydraulics, electricity, and machinery hazards should perform GridPak operation, maintenance or otherwise dispose of GridPak.

### 1.2 Warning, Caution, and Note Styles Used in the GridPak Operating Manual

The following symbols and graphic styles found throughout the GridPak Operating Manual indicate potentially hazardous conditions for the operator, service personnel, or equipment.

#### DANGER

*Indicates an imminently hazardous situation that, if not avoided, will result in death or serious injury.*

#### WARNING

*Indicates a potentially hazardous situation that, if not avoided, could result in death or serious injury.*

#### CAUTION

*Indicates a potentially hazardous situation that, if not avoided, could result in minor or moderate injury.*

#### NOTICE

*Indicates information considered important but not hazard related.*

### 1.3 General Safety Precautions

#### WARNING

Operation of GridPak is unsafe when mentally or physically fatigued. Do not operate GridPak in this condition or after consuming any alcohol or drugs.

#### WARNING

Any maintenance (other than that referenced) and repairs should be performed when GridPak and any incoming power is disabled. Only qualified technicians know the proper procedures.

#### WARNING

Hydraulic system is under high pressure. High pressure lines with punctures can lead to operators or bystanders being sprayed by hydraulic fluid which is harmful and flammable. Only qualified technicians should service the hydraulic system and components.

## 1.0 IMPORTANT SAFETY INSTRUCTIONS

### 1.3 General Safety Precautions

#### WARNING

Transporting, siting, operating (deployment, operation, and retraction) and maintaining GridPak can cause severe personal injury. Wear personal protective equipment (PPE) such as safety glasses, protective gloves, hard hats, steel-toed shoes, and protective clothing when working with GridPak.

#### WARNING

The lithium-iron phosphate battery energy storage system (BESS) is a non-operator/owner serviceable component. Do not attempt to service, open, or otherwise access the BESS or related power generation system. Contact an authorized GridPak technician and service organization for related service and maintenance.

#### WARNING

The backup LP-fueled generator on the GridPak uses combustible gas under pressure from a series of LP tanks. The LP is highly flammable and handled improperly, can cause severe personal injury or death. Do not attempt to service, open, or otherwise access the LP system. Only qualified and trained personnel should service the individual LP tanks and valves or refill the LP tanks. Contact Trystar for related service and maintenance to the LP system.

#### WARNING

The backup LP-fueled generator on the GridPak exhausts carbon monoxide and produces heat during operation. Inhaling the exhaust can cause serious medical conditions, including death. Hot metal parts can cause severe burns. Avoid contact with the generator while it is running or hot and avoid inhaling exhaust gases.

#### WARNING

The backup LP-fueled generator on the GridPak starts automatically to augment charging and BESS levels. Alternatively, it can be started following the procedure detailed in **Section 7** of this manual. Do not attempt to access it directly to start it. Contact Trystar for service.

#### WARNING

Used engine (LP backup generator) oils have been identified by some state and federal agencies to cause cancer or reproductive toxicity. Do not ingest, breathe the fumes, or contact used oil when checking or changing engine oil.

#### WARNING

When moving/transporting the GridPak by forklift or similar vehicle, ensure forklift forks do not touch the lithium-ion battery banks which are located underneath and adjacent to the forklift pockets. Make sure that the forks fully engage with the forklift pockets on the opposite side before lifting. Failure to heed this warning could result in the batteries being punctured resulting in a lithium fire.

## 1.0 IMPORTANT SAFETY INSTRUCTIONS

### 1.3 General Safety Precautions

#### WARNING

Do NOT use the four eye bolts on the bottom of the GridPak chassis to move it. The eye bolts are designed to help secure the GridPak to a flatbed trailer for transport needs only. The eye bolts cannot support the weight of GridPak. If the eye bolts are hooked directly to a lifting device, they will be ripped from GridPak at approximately 4000 lbs. of force (potentially while it's in the air).

#### CAUTION

To prevent accidental starting while working on the backup generator set, make sure the GridPak and generator system are off. See **Section 7** of this manual to disable automatic startup.

#### CAUTION

Unsecured or loose fasteners and panel doors can cause equipment damage. Make sure all fasteners, nuts, bolts, and access panels are secured and/or properly torqued.

#### CAUTION

Do not place any tools, equipment or other items on top of the solar array when retracted or underneath it when it is being retracted from an elevated position to avoid breaking or damaging the solar panels and to prevent injury to the operator or bystanders.

#### NOTICE

The GridPak is equipped with emergency shutoff buttons on sides and at the control system panel. Owners and operators should familiarize themselves with their locations to shut down GridPak operation in an emergency.

#### NOTICE

Keep multi-class ABC fire extinguishers handy. Class A fires involve ordinary combustible materials such as wood and cloth. Class B fires involve combustible and flammable liquid fuels and gaseous fuels. Class C fires involve live electrical equipment. (Refer to NFPA No. 10 in applicable region.)

### 1.4 Automatic Generator Start Hazard

#### WARNING

When the GridPak is operating, the backup LP-fueled generator may start automatically causing severe personal injury or death whenever maintenance or inspections are being performed. Turn off the GridPak and disable the generator automatic start feature before performing inspection, service, or maintenance. See **Section 7** of this operating manual.

## 1.0 IMPORTANT SAFETY INSTRUCTIONS

### 1.5 Electrical Shock and Arc Flash Can Cause Severe Personal Injury or Death

#### WARNING

Electrical shocks and arc flashes can cause severe personal injury or death. Adhere to the following guidelines:

- Only Trystar should work on the battery energy storage system (BESS) and exposed power circuits.
- All relevant service records should be available to certified service technicians and organizations prior to any electrical work they perform.
- Exposure to energized power circuits with potentials of 50 VAC or 75 VDC or higher poses a significant risk of electrical shock and electrical arc flash.
- Refer to standard NFPA 70E, or equivalent safety standards in corresponding regions, for details of the dangers involved and for safety requirements.

### 1.6 GridPak Generator and GridPak Backup Generator Voltage is Deadly

#### WARNING

Loads connected to GridPak and other electrical connections should be made by a trained and experienced electrician in accordance with electrical codes. Improperly connected loads can cause equipment damage, severe personal injury, or death.

#### WARNING

Improper applications of GridPak can cause equipment damage, severe personal injury or death. All applications should be evaluated and GridPak operation conducted by trained and experienced personnel in accordance with its operating and safety instructions as well as any applicable codes.

#### WARNING

Live electrical equipment, including GridPak and connected loads, can cause electrocution. Be cautious when working on live electrical equipment. Remove jewelry, make sure shoes and clothing are dry, stand on a rubber insulating mat, and use tools with insulated handles.

### 1.7 LP Gas is Combustible

#### WARNING

Liquefied petroleum gas (LPG), e.g., LP, is highly combustible. Adhere to the following information to avoid igniting the fuel:

- Fuel tank service, repairs, inspection, and filling should only be conducted by a trained and experienced technician
- Do not smoke or turn electrical switches on or off where fumes are present or in areas sharing ventilation with fuel tanks or equipment.

## 1.0 IMPORTANT SAFETY INSTRUCTIONS

### 1.7 LP Gas is Combustible

#### WARNING

Liquefied Petroleum Gas (LPG), e.g., LP, is highly combustible. Adhere to the following information to avoid igniting the fuel:

- Keep flames, sparks or arc-producing equipment and all other sources of ignition well away from GridPak's onboard fuel tanks.
- Fuel tanks should remain in their originally-installed locations during GridPak operation.
- Do not drop, bump, or expose tanks to damage leading to leaks or ruptures during operation or service when GridPak is not operating.
- Fuel lines between GridPak fuel tanks and backup LP-fueled generator must remain secured, free of leaks and separated and shielded from electrical wiring.

### 1.8 Engine Exhaust/Carbon Monoxide are Deadly

#### WARNING

Substances in exhaust gases have been identified by some state and federal agencies to cause cancer or reproductive toxicity. Do not breathe in or come into contact with exhaust gases from the GridPak backup LP-fueled generator should it be operating.

#### WARNING

Carbon monoxide is a poisonous gas. Inhalation can cause severe personal injury or death. Apply information contained in the following to make sure carbon monoxide is not being inhaled by owners, operators or others working around or in the vicinity of the GridPak backup LP-fueled generator should it be operating.

- Do not allow the backup LP-fueled generator to operate in an enclosed space such as a garage or building of any kind without proper ventilation.
  - Do not use an operating GridPak backup LP-fueled generator to heat a working or living space.
- Carbon Monoxide (CO) is odorless, colorless, tasteless, and non-irritating. It cannot be seen or smelled. Exposure, even to low levels of CO for a prolonged period can lead to asphyxiation (lack of oxygen).

Mild effects of CO poisoning include:

- Headache
- Dizziness
- Drowsiness
- Fatigue
- Chest Pain
- Confusion

More extreme symptoms include:

- Vomiting
- Seizure
- Loss of consciousness
- Death

## 1.0 IMPORTANT SAFETY INSTRUCTIONS

### 1.9 Battery Gas is Explosive

#### WARNING

GridPak uses lead-acid batteries to start its backup LP-fueled generator and to supply energy to other onboard electronics. Battery gas is highly explosive and may cause severe personal injury or death if ignited. Take proper precautions to avoid personal injury.

- For personal safety, wear appropriate personal protective equipment (PPE) when working on or around the backup LP-fueled generator.
- To make sure battery gas is not ignited, do not smoke or use flame devices around the generator set (or battery)
- To reduce arcing when disconnecting or reconnecting battery cables, always disconnect the negative (-) battery cable first and reconnect it last.

### 1.10 Lithium-Iron Phosphate (LiFePO<sub>4</sub>) Battery Energy Storage Systems (BESS) Pose Hazards If Damaged, Overheated or Mishandled

#### WARNING

GridPak uses lithium-iron phosphate battery energy storage systems (BESS). They are not owner/operator serviceable. Improper service or mishandling of the BESS can lead to electrical shock, severe personal injury, or death. If damaged, the BESS can ignite and/or release dangerous hydrogen fluoride gas. Only trained and authorized GridPak technicians should inspect, service, or repair GridPak's BESS.

### 1.11 Moving Parts Can Cause Severe Personal Injury or Death

#### WARNING

Moving parts can cause severe personal injury or death, and hot exhaust parts (e.g., backup LP-fueled generator) can cause severe burns. Make sure all protective guards, safety devices, and enclosures are properly in place before starting or working around or on GridPak.

#### WARNING

Hot moving and electrically-live parts can cause severe personal injury or death. Keep non-owner/operator and/or non-trained or non-certified professionals away from GridPak. Only trained and experienced personnel should deploy, operate, retract and transport GridPak.

#### WARNING

Moving parts can catch on loose items such as clothing or jewelry. Do not wear loose clothing or jewelry near moving parts such as outriggers, solar array, and the backup LP-fueled generator.

#### WARNING

Moving parts can entangle appendages such as arms, hands, fingers, legs, and feet. Keep any protective guards, safety devices and enclosures over/around moving parts during deployment, operation, retraction and transit of GridPak. Keep body appendages safely away from any moving parts.

## 1.0 IMPORTANT SAFETY INSTRUCTIONS

---

### 1.12 California Air Resources Board (CARB)

 **CAUTION**

Unauthorized modifications or replacement of fuel, exhaust, air intake, or speed control system components that affect engine emissions are prohibited by law in the state of California. See the Operating/Owner's Manual for the backup LP-fueled generator onboard GridPak.

### 1.13 Onboard Backup Generator Set Operation and Warning Labels

Owner/operators may refer to the backup LP-fueled generator manufacturer's Owner/Operator Manual for proper operation, warnings, cautions and notes. However, generator service should be performed by Trystar.

## 2.0 INTRODUCTION

---

### 2.1 About this Manual

This is the Operator Manual for Trystar's GridPak portable power system. Each respective operator should study this manual carefully, observing all of its instructions and safety precautions. Please keep this manual readily available for reference.

The information contained within this manual is based on information available at the time of printing. Information may change at any time without notice. Users should ensure they have the latest information available before operation and service. The latest edition of this manual can be found online at: [www.Trystar.com](http://www.Trystar.com).

The Operation, Maintenance and Manual Programming chapters of this manual provide instructions necessary for operating GridPak and for providing simple maintenance to achieve top performance. The owner is responsible for performing maintenance in accordance (only) with the information provided. Any service or maintenance required beyond that contained in this operating manual necessitate contacting Trystar.

The manual also includes GridPak specifications and information on how to obtain service.

### 2.2 Related Literature

Before operating GridPak, operators should take time to read all of the manuals supplied with it and familiarize themselves with the warnings and operating procedures.

The relevant and most current manuals for the onboard backup LP-fueled generator can be found, using the model number of the generator set at: <https://www.social.cummins.com/cm-generator-manuals> or <https://quickserve.cummins.com>.

Each GridPak is provided with a nameplate on the trailer tongue that contains the VIN number. This information is needed when contacting Trystar for Trystar parts, service, and product information. Please take note of this information and record it in the space provided.

#### CAUTION

The backup LP-fueled generator must be operated and maintained properly for safe and reliable operation. Please contact Trystar to arrange for service and maintenance.

### 2.3 Model Identification

Each GridPak is provided with a metal nameplate on the trailer tongue that contains a VIN number. This information is needed when contacting Trystar or an authorized service center for Trystar parts, service, and product information. Please take note of this information and record it in the space provided.

## 2.0 INTRODUCTION

---

### 2.3 Model Identification

Similarly, the Cummins backup LP-fueled generator has a nameplate with model and serial numbers. This information will be provided to you but please record these numbers in the designated space below as well.

#### 2.3.1 Nameplate Location

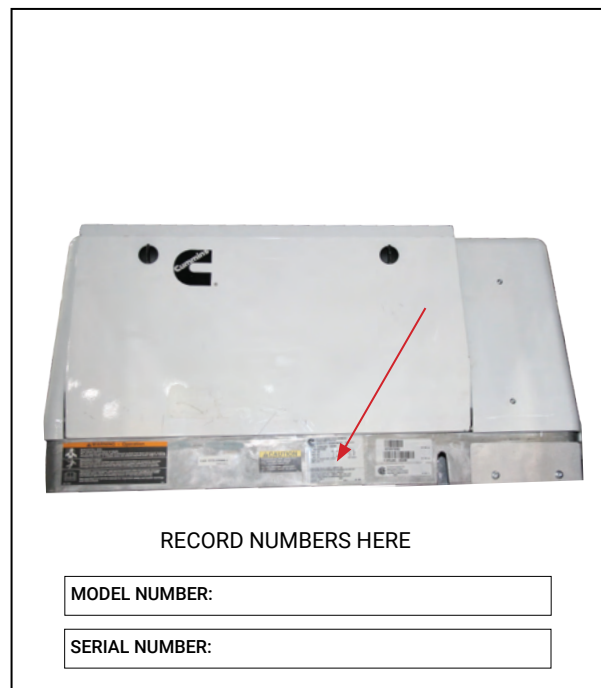

### 2.4 How to Obtain Service

For GridPak parts, service, and literature in North America, please contact Trystar: +1-507-333-3990. For emergencies after hours: +1-507-384-1750.

#### 2.4.1 Information to Have Available

- VIN Number
- Date of Purchase
- Nature of the Problem

## 2.0 INTRODUCTION

---

### 2.5 Notes for the Rental Operation/ Retailer for the GridPak

In addition to recording the usual customer information, it is advisable to collect additional details relative to use in order to ensure the GridPak will meet the customers' needs and will be able to operate safely and efficiently.

#### 2.5.1 Power Draw for Planned Loads

Before renting GridPak to a customer, ascertain the type of loads they plan to power along with the wattage/amperage/volts required by each. Calculate the draw of those loads in aggregate to ensure that the GridPak has the appropriate capacity. GridPak capacity and other specifications are noted in **Section 3.1** of this operating manual.

#### 2.5.2 Power Type Requirements

GridPak has only a single three-phase output. Trystar sells three-phase breakout boxes if more than one three-phase load is powered but this should be evaluated carefully. Multiple three-phase loads could easily exceed GridPak's output capabilities.

#### 2.5.3 Cable Requirements

In addition to power type requirements, corresponding cable requirements should be determined so GridPak is loaded with the necessary accessories prior to departure.

### 3.0 OVERVIEW

#### 3.1 GridPak Specifications

Output Power	
Continuous Output Power (Battery + Generator)	24 kW (48 kW Option) + 6.5 kW
Peak Battery Power	60kW
Output Voltage Options	120 VAC & 208 VAC (60 Hz) 1 Phase & 3 Phase
Output Voltage Capacities	67 A @208Y/120 V, 3 Phase 77 A @ 208 VAC, 1 Phase 200 A @ 120 VAC 1 Phase
Maximum Power Output of 4 Trailers	96 kW (3 Inverters) 192 kW (6 Inverters)
Battery Energy Storage	
Battery Capacities (Depending on Model)	60 kWh and 120 kWh or 180 kWh Option
Total Trailer Energy Capacity (Battery + Generator)	190 kWh and 250 kWh or 310 kWh Option
Battery Chemistry	Lithium-iron Phosphate (LiFePO <sub>4</sub> )
Solar Power	
Solar Array Power Deployed	5.7 kW
Solar Array Power Stowed	1.9 kW
Battery Charging Times (Calculated 60 kWh or 120 kWh Battery)	
Utility (30 kW)	2.5 Hrs. or 5.0 Hrs. (3 Inverters)
Utility (30 kW)	1.25 Hrs. or 2.5 Hrs. (6 Inverters)
Generator (Rated: 6.5 kW)	11 Hrs. or 22 Hrs.
Solar (5.7 kW)	10.5 Hrs. or 21.0 Hrs.
Onboard Generator	
Generator Power	6.5 kW (120 VAC/54 A)
Fuel Type & Storage	3 x 40 Lb. LP Tanks (28.2 Gal. Total)
Converted Energy	130 kW
Noise Level	70 dB(A) at 10 Ft.
Output Connectors	
Set of Female Cam Locks	120/208 VAC 3 Phase (100 A)
NEMA L21-20R Twist Lock	120/208 VAC 3 Phase (20 A)
3x CS6369 Twist Lock	120/208 VAC (50 A)
3x NEMA 5-30R	120 VAC (30 A)
6x NEMA 5-20R Standard Outlets	120 VAC (20 A)
Charging Ports	
Set of Female Cam Locks	120/208 VAC 3 Phase (100 A)
NEMA 5-20R	120V VAC (20 A) Standard Outlets

Solar Savings (Solar Array Lifetime 30 Yr. Minimum)	
Solar Energy Collected (8 Hrs. Peak Sun)	320 kWh/Week 500 MWh/Lifetime
Diesel Saved	31 Gal./Week (\$133 @ \$4.30 Fuel Cost) 48,268 Gal./Lifetime (\$208,000)
Carbon Offset	690 Lbs. CO <sub>2</sub> /Week 541 T CO <sub>2</sub> /Lifetime
Battery Savings (120 kWh, Battery Lifetime 10 Yr. Minimum)	
Battery Energy Utilized	840 kWh/Week 438 MWh/Lifetime
Savings Charging with Utility Compared to Diesel	\$290/Week (@\$4.30 Fuel Cost) \$151,000/Lifetime
Carbon Offset Charged with Renewables	1820 Lbs. CO <sub>2</sub> /Week 470 T CO <sub>2</sub> /Lifetime
Total Carbon Offset Opportunity (52 Week Year)	
Carbon Offset Charged with Renewables	2510 Lbs. CO <sub>2</sub> /Week 65 T CO <sub>2</sub> /Year 1011 T CO <sub>2</sub> /Lifetime
Solar Array	
Dual Axis Solar Tracking	
Elevation Angle	0° - 50°
Azimuth Rotation	± 175°
Array Dimensions	16.3' x 21.4'
User Interface	
24" Touch Screen User Interface for Monitoring Power System	
"Easy Deploy," Remote Monitoring / IOT	
Mechanical Specifications (60 kWh or 120 kWh)	
Deployed Dimensions (W x L x H)	16.3' x 26' x 21'
Stowed Dimensions (W x L x H)	8.5' x 26' x 8.3'
Total Weight*	14,000 or 16,000 Lbs.
Operating Temperatures	
System Operating Temperatures	-20° F to 130° F
Safety	
Nationally-Recognized Approved Subsystems	
Easily Accessible E-Stop Locations	

\*Without accessories and extra equipment

## 4.0 OPERATION

### 4.1 Key Component Locations

The figure below illustrates the components of a typical GridPak Solar Generator. There may be some variation depending on the GridPak model.

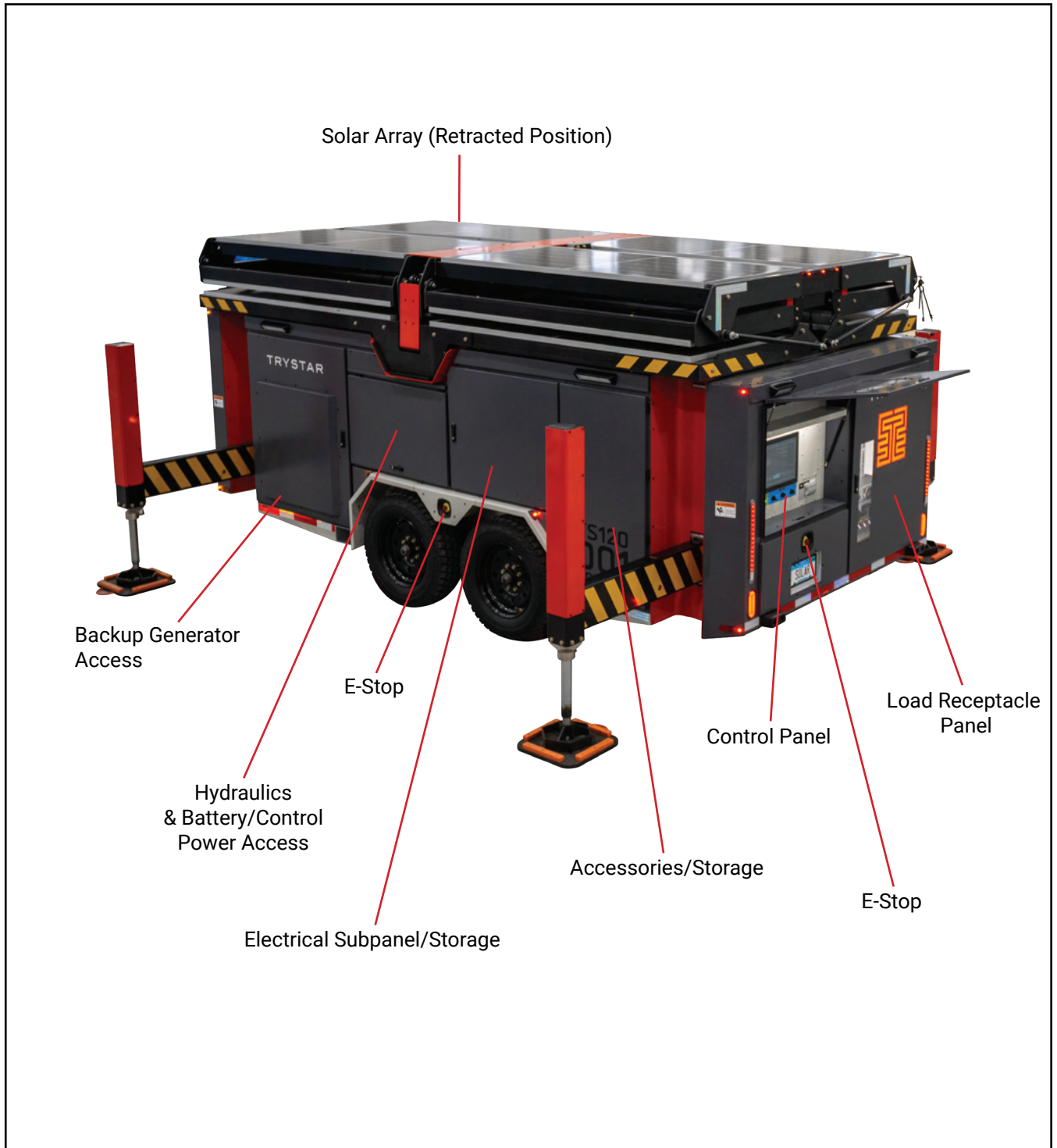

## 4.0 OPERATION

### 4.1 Key Component Locations

The figure below illustrates the components of a typical GridPak Solar Generator. There may be some variation depending on the GridPak model.



# 4.0 OPERATION

## 4.2 GridPak Operating System & Load Receptacle Panel

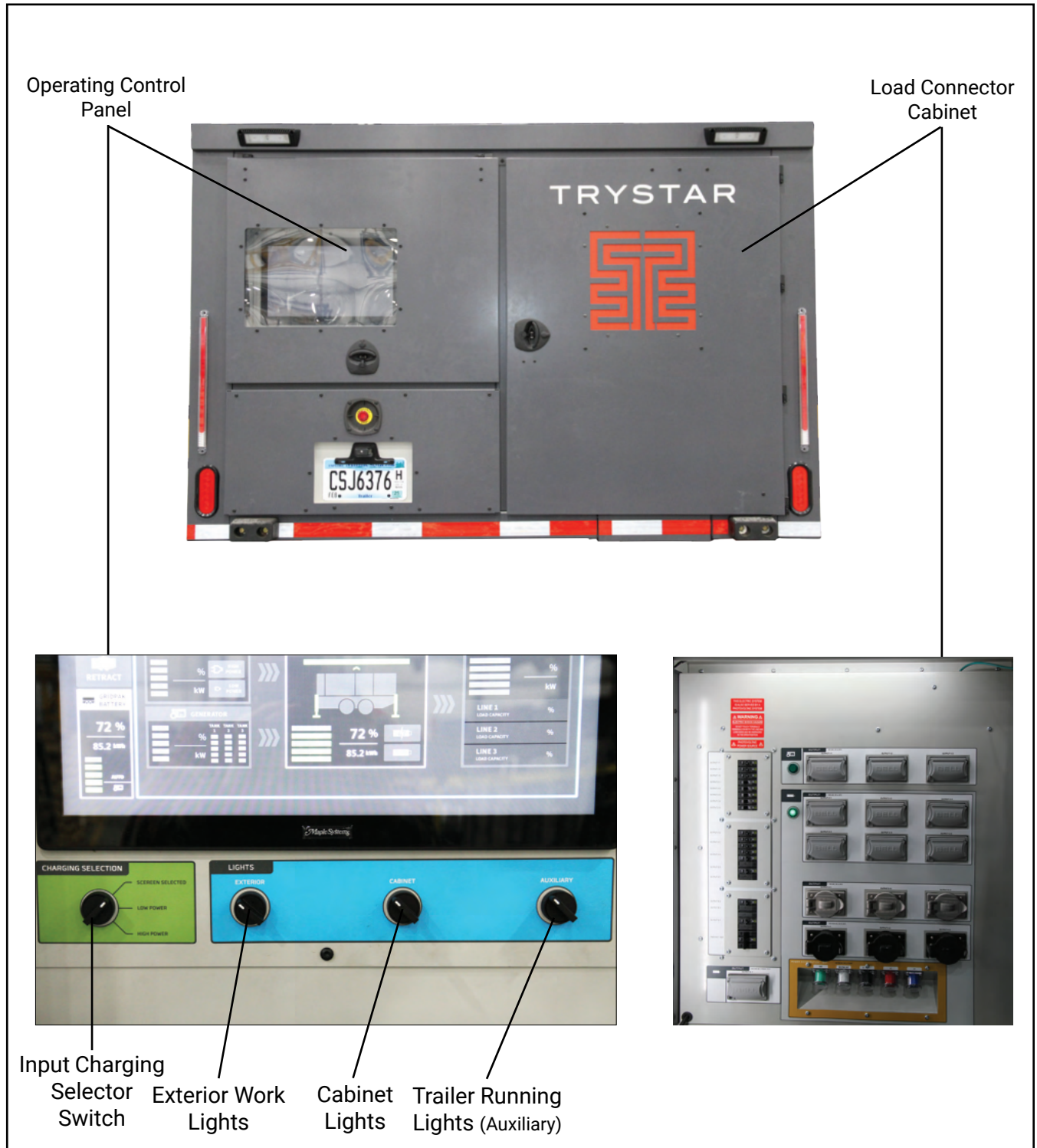

## 4.0 OPERATION

### 4.3 Deploying GridPak™

It is important to follow all safety precautions and the step-by-step process to maximize GridPak functionality. There are three major steps including: Siting GridPak, GridPak Deployment and GridPak Retraction/Transit.

NOTICE
Allow a minimum 15-feet of free space (clearance) from sides/ends and 35-feet unobstructed clearance above GridPak.

#### 4.3.1 Site the Trystar GridPak

To optimize operation, GridPak should be sited on firm level ground and away from peripheral and vertical obstructions. Situate the GridPak such that the long sides of the trailer face directly east and west (as much as possible) by pointing the trailer tongue due south. Properly siting the trailer minimizes the travel of the solar array as it follows the sun, thereby minimizing the initial use of energy to orient the array.

Allow a minimum of 15 feet of free space from both sides and ends of GridPak and 35 feet of clearance above it. Fully deployed, the vertical height (mast and solar panels) of GridPak is 21 feet. It requires an unobstructed view of the rising/setting sun. The solar array will tilt and rotate throughout daylight hours

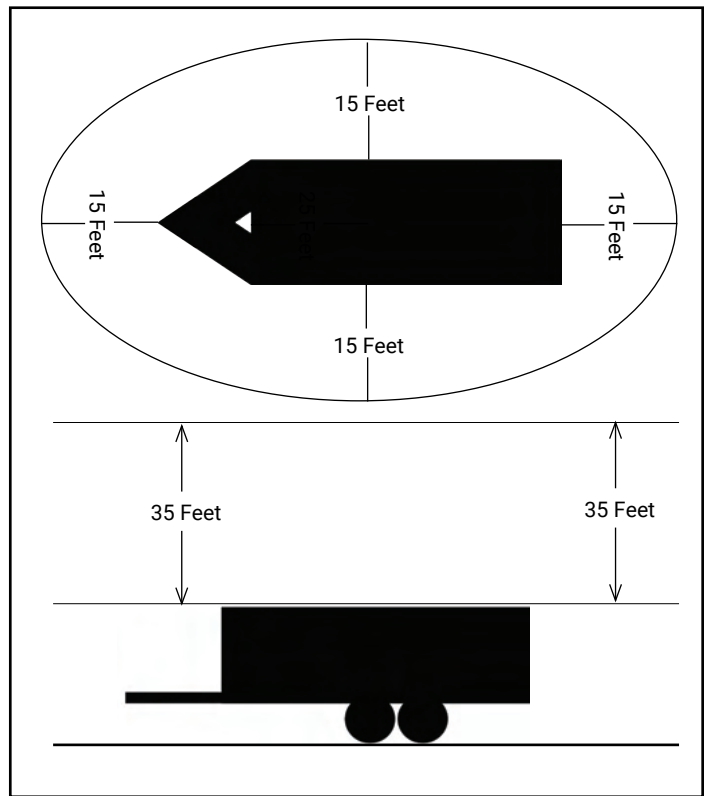

NOTICE
Keep the towing vehicle in "Park" and set the vehicle's emergency brakes before proceeding with the following steps:

- Ensure GridPak is close enough to load or input power to avoid having to reposition it
- Remove wheel chocks from the Accessory Storage cabinet
- Place wheel chocks firmly against tires on both sides of the trailer



## 4.0 OPERATION

### 4.3.2 Disconnect Trailer from Tow Vehicle

#### NOTICE

Ensure trailer brake/turn/running lights modular plugs between GridPak trailer and tow vehicle are disconnected. The trailer brakes engage automatically once the trailer brake plug is disconnected.

- Disconnect the brake/turn/running lights modular plug between GridPak and the tow vehicle
- Disconnect the safety breakaway cable between trailer and tow vehicle

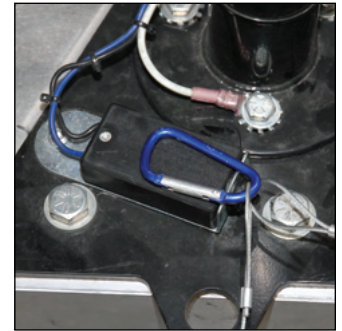

#### ⚠ CAUTION

Disconnecting the trailer from the tow vehicle can be dangerous and result in minor or moderate injury if it is not first secured in place. Make sure the trailer is secured so that any unexpected movement (e.g., rolling or trailer tongue swinging) does not result in an injury. Ensure the wheel chocks are firmly against the tires. Place orange safety cones around the GridPak.

Once the GridPak wheel chocks are firmly in place, it will be necessary to disconnect GridPak from the tow vehicle.

- Ensure wheel chocks are firmly against tires on both sides of the trailer



The GridPak trailer features an electrically-controlled hydraulic tongue jack to help lift the GridPak trailer off the tow vehicle hitch or otherwise clear the connection. The tongue jack control is mounted on the jack mast on top of the trailer tongue. There are two toggle switches: an on/off switch for illumination and a directional control switch.

- Disconnect the tow chains between trailer and tow vehicle



## 4.0 OPERATION

### 4.3.2 Disconnect Trailer from Tow Vehicle

**⚠ CAUTION**

Keep hands and feet away from the foot of the trailer tongue jack as it travels up/down to avoid injury.

- Switch the on/off toggle switch on the hydraulic jack mast to "on" to provide illumination should it be needed to facilitate connections
- Push the trailer jack rocker switch "down" to lift the trailer off the tow vehicle hitch and position such that the tow vehicle can be moved away from GridPak

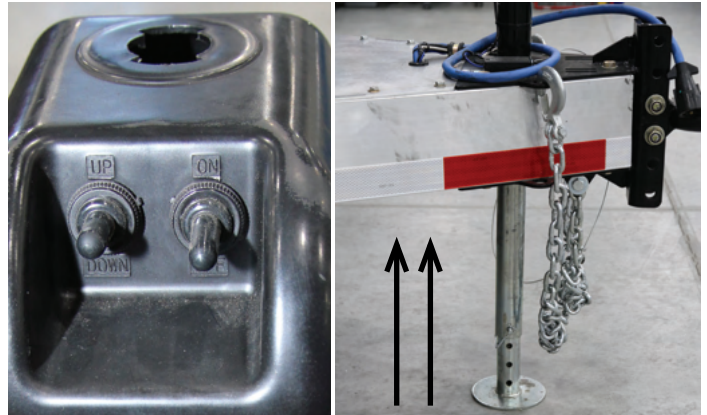

- Move the tow vehicle away from GridPak

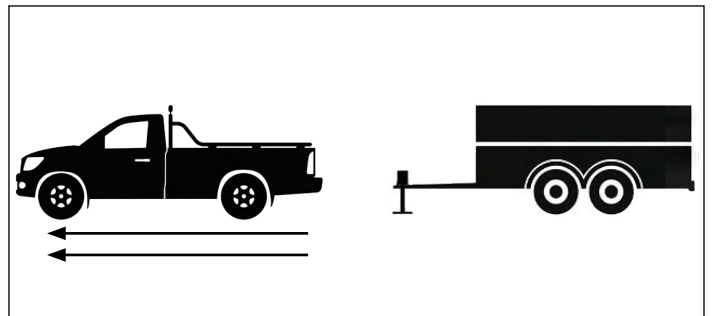

- Toggle the rocker switch button down slightly to ensure the GridPak is roughly level, front to back. This step helps facilitate a smooth and even deployment of the outriggers later in the process

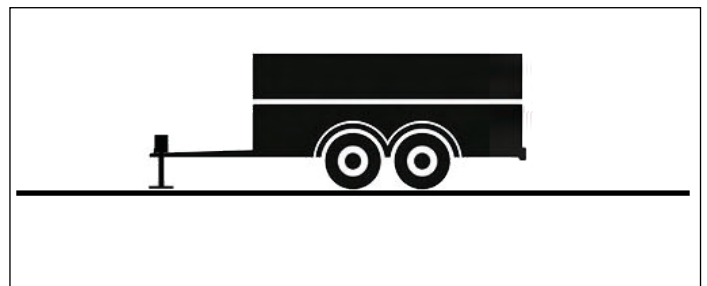

Leave the hydraulic jack at this height. It will help stabilize the GridPak when the outriggers are retracted and the trailer is returned to wheel-based support.

## 4.0 OPERATION

### 4.3.3 Siting GridPak by Forklift

#### ⚠ WARNING

Serious injuries or death can result from puncturing the GridPak's lithium-iron phosphate batteries. The battery banks are located underneath the GridPak above/adjacent to the forklift pockets. When moving/transporting by forklift or similar vehicle, ensure forklift forks do not touch the battery plates as they are being inserted/removed and that the forks fully engage with the forklift pockets on the opposite side before lifting. Failure to heed this warning could result in the batteries being punctured resulting in a lithium fire, the release of toxic fumes, and exposure to the electrolyte inside the battery. Lithium-iron phosphate fumes are harmful if inhaled and can cause respiratory problems and other health issues. The electrolyte inside the battery is highly corrosive and can cause serious damage to skin and eyes.

#### ⚠ WARNING

Do NOT use the four eye bolts on the bottom of the GridPak chassis to lift/move it. The eye bolts are intended ONLY to help secure the GridPak to a flatbed trailer such as may be towed by a semi-truck. **The four eye bolts cannot support the weight of GridPak.** If the eye bolts are hooked directly to a lifting device, they will be ripped from GridPak at approximately 4000 lbs. of force posing a risk of crushing and other severe injuries that could lead to death.

GridPak is typically transported as a trailerized unit pulled behind a heavy-duty truck. It can, however, be placed in its entirety on a flatbed trailer, safely secured, and pulled behind a semi-truck.

There is one way to lift the GridPak onto a semi-truck flatbed trailer. It is to use the integrated forklift pockets located in the chassis. It is critical to ensure the fork tines extend through the pockets on both sides of the chassis before lifting to ensure the battery banks are not accidentally scraped, dented, or punctured. SEE WARNING ABOVE.



## 4.0 OPERATION

### 4.3.3 Siting GridPak by Forklift

NOTICE
Allow a minimum 15-feet of free space (clearance) from sides/ends and 35-feet unobstructed clearance above GridPak.

Once the forklift lowers the GridPak to the ground, it should be momentarily controlled by the lifting apparatus. This pause will allow a second operator to secure it with wheel chocks and the hydraulic jack to prevent it from rolling, swinging or moving. Once secured, the forklift can be moved away.

To optimize operation, GridPak should be sited on firm level ground and away from peripheral and vertical obstructions. Situate the GridPak such that the long sides of the trailer face directly east and west (as much as possible) by pointing the trailer tongue due south. Properly siting the trailer minimizes the travel of the solar array as it follows the sun, thereby minimizing the initial use of energy to orient the array.

Allow a minimum of 15 feet of free space from both sides and ends of GridPak and 35 feet of clearance above it. Fully deployed, the vertical height (mast and solar panels) of GridPak is 21 feet. It requires an unobstructed view of the rising/setting sun. The solar array will tilt and rotate throughout daylight hours.

- Ensure GridPak is close enough to load or input power to avoid having to reposition it
- Remove wheel chocks from the Accessory Storage cabinet
- With the GridPak suspended by the lifting device, but essentially on the ground, place wheel chocks against tires on both sides of the trailer

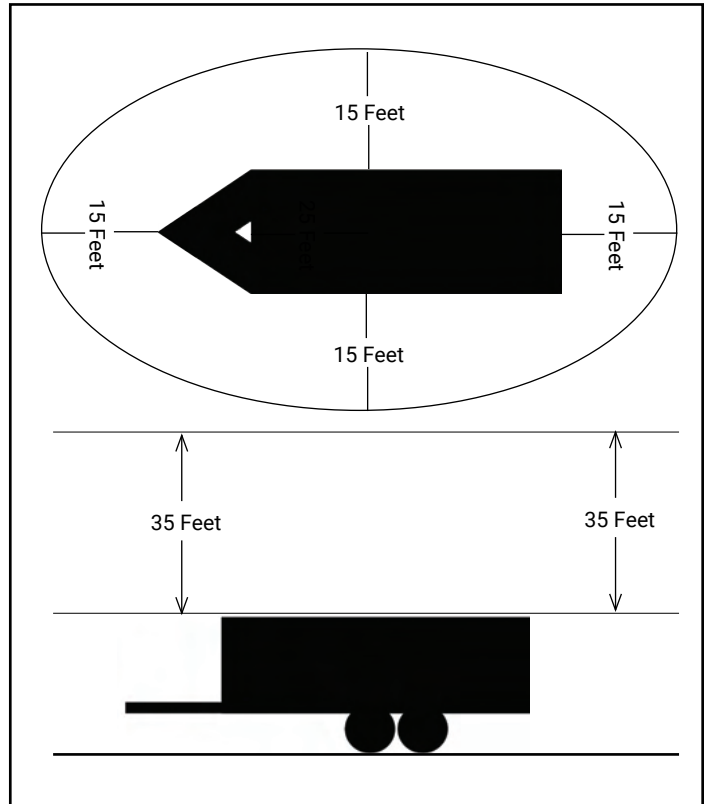

## 4.0 OPERATION

**⚠ CAUTION**

Keep hands and feet away from the foot of the trailer tongue jack as it travels up/down to avoid injury.

The GridPak trailer features an electrically-controlled hydraulic tongue jack to help lift the GridPak trailer off the tow vehicle hitch or otherwise clear the connection. The tongue jack control is mounted on the jack mast on top of the trailer tongue.



- Switch the on/off toggle switch on the hydraulic jack mast to "on" to provide illumination should it be needed to facilitate set up
- Toggle the rocker switch button down slightly to ensure GridPak will be roughly level, front to back, once fully lowered to the ground by the forklift or crane



This step helps facilitate a smooth and even deployment of the outriggers later in the process.

- Lower the GridPak fully to the ground
- Adjust the jack if necessary to help secure/stabilize it into a level position. Leave it at this height. It will help stabilize the GridPak when the outriggers are retracted and the trailer is returned to wheel-based support for transport or lifting

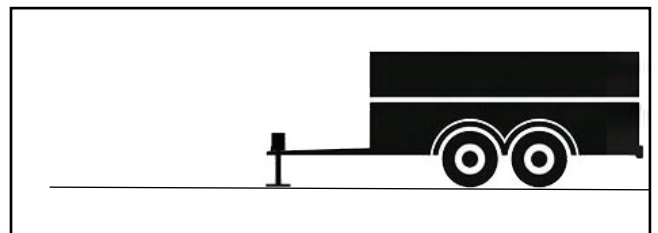

- Ensure wheel chocks are firmly in place



## 4.0 OPERATION

### 4.3.4 Setup Sequence

When the GridPak is appropriately sited, the trailer wheels chocked, and the tow vehicle or lifting devices secured and out of the way, it will be necessary to access the GridPak Operating System to continue deployment. Commands are entered on GridPak’s main control panel, which features an LCD touchscreen display and interface.

- Access the main control system panel at the back of GridPak by turning the key (supplied) in the cabinet lock. Swing the panel up to expose the control panel
- Wake up the GridPak display and operating system by tapping the display screen two-to-three times



The LCD display will activate and the last screen shown will appear.

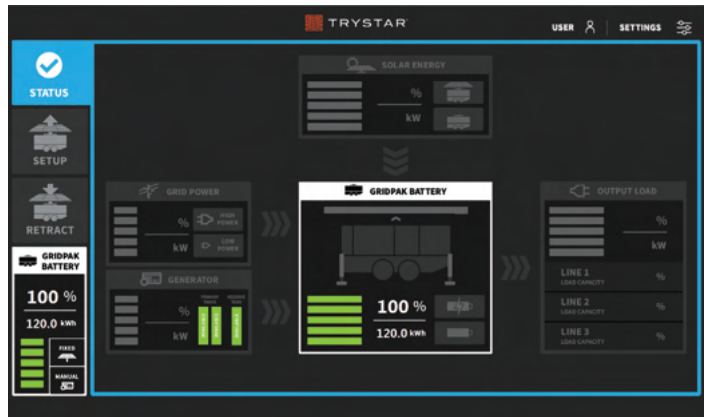

Three sets of lights are available to help illuminate the worksite, the cabinet controls, and the trailer. The exterior light switch controls the bright lights at the top edge of the sides and ends of the trailer. The auxiliary light switch activates the trailer running lights. The cabinet light switch helps illuminate the control and output panels to facilitate set up.



## 4.0 OPERATION

### 4.3.5 Prepare for Outrigger Deployment

- Touch the SETUP button to continue with the GridPak deployment process  
 Once you touch the SETUP button at left, a new status screen will appear and the SITE GRIDPAK button will light on the bottom bar. One of five directives/confirmations will appear on the screen. The directives are to ensure steps starting at **Section 4.3** have already been done. You will need to confirm each step by pressing the check box before being allowed to proceed with setup.
- Ensure the GridPak is on level ground and its sides primarily face East and West with the trailer tongue facing due south
- Press CONFIRM
- Ensure GridPak is close enough to service loads and/or receive input power
- Press CONFIRM

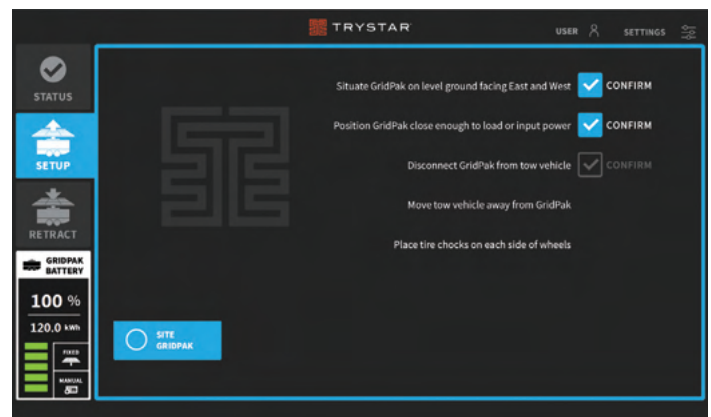
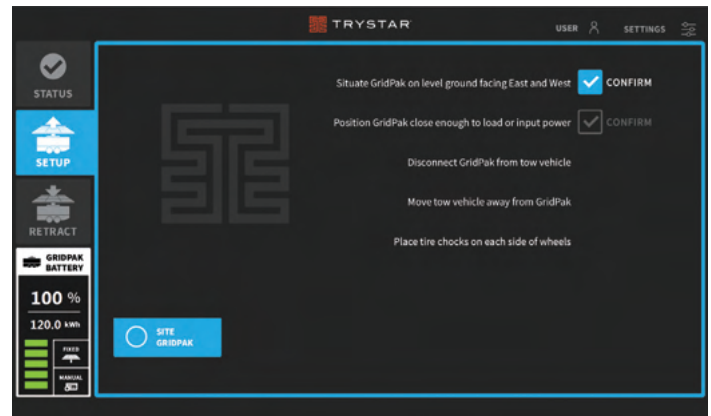
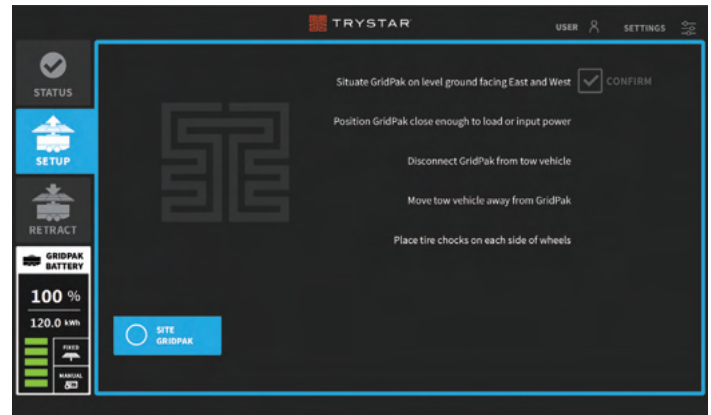

## 4.0 OPERATION

### 4.3.5 Prepare for Outrigger Deployment

- Ensure GridPak is disconnected from the tow vehicle
- Press CONFIRM

- Ensure the tow vehicle is moved away from GridPak
- Press CONFIRM

- Ensure the wheel chocks are placed firmly against the GridPak trailer tires, front and back
- Press CONFIRM

Once each step is CONFIRMED, the red Trystar logo will illuminate briefly and the SITE GRIDPAK button will be checked/completed.

Next, the DEPLOY OUTRIGGERS tab will automatically illuminate and the next one of six directives/confirmations will appear.

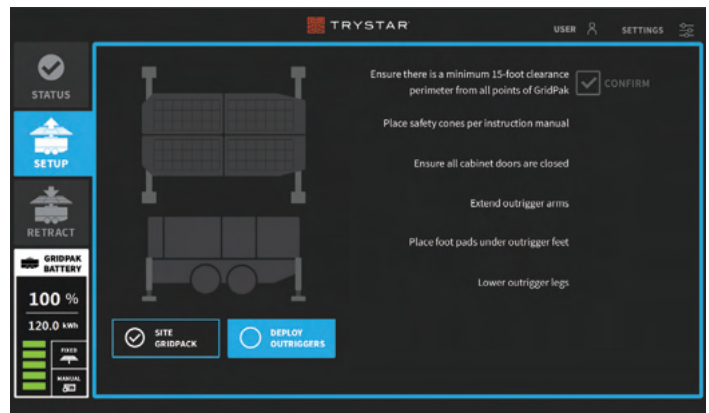
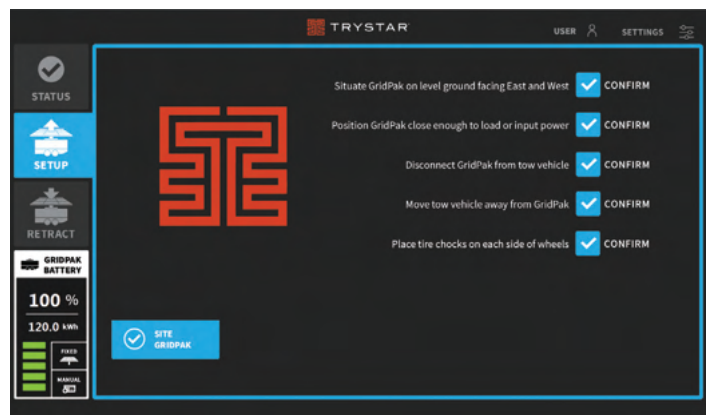
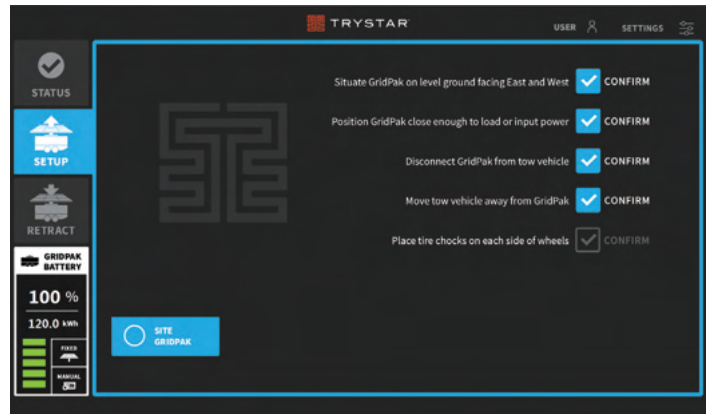
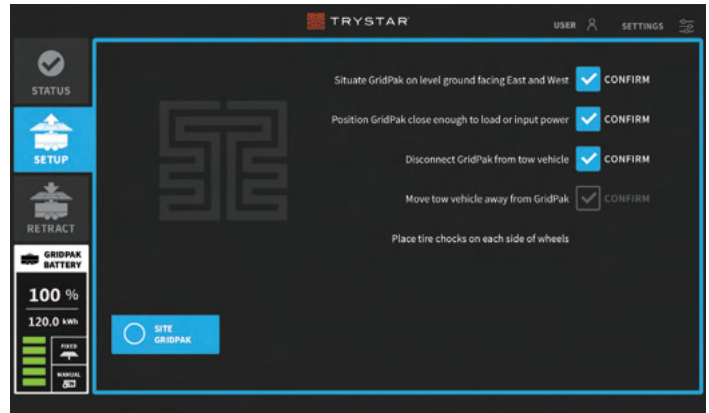

## 4.0 OPERATION

### 4.3.5 Prepare for Outrigger Deployment

The next set of steps cover deploying the GridPak outriggers. Each step will need to be CONFIRMED to proceed with outrigger deployment.

GridPak features four heavy-duty outriggers (one at each corner) that help level and secure it during operation. Before allowing you to proceed, GridPak will pose a number of directives/confirmations to which you must respond affirmatively. The directives/confirmations serve to remind you of certain steps you must complete for safe operation.

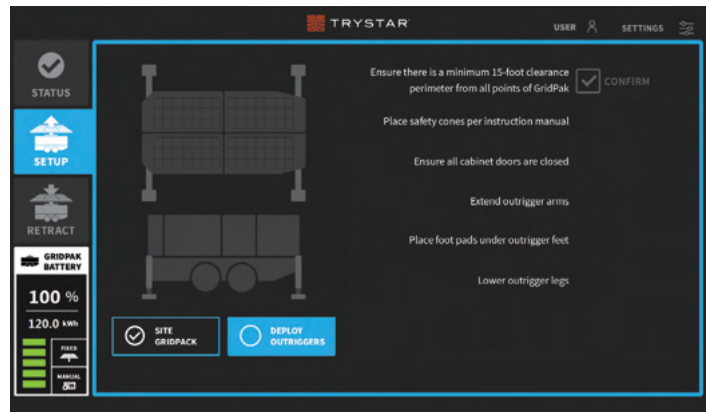

#### ⚠ WARNING

Operators should keep hands, feet, and other body parts away from the GridPak outriggers during deployment as they could cause severe personal injury or death. Operator(s) should ensure safety cones have been placed in a 15-foot perimeter around the GridPak and that no people or pets are within or allowed to enter within the 15-foot safety perimeter during deployment.

#### ⚠ CAUTION

GridPak's outriggers are deployed under significant force and can damage property. Make sure all GridPak equipment (e.g., cables) and other related equipment, including personal property, are well clear of the outriggers during deployment.

#### NOTICE

The GridPak outriggers are designed for placement on grass, dirt, gravel or other natural surface. The feet have cleats that will dig into a natural surface to help stabilize GridPak. If siting the GridPak on concrete, asphalt, or any other surface that is stable but otherwise could be damaged by the cleats, use the cleat foot pads which are in the Accessories Cabinet. Put one pad under each cleat before lowering the outriggers.

### 4.3.6 Deploy Outrigger Stabilization System

The outrigger deployment process has two parts: extend outrigger arms and lower outrigger legs.

The first question in the deployment process is whether the GridPak has proper clearance around it.

## 4.0 OPERATION

### 4.3.6 Deploy Outrigger Stabilization System

- Check to ensure there is at least 15 feet of space from sides/ends of GridPak
- Press CONFIRM

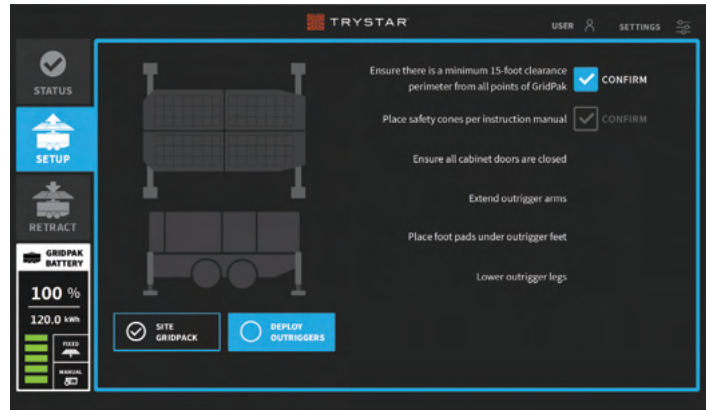

The second directive/confirmation prompts you to place the safety cones (located in the Accessory Cabinet) around the GridPak.

- Place safety cones around perimeter of GridPak
- Press CONFIRM

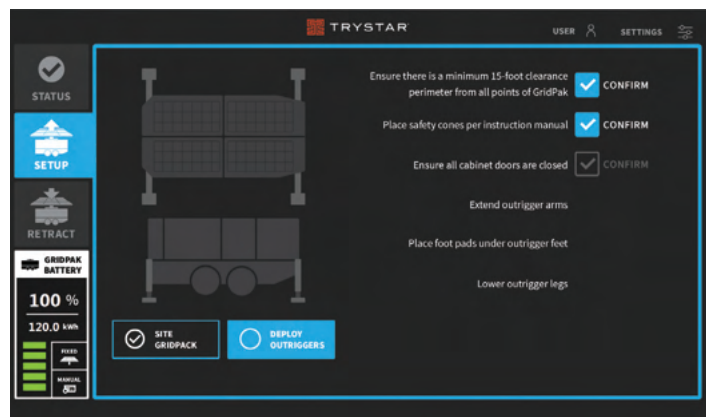

The third directive prompts you to close all cabinet doors which could be damaged during outrigger deployment. The control cabinet door may remain open.

- Close any other open cabinet doors on GridPak
- Press CONFIRM

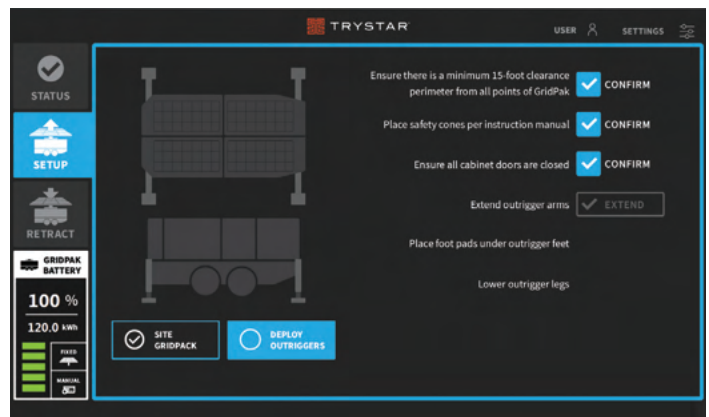

Once the first three directives are checked, the EXTEND button remains grayed out.

#### **⚠ WARNING**

The GridPak outriggers operate under extreme hydraulic pressure. Any objects underneath or in their path as they deploy could be crushed and/or damaged. Make sure there are no objects in and under the path of the deploying outriggers. Keep hands, feet and any other human extremities clear of the outriggers as they deploy as they can cause severe injury or death. Press any GridPak E-Stop button to stop their deployment in an emergency.

## 4.0 OPERATION

### 4.3.6 Deploy Outrigger Stabilization System

- Press the EXTEND check box on the LCD touchscreen to start the outrigger deployment

Once you press EXTEND, a warning tone and light will activate to caution operators (and any bystanders) to stay away from the outriggers. The hydraulic pump will also start and remain on until the outriggers and array are fully deployed. The directive/confirmation box will turn orange and change to "extending."

All four outriggers will automatically extend in preparation for lowering, one side at a time. The driver side will deploy first and then the passenger side.

Once extended, the warning tone and light will stop. The EXTEND button will change to green, be checked, and read "extended."

The fifth directive asks you to place the special foot pads under each outrigger foot when setting up on concrete, asphalt, or another hard but stable surface that could be damaged by the foot cleats. If setting up on a natural surface like dirt, grass, gravel or other, the foot pads may be unnecessary.

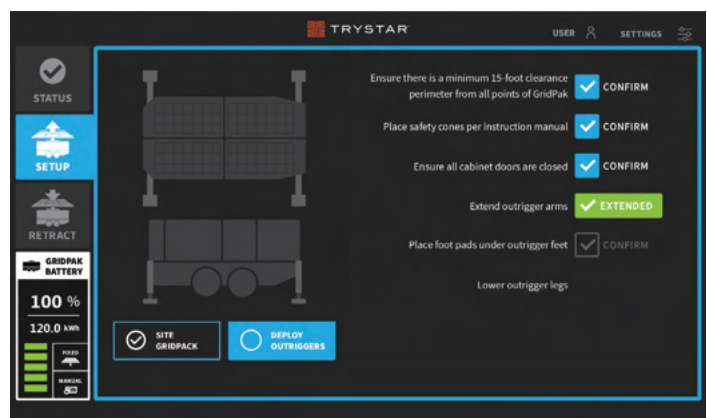
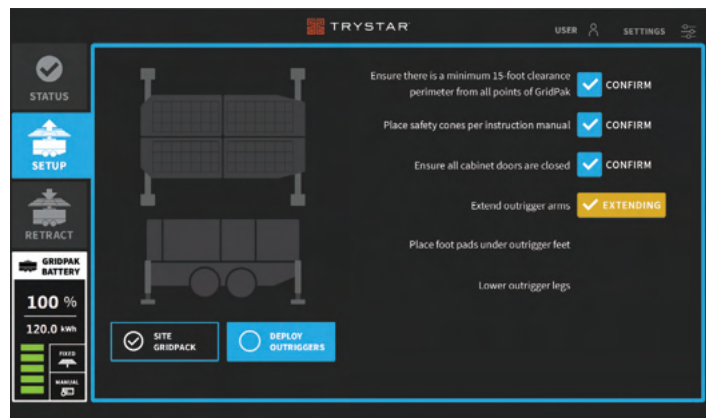
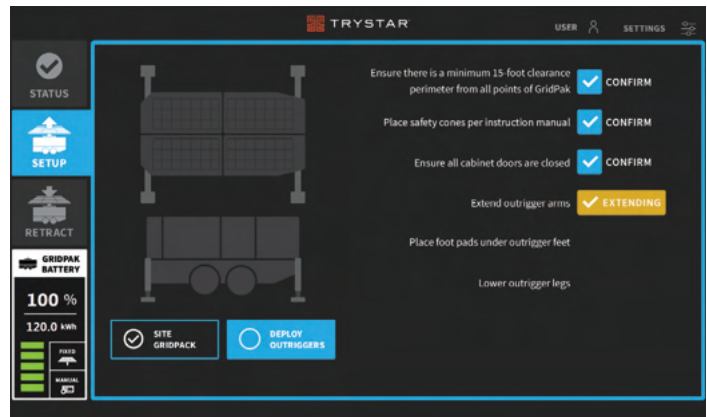

#### **⚠ WARNING**

The GridPak outriggers operate under extreme hydraulic pressure. Any objects underneath or in their path as they deploy could be crushed and/or damaged. Make sure there are no objects in and under the path of the deploying outriggers. Keep hands, feet and any other human extremities clear of the outriggers as they deploy as they can cause severe injury or death. Press any GridPak E-Stop button to stop their deployment in an emergency.

## 4.0 OPERATION

### 4.3.6 Deploy Outrigger Stabilization System

- Align and place footpads (if necessary) directly under the path of the outrigger cleat with the **orange bumper facing up**

- Press CONFIRM

Once the fifth directive (footpad) is confirmed, the box will illuminate and check mark appear. The LOWER command button will remain grayed out. You will need to press it to proceed.

- Press the LOWER command button

The light and tone will activate warning operators and any bystanders to remain clear of the outriggers. The directive/confirmation box will turn orange and change to LOWERING.

The outriggers will lower, one at a time, until approximately four inches above the ground (depending on how level the ground is). This interval allows the operator to adjust the placement of the cleat pads with greater accuracy. Once all legs have been lowered to this "spot check" position, all four will slowly descend in unison and level GridPak.

It is common for this operation to lift GridPak completely off the ground by several inches. This is normal and not a cause for concern. Once the legs are extended and lowered, the GridPak will self-level. Once leveled, the warning tone and light will stop. The LOWER button will change to green, the box will be checked, and the button will read, LOWERED. The legs in the side view of the GridPak graphic will illuminate and the DEPLOY OUTRIGGERS button will be checked and blue.

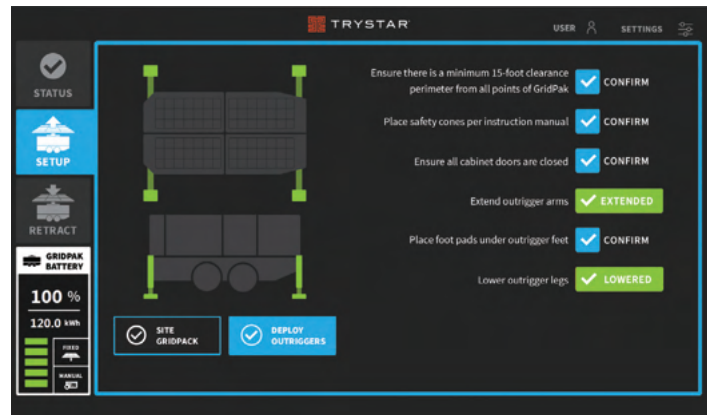
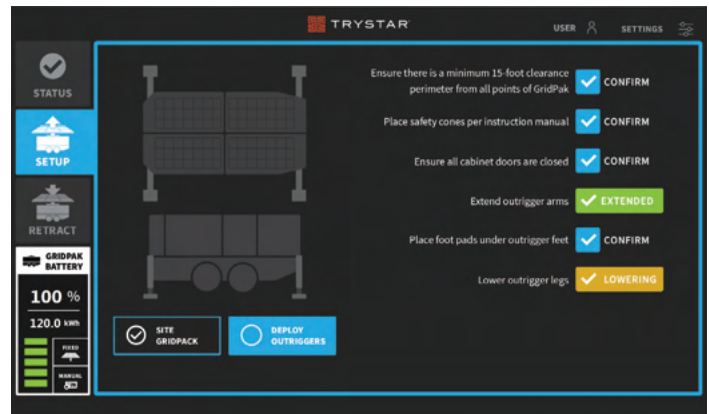
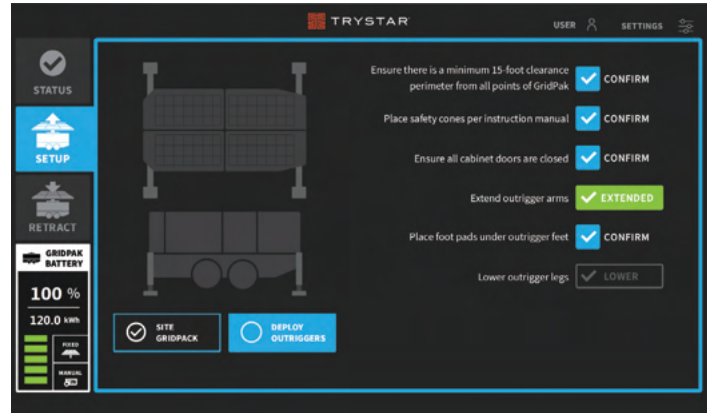

## 4.0 OPERATION

### 4.3.6 Deploy Outrigger Stabilization System

The self-leveling feature ensures GridPak is stable and ideally positioned to enhance solar array positioning. It also takes the weight off the trailer tires.

The next button on the lower command tab, DEPLOY SOLAR ARRAY, will now automatically illuminate, but not be checked, signaling it is the next step in the deployment sequence.

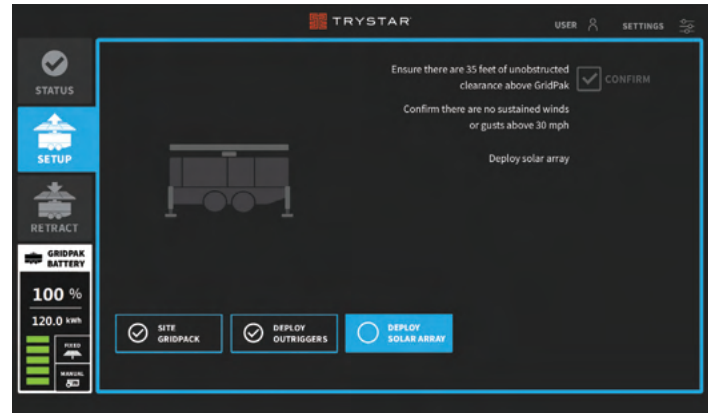

## 4.0 OPERATION

### 4.3.7 Preparing Solar Array for Deployment

**⚠ CAUTION**

To avoid damaging GridPak, it is important to ensure a minimum clearance of 35-feet from the top of the unit. Do not deploy GridPak in sustained winds higher than 30 MPH. Once deployed (in calm conditions) it can operate in winds up to 50 MPH.

Before deploying the solar array, it is necessary to ensure minimum obstacle clearances and wind speeds.

GridPak should be set up in mild conditions, i.e., no heavy sustained winds or gusts. It is designed to operate in heavy winds only when fully deployed. It is equipped with an onboard anemometer that will signal the array to flatten to a horizontal position parallel to the ground should winds approach 50 MPH.\*

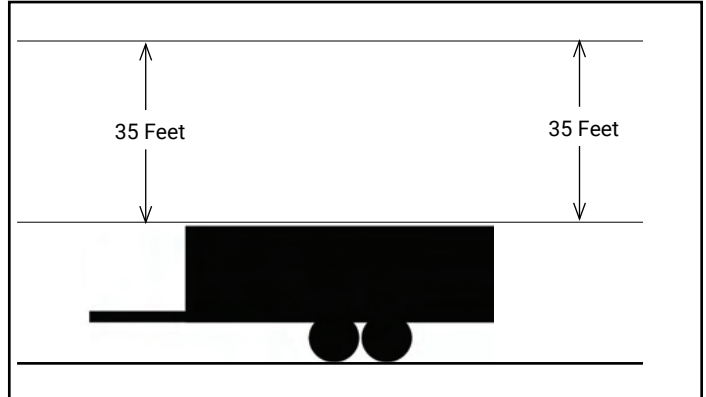

- Ensure there is 35 feet of unobstructed clearance above GridPak and that nothing will come in contact with the solar array from above at any angle, under any conditions
- Press CONFIRM once minimum space requirements are met

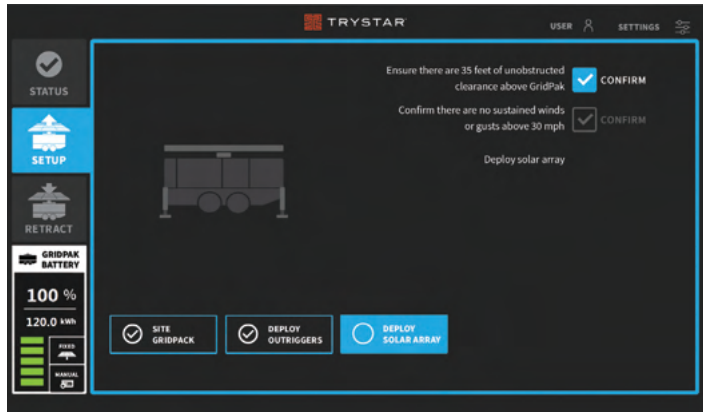

Using a hand-held anemometer to measure the wind speed is recommended. Ensure the wind speed and gusts do not exceed 30 MPH before pressing the confirm check box for this step.

- Press CONFIRM to validate acceptable wind speed

When the perimeter and wind requirements are met and confirmed, the DEPLOY SOLAR ARRAY directive/confirmation check box will remain grayed out.

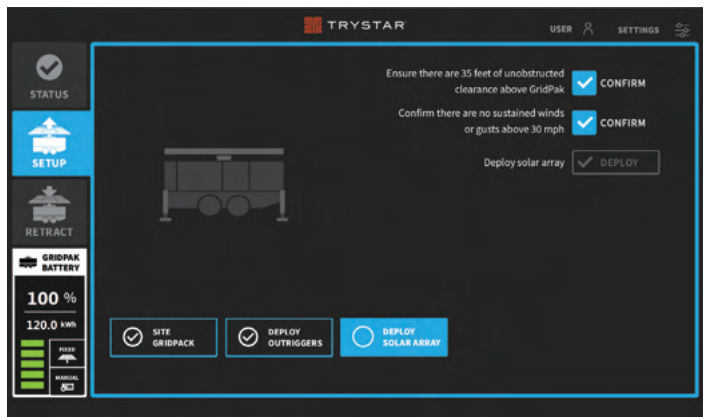

**\*Do not rely on the auto-flatten array feature. It is ultimately the responsibility of the operator to monitor wind speeds and weather in general to avoid damage to the GridPak. GridPak's array should be stowed and the GridPak protected in adverse conditions.**

## 4.0 OPERATION

### 4.3.8 Deploy Solar Mast and Array

**NOTICE**

To avoid damaging GridPak, make sure there are no objects resting on or near the solar panels and solar array. Do not deploy GridPak in inclement weather, i.e., high winds or hail, etc.

- Press the DEPLOY SOLAR ARRAY check box on the right side of the display panel to initiate the deployment process

The hydraulic pump (already on) will engage and the solar array and weather tower will now start the deployment process. The directive/confirmation check box will turn orange and change to DEPLOYING.

During deployment, the mast will raise and the solar panels will unfold to a horizontal position. It will take several seconds for the solar array to deploy, after which the hydraulic pump will stop.

The DEPLOY solar array directive/confirmation check box will turn green, be checked, and read, DEPLOYED. The array is now capable of charging the batteries. The DEPLOY SOLAR ARRAY button will be checked and blue.

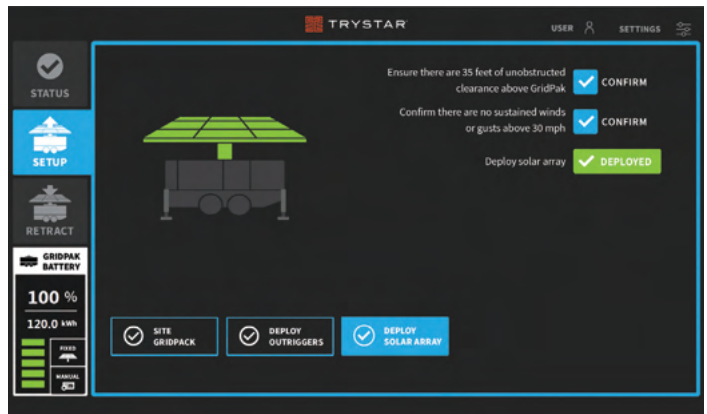
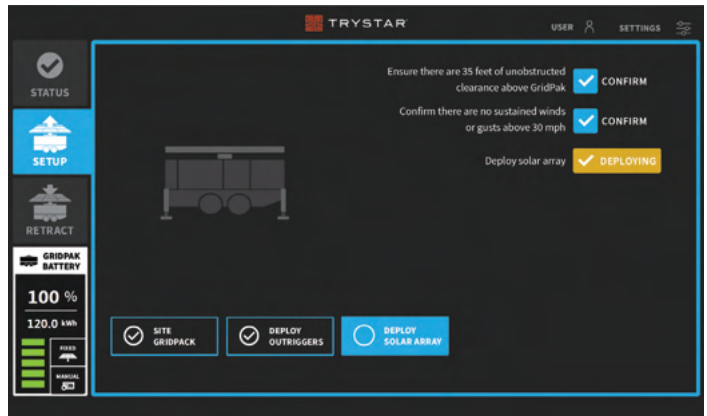

### 4.3.9 Enable or Skip GPS Solar Array Tracking

The next input screen and the solar tracking, button will now appear signaling the next step in the process. This step represents an extra precaution to protect the solar array from damage and to offer additional program flexibility. A new screen will appear with either one or two directive/confirmation check boxes.

The first directive is associated with the choice to enable solar panel GPS tracking. It queries whether the solar array is free to rotate and tilt (without hitting obstructions) while tracking the sun, using the onboard GPS system.

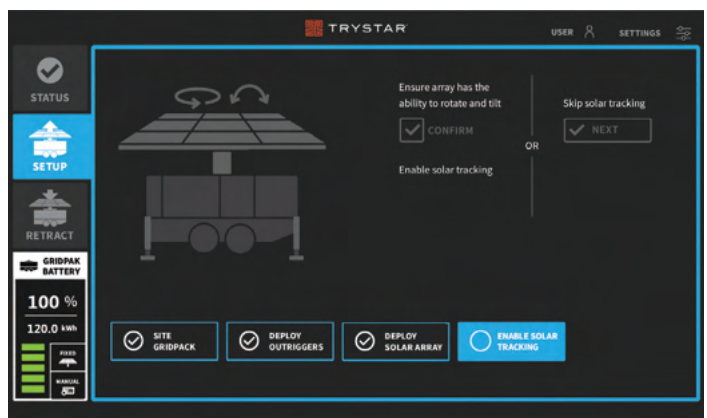

## 4.0 OPERATION

### 4.3.9 Enable or Skip GPS Solar Array Tracking

The GPS automatically finds and tracks the sun throughout the day, regardless of GridPak’s geographic location. By CONFIRMING the ENABLE SOLAR TRACKING directive, the GPS will be engaged and the solar array will continuously orient itself to the sun. Trystar recommends using solar tracking to optimize energy collection.

Alternatively, you can choose to SKIP SOLAR TRACKING and proceed to the next step in the deployment process. This choice still leverages solar charging but the solar array will remain stationary in the raised horizontal position.

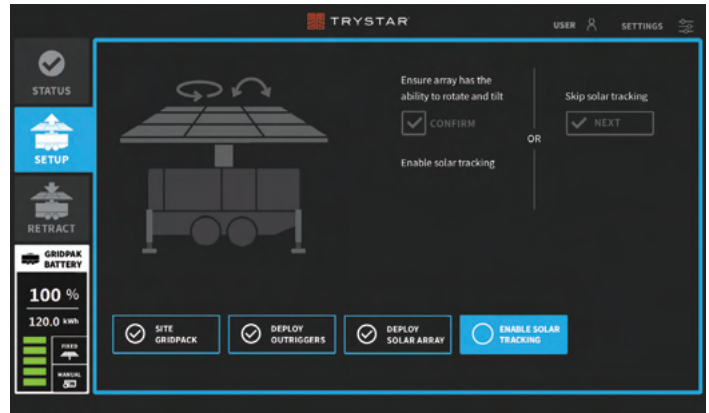

#### 4.3.9.1 Enable GPS Solar Array Tracking

If you choose to enable the solar panel GPS tracking feature, it is necessary to ensure there are no obstructions (e.g., trees, wires, etc.) that could impede its ability to rotate and tilt. Keep 35 feet of unobstructed space available above the GridPak and surrounding the array.

- Press CONFIRM to validate free-space

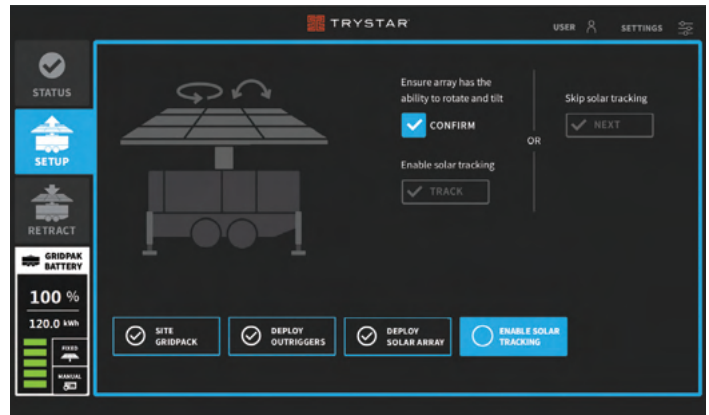

Next, you will need to press the TRACK directive/confirmation box to enable solar panel GPS tracking.

- Press TRACK to enable solar tracking

The TRACK directive/confirmation box will turn green and the confirmation button will change to TRACKING. The ENABLE SOLAR TRACKING button will be checked and blue.

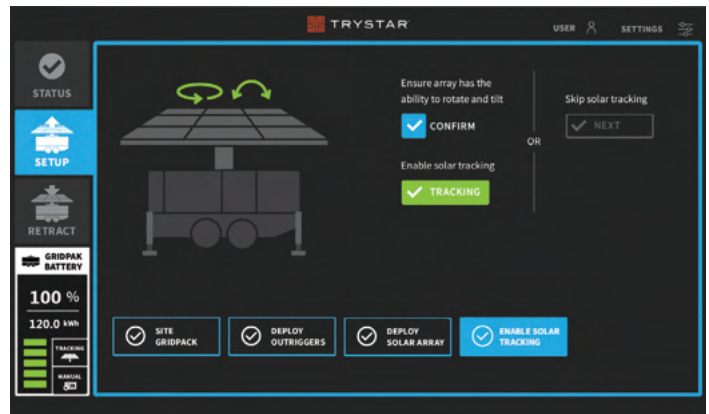

**NOTE:** If for some reason (e.g., it cannot find at least three satellites) the GridPak cannot provide solar tracking, the TRACK button will revert to gray after being pressed. Check NEXT in the Skip Solar Tracking field to proceed with set up.

## 4.0 OPERATION

### 4.3.9.1 Enable GPS Solar Array Tracking

Once solar tracking is enabled, the next setup screen will reveal a graphic of the GridPak's Operating System and receptacle panel. The SOLAR TRACKING button will be checked and the POWER LOADS button at bottom will illuminate but remain unchecked. A new set of directives/confirmations will also appear signaling the next step in the process.

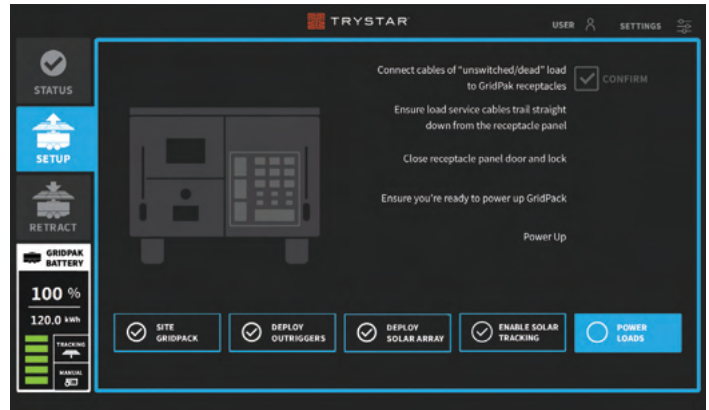

### 4.3.9.2 Skip GPS Solar Array Tracking

GridPak allows the option of simply deploying its solar array panels without enabling solar panel GPS tracking.

- Press the NEXT directive/confirmation check box to skip GPS tracking  
Confirming NEXT bypasses solar tracking. The SOLAR TRACKING button at bottom will be checked indicating this step in the process has been addressed.

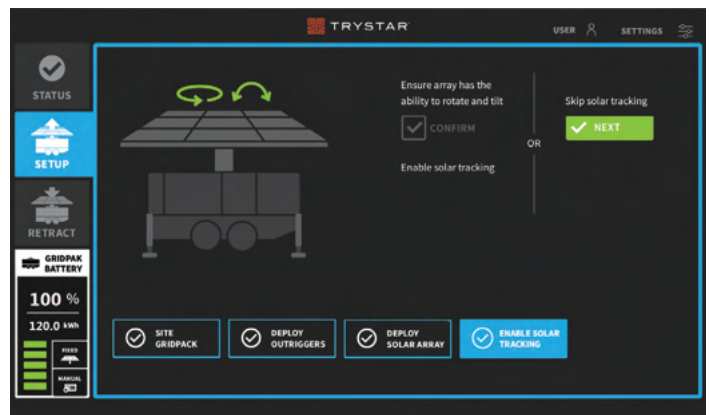
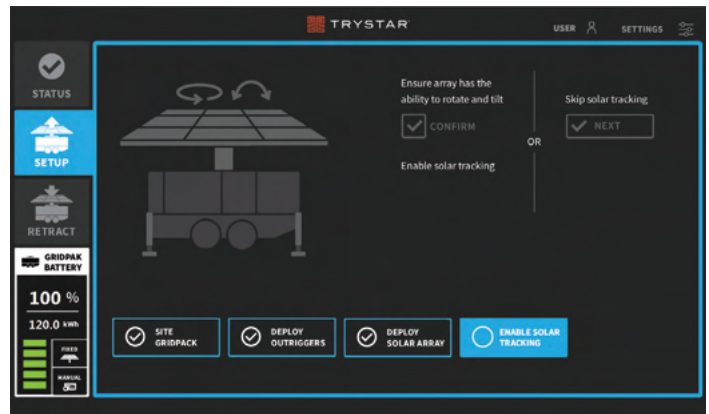

The next setup screen will automatically appear with a new set of directives/confirmations signaling the next step in the process. It will reveal a graphic of the GridPak's Operating System and receptacle panel. The enable solar tracking button at bottom will be checked and the POWER LOADS button at bottom will illuminate but remain unchecked.

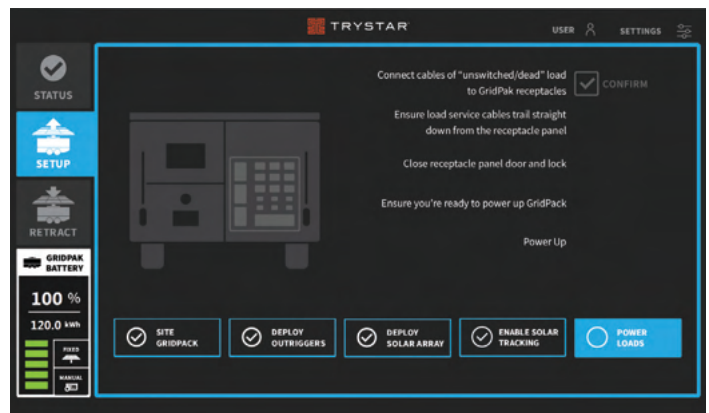

## 4.0 OPERATION

### 4.3.10 Power Loads

Prior to deploying the GridPak, it is important to consider the type of loads it will power and their respective or aggregate power draw. Some rough calculations allow insight into operational considerations. Alternatively, power calculation tools are widely available on the Web and will help with deployment planning.

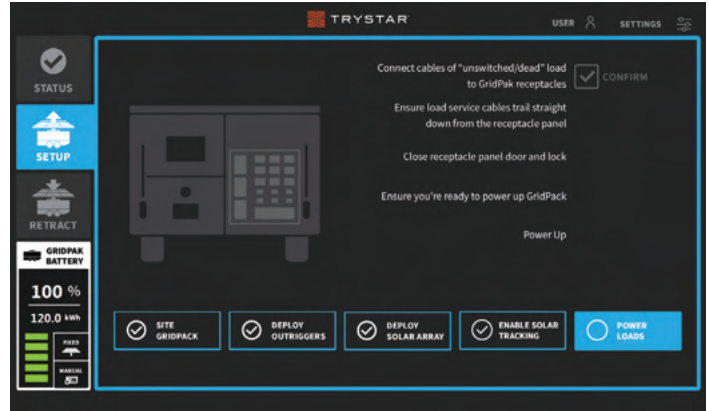

The sustainability value of GridPak is maximized when it can bear electric loads using solar and battery power alone. It is important to gauge the performance and response of GridPak to the current draw of the powered devices once it has been deployed by observing the Status screens on the LCD.

A primary goal is to ensure GridPak can cover the aggregate loads fully using its current battery charge and the adequate restoration of that charge via the solar array. Should the solar array be unable to collect the energy needed to meet adequate restoration of the batteries (<5 kW), it will be necessary to supplement solar array charging using the ancillary generator.

The total load of the devices you plan to power with GridPak must be considered in terms of total wattage in advance. (A web-based wattage calculator [showing watts, amps, voltage, and ohms] is useful for load planning.) Typically, the devices needing power will have an information plate or label that provides a wattage rating. For example, a 100-watt light bulb in a 120-volt system, lit for 10 hours, consumes 1 kWh.

GridPak is configured for large loads, expressed in thousands of watts (kilowatts or kW) being drawn concurrently over a period – in this case, hours. The number of 1000-watt units available in an hour are expressed on the GridPak status screens as kWh or number of kilowatt hours. A kWh is a measure of how long a 1 kW load could be sustained. The GridPak 120 Model has enough energy to supply a 1 kW load for 120 hours (1 kW x 120 hr. = 120 kWh). If GridPak was powering a 24 kW load (the maximum of the three-inverter model), it has enough energy for five hours (24 kW x 5 hr. = 120 kWh).

#### ⚠ CAUTION

To avoid damaging GridPak or connected loads, make sure the connected loads do not exceed the capacity of GridPak by calculating startup and sustained loads in advance. Make sure loads are switched off at their source before connecting them to the GridPak.

#### ⚠ CAUTION

The ground cable should always be the first cable connected and the last cable disconnected to avoid a short, electrical damage, sparks and other conditions which may harm the operator.

## 4.0 OPERATION

### 4.3.10 Power Loads

A GridPak is configured according to customer needs and anticipated loads. Standard or specialized electrical receptacles are located next to the main control panel at the back of the GridPak.



Regardless of whether SOLAR TRACKING is engaged or not, the GridPak Operating System will now ask you to confirm the sequence for powering up GridPak and connecting loads. A new set of directives/ confirmations will appear. The loads must be unswitched/dead before connecting them to the GridPak.

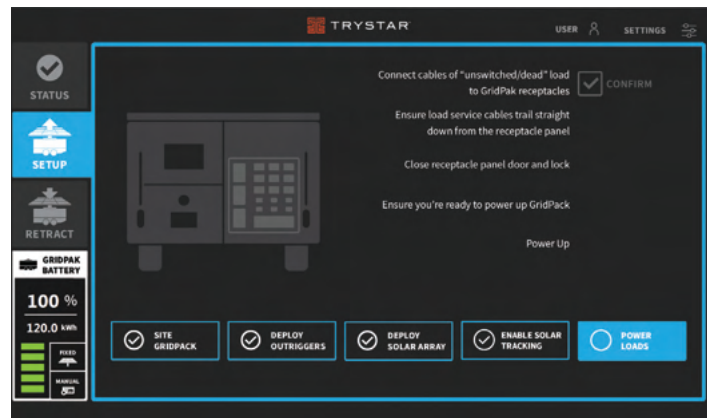

To prevent tampering and cable theft, the GridPak is equipped with a trap door behind the bumper and below the connection panel as shown in the adjacent image. Unfasten the two trap door latches under the panel and run the cables from the connected loads up through the trap door before making connections. The cables and connections will be protected once the cabinet door is closed and locked.



## 4.0 OPERATION

### 4.3.10.1 Connect Unswitched/Dead Loads

- Connect unswitched/dead loads to the appropriate receptacles on the GridPak and press CONFIRM

The check box for the first step will illuminate.

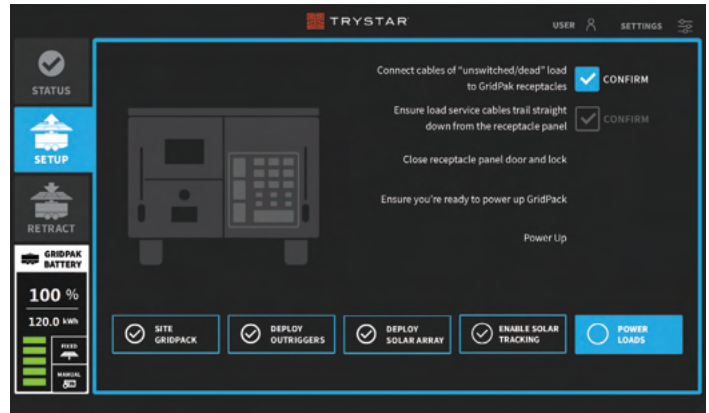

### 4.3.10.2 Drape Load Service Cables

- Ensure all cables are draped neatly from the receptacle panel and down through the trap door and press CONFIRM

The third directive/confirmation check box will now appear, signaling the next step which is to close and lock the receptacle panel door.

- Close the GridPak breakers that will carry loads

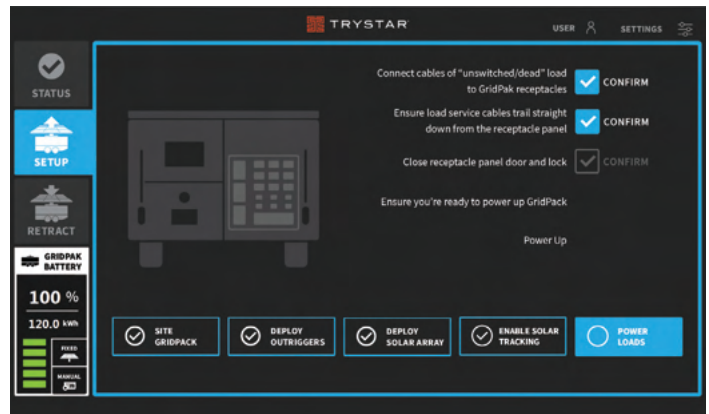

### 4.3.10.3 Close Power Cable Receptacle Door

- Close and latch power cable receptacle door and press CONFIRM

The check box will turn blue confirming the panel door is closed.

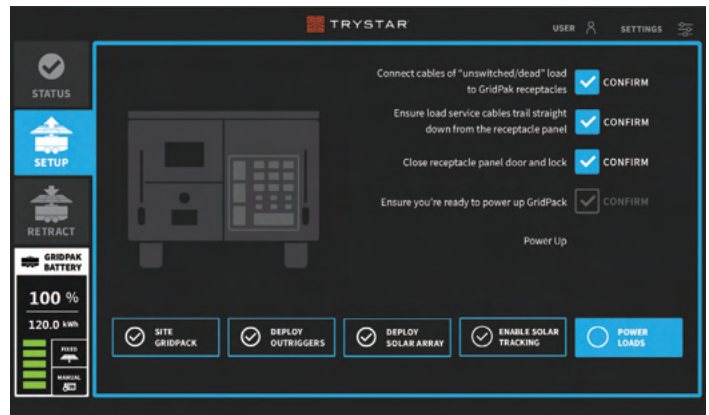

### 4.3.10.4 Ensure Preparedness to Power Up the GridPak

With the unswitched/dead loads connected to GridPak and the cables draped neatly (not overlapped or twisted) through the trap door, and the receptacle door closed, the next step is to conduct a final safety check and inspection of the GridPak. Conduct a final check of the GridPak site and peruse all the safety notices to make sure everything is in order before proceeding to the final steps.

## 4.0 OPERATION

### 4.3.10.4 Ensure Preparedness to Power Up the GridPak

- Press CONFIRM to indicate readiness to power up GridPak

Once the safety check and inspection are completed, the directive/confirmation check box for that step will be checked and illuminated, signaling the last step in the deployment process.

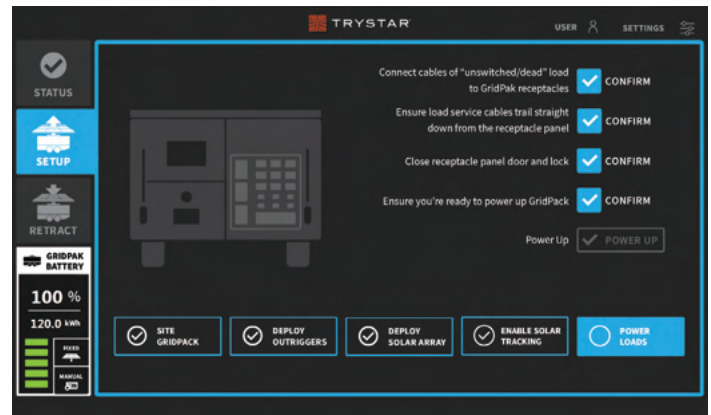

### 4.3.10.5 Power Up GridPak

- Press the POWER UP directive/confirmation check box to power up the GridPak.

The POWER UP button will turn green and convert to POWERED and the POWER LOADS tab will turn blue and be checked. A lightning bolt symbol will appear over the receptacle panel on the GridPak graphic image. You may hear a loud knock which is the main contactor closing. The receptacle door safety interlock will also automatically lock the cabinet door.

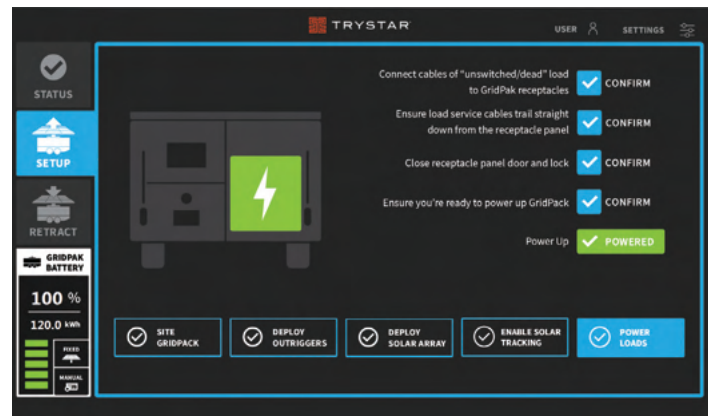

GridPak is now ready to power loads. The system will automatically bring up the STATUS screen.

Powering up the GridPak enables GridPak to charge its batteries, monitor conditions, and shift from battery power to backup power generation (LP generator) as dictated by environmental conditions and power demands.

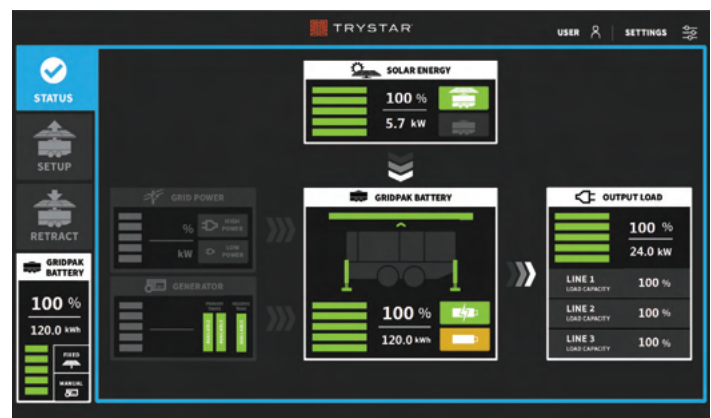

It is now possible to energize the loads at their source and then monitor GridPak operation.

## 4.0 OPERATION

---

### 4.3.10.6 Switch On Loads at Source

- Energize the loads at their source one at a time
- Wait for GridPak to display a load before energizing the next load
- Observe any alerts and follow Operation System prompts as necessary

The next section of this GridPak Operating Manual details the status screens and associated interpretation of the data.

## 4.0 OPERATION

### 4.4 Operating GridPak

The sustainability value of GridPak is maximized when it can bear electric loads using solar and battery power alone. It is important to gauge the performance and response of GridPak to the current draw of the powered devices once it has been deployed by observing the Status screens on the LCD.

A primary goal is to ensure GridPak can cover the aggregate loads fully using its current battery charge and the adequate restoration of that charge via the solar array. Should the solar array be unable to collect the energy needed to meet adequate restoration of the batteries (<5 kW), it will be necessary to supplement solar array charging using the ancillary generator.

The total load of the devices you plan to power with GridPak must be considered in terms of total wattage in advance. (A web-based wattage calculator [showing watts, amps, voltage, and ohms] is useful for load planning.) Typically, the devices needing power will have an information plate or label that provides a wattage rating. For example, a 100-watt light bulb in a 120-volt system, lit for 10 hours, consumes 1 kWh.

GridPak is configured for large loads, expressed in thousands of watts (kilowatts or kW) being drawn concurrently over a period – in this case, hours. The number of 1000-watt units available in an hour are expressed on the GridPak status screens as kWh or number of kilowatt hours. A kWh is a measure of how long a 1 kW load could be sustained. The GridPak 120 Model has enough energy to supply a 1 kW load for 120 hours (1 kW x 120 hr. = 120 kWh. If GridPak was powering a 24 kW load (the maximum of the three-inverter model), it has enough energy for five hours (24 kW x 5 hr. = 120 kWh).

#### NOTICE

Prior to deployment, the operator should ensure that the GridPak can accommodate the total planned load at the site. It is recommended that the equipment requiring power be evaluated, in aggregate, in terms of wattage, voltage, and amperage. See **Section 3.2** in this manual.

#### NOTICE

GridPak can use three different charging sources. When it is being prepped for transit to a worksite, the GridPak should be fully charged. The fastest method is via the grid. GridPak can also be charged via the grid when deployed as well. The primary method of charging the GridPak is via its solar array. The backup generator set can provide supplementary charging if conditions preclude adequate exposure to sunlight.

#### 4.4.1 Operating Status

GridPak incorporates a color LCD touchscreen as part of its Operating System. It is central to controlling deployment and retraction via a set of commands and command directives/confirmations. It is also used to observe various conditions and status as the GridPak operates. It can advise the operator about the amperage of the various individual and aggregate loads, indicate battery status and remaining kWh available, show empty LP tanks, denote the solar charge yield and much more. The GridPak operating system default is to show battery power metrics, regardless of what screen the operator may wish to view. The following discusses some of the status metrics in detail.

## 4.0 OPERATION

### 4.4.2 Battery Energy Level

The battery level meter is one of the most important status screens. It tells you how many kilowatt hours (kWh) of energy remain to power the aggregate load. It also shows the current battery level expressed as a percentage.

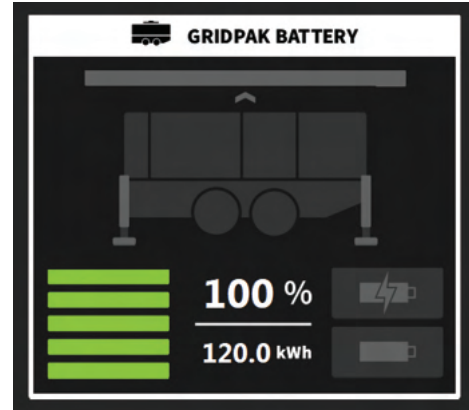

### 4.4.3 Output Load

The output load meter is also important because it denotes the power draw on the batteries. It is also expressed in kW. If considered together, the battery level and output load could tell you how many hours the batteries could power the load without being charged. It provides an intuitive understanding of charge relative to draw. It is possible to pull the full 24 kW (max. load subject to change) load from the batteries independent of input power.

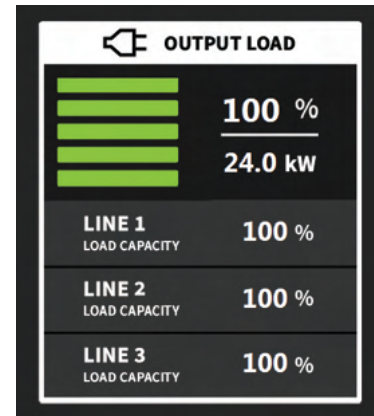

### 4.4.4 Grid Power

The three remaining status metrics indicate how GridPak is being charged and at what level. GridPak batteries can be charged from the main grid. When this is the case, the Grid Power meter is illuminated, and the grid icon will show. The display will show the rate at which the batteries are being charged in kW.

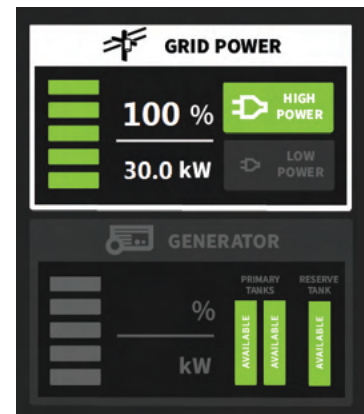

## 4.0 OPERATION

### 4.4.5 Generator Power

When the GridPak batteries are being charged via its onboard generator, the Generator Power display and icon are illuminated. The graphics will show at what rate the GridPak batteries are being charged.

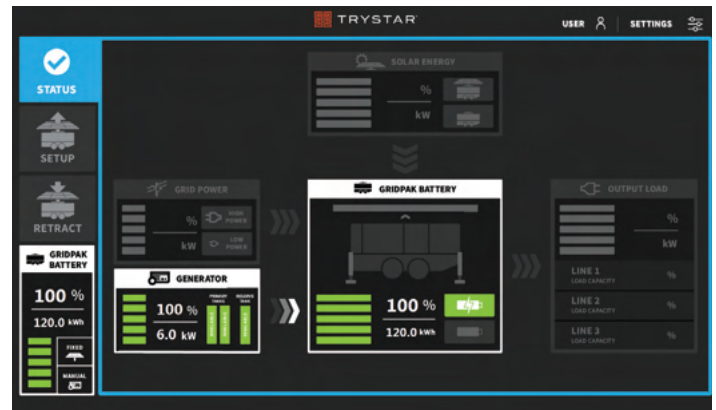

### 4.4.6 Solar Energy

In most cases, the Solar Energy display and icon will be illuminated, along with the Battery Energy Level and Output Load meter displays. The Solar Energy display will show the rate at which the batteries are being charged in terms of kW. At any point in time, it will be possible to tell whether the solar charging is keeping the batteries adequately charged so the electrical load can be handled without interruption or intervention (e.g., the backup generator powers up to supplement solar charging).

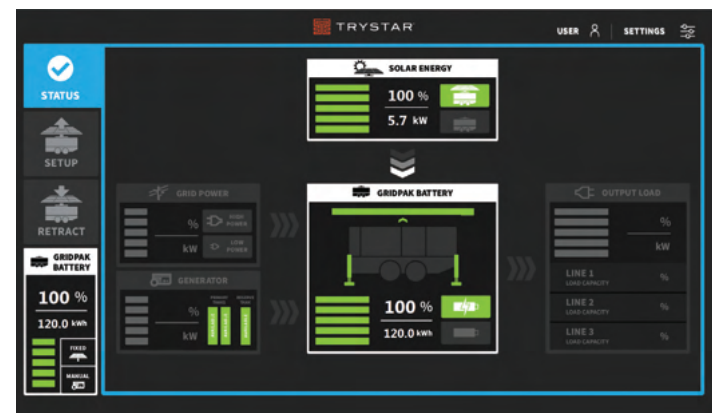

## 4.0 OPERATION

---

### 4.4.7 Charging GridPak

There are four different means to charge the GridPak. The primary method is via the solar array. The onboard backup generator can also be used to charge the Gridpak. Finally, it can be charged by three-phase or single-phase utility power. GridPak can be charged by the solar array in tandem with only one of the other methods.

GridPak has a switch by which to choose between high- and low-input shore power charging. High-input shore power requires a three-phase cam-lock input connection and can charge GridPak at ~30 kW. A low-input shore power connection is the equivalent of a standard 120 volt wall outlet and can charge at 2.0 kW.

Utility power is the ideal method of charging when GridPak is being stored and should be used whether or not GridPak needs charging when temperatures are below freezing.

When onsite, solar power is the ideal method for charging GridPak with the generator being available as a backup. The generator provides a maximum of ~ 6.5 kW and solar a maximum of ~ 5.7 kW.

## 4.0 OPERATION

### 4.5 Powering Down GridPak

#### ⚠ WARNING

Hot exhaust parts (e.g., backup LP-fueled generator) can cause severe burns. Energized cables can cause electric shocks, moderate or severe injury, and death. Make sure all protective guards, safety devices, and enclosures are properly in place before starting or working on or around GridPak and connected loads. Wear appropriate personal protective equipment (PPE).

#### ⚠ WARNING

Cables between GridPak and energized loads pose tripping hazards as well as potential for electrical shocks, including minor and major injuries, or death. Approach connecting points and cables with caution. Wear appropriate personal protective equipment (PPE) when working with cables and connected loads.

The process and sequence of steps to power GridPak down and prepare it for transit to the next project or other destinations are basically the reverse of its deployment – with some exceptions. Approach the GridPak cautiously, observing the outrigger and load cable locations to avoid tripping or possible electrical shocks.

#### NOTICE

Make sure all devices drawing power from GridPak are powered down at their source and at the GridPak breaker panel before disconnecting their load supply cables from GridPak.

#### 4.5.1 Power Down Connected Loads

The GridPak requires a retract/power down sequence designed to protect it as well as connected loads.

- Press the RETRACT command button at left on the LCD panel
- Turn off all loads connected to GridPak at their source
- Switch off the GridPak breakers for each load

To ensure all loads are powered down at their source and at the breaker, it is possible to pause the retraction process and press the STATUS button. The Output Load meter should register zero kW.

- Press the STATUS command to ensure there is no power draw on GridPak from connected loads

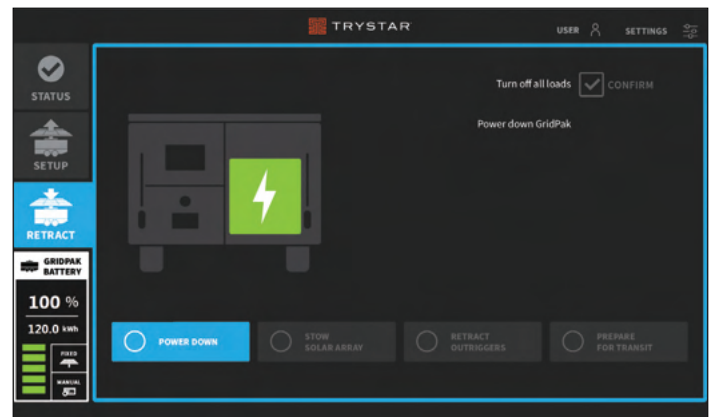

## 4.0 OPERATION

### 4.5.1 Power Down Connected Loads

Once loads are confirmed powered down at their sources, return to the RETRACT screen to proceed with the process by confirming there are no powered loads.

- Press the RETRACT command in the left tab
- Press the CONFIRM check box to indicate all loads are powered down

The POWER DOWN tab at bottom will be illuminated but unchecked. The Operating System will continue to recognize changing status and modes and reflect that information in the bottom tab.

### 4.5.2 Power Down GridPak

To power down GridPak, it will be necessary to confirm the action.

- Press the POWER DOWN check box to power GridPak down

You may hear a loud knock when powering down GridPak which corresponds to the main contactor opening. The POWER DOWN check box will change to green and read POWERED DOWN.

A check mark will now appear in the POWER DOWN button at bottom. The Power Down GridPak check box will change to green and read POWERED DOWN. The next set of directives/confirmations in the retraction process will automatically appear in the next screen and the button for RETRACT SOLAR ARRAY will illuminate.

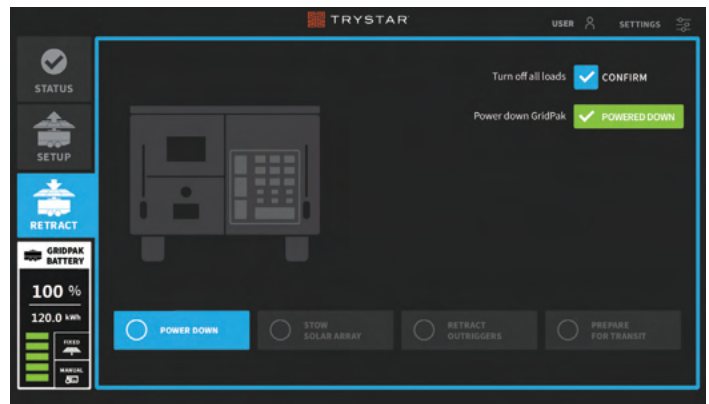
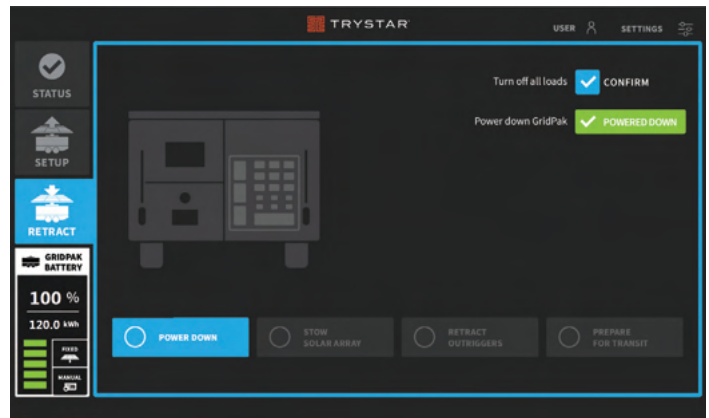
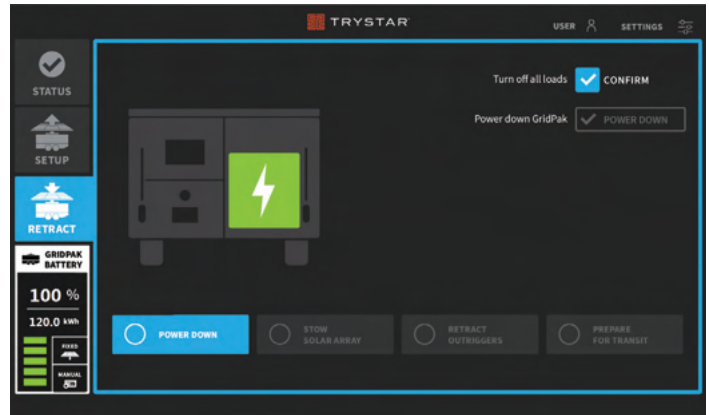

## 4.0 OPERATION

### 4.5.3 Retract Solar Array

**⚠ CAUTION**

To avoid damaging solar mast, panels or array mechanisms, ensure there are no obstructions (tools, cable, twigs, debris, etc.) that could impede the mast and array from stowing properly.

To initiate the solar array retraction, it is important to ensure no tools, cables, vegetation, or other obstructions or obstacles are under or on top of the solar array. Closing the array on debris or other objects can cause damage to the array and the related mechanism. It is also important to disconnect load cables from the receptacle panel and make sure all cabinet doors are closed and locked. The system will step through the process.

- Disconnect all load cables from the GridPak receptacle panel
- Press CONFIRM
  
- Close and lock GridPak receptacle panel as well as any other open panels
- Press CONFIRM
  
- Ensure there are no objects/obstacles that would damage and/or prevent solar array from rotating and retracting
- Press CONFIRM

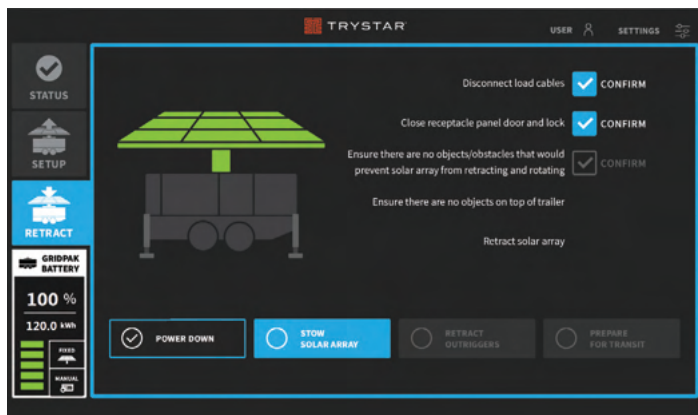
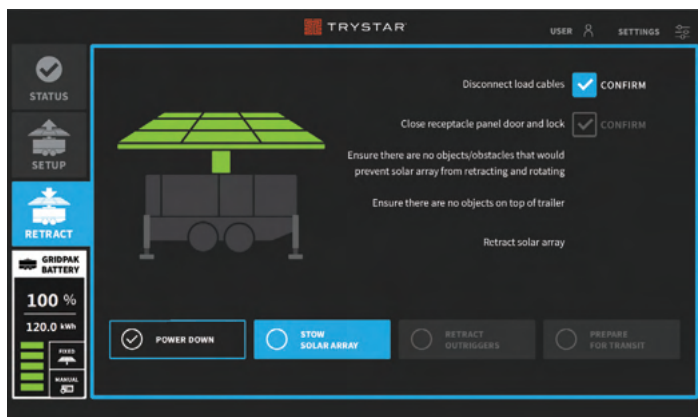
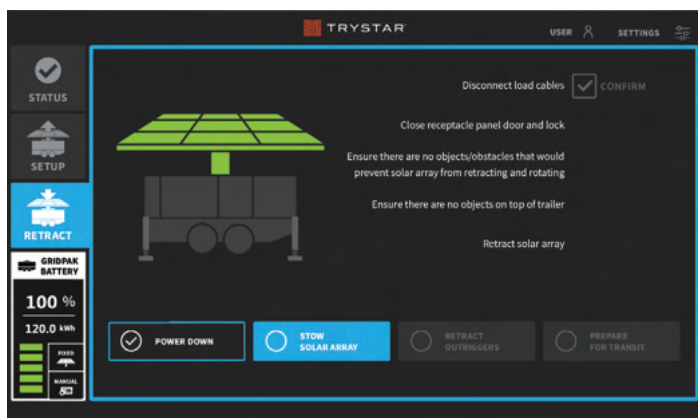

## 4.0 OPERATION

### 4.5.3 Retract Solar Array

- Ensure there are no objects/obstacles on top of the trailer
- Press CONFIRM

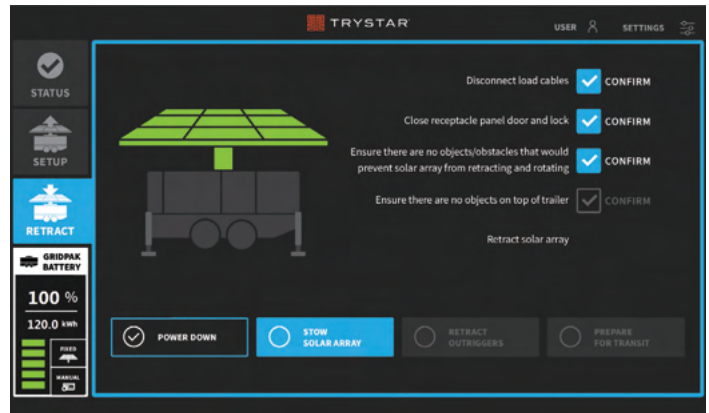

Once the four preparatory directive/confirmation check boxes are CONFIRMED to ensure no obstacles will impede or damage the array or trailer top, you can proceed to full retraction.

- Press the RETRACT check box

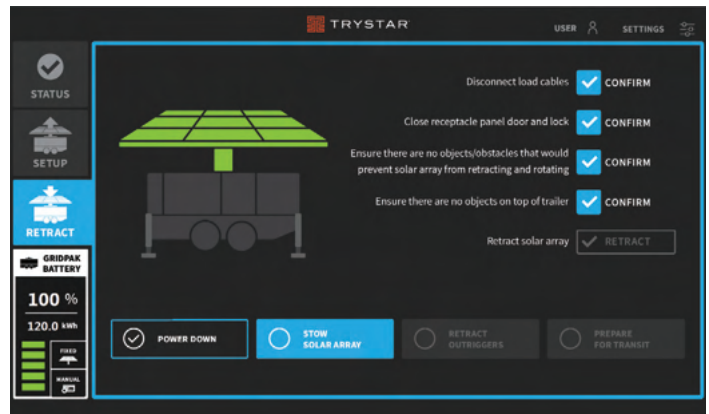

The Trystar GridPak solar array will automatically pivot and align with the trailer. Next you will hear the hydraulic pump spin up and pressurize the system. The array will fold and drop. This process will take several seconds. The RETRACT check box will change to orange and convert to RETRACTING during the process. The hydraulic pump will continue to operate until the outriggers are stowed at which point it will shut off.

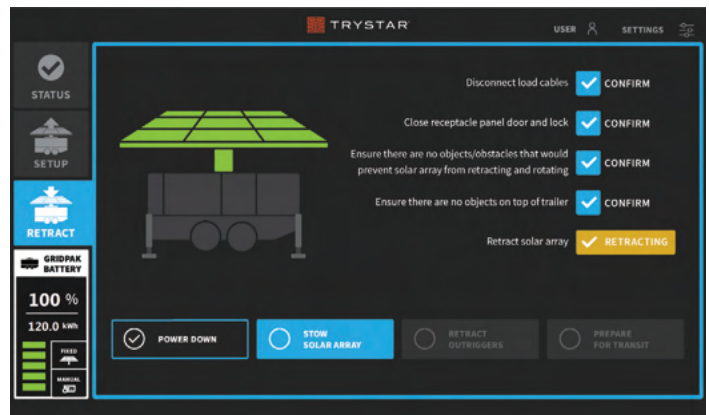

The display panel will indicate the completion of the retraction cycle by changing to green and by converting the RETRACT check box to RETRACTED status with a corresponding check mark. The RETRACT SOLAR ARRAY button at the bottom of the display will also be checked.

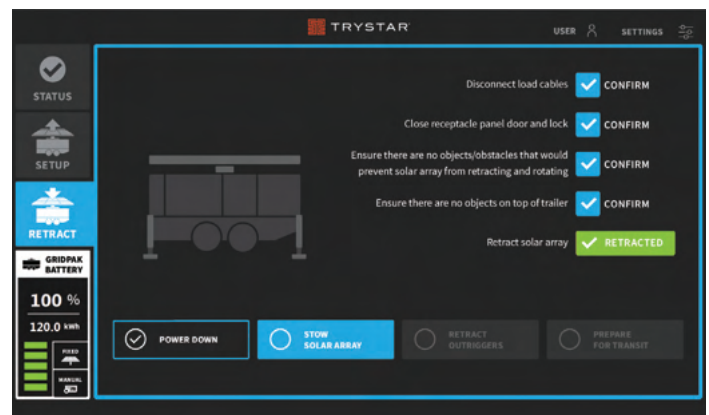

## 4.0 OPERATION

### 4.5.3 Retract Solar Array

The Operating System will automatically illuminate the **RETRACT OUTRIGGERS** button on the bottom of the display as well as show the associated set of directives/confirmations.

The next step is to retract the outriggers.

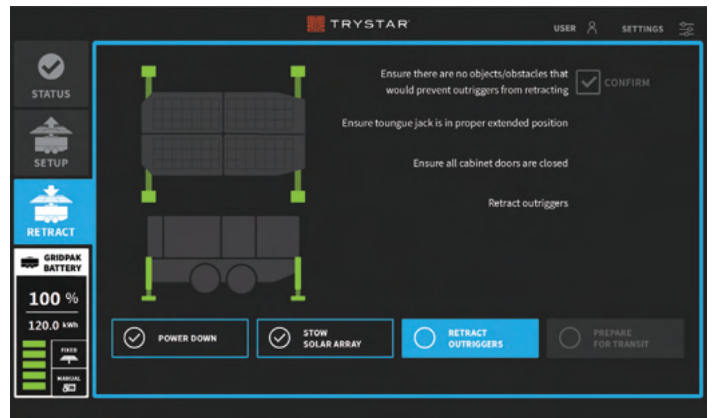

## 4.0 OPERATION

### 4.5.4 Retract Outriggers

**⚠ CAUTION**

Raising the outriggers to prepare the GridPak for transit can cause the trailer to roll or shift, resulting in minor or moderate injuries if not secured. If not done already, make sure the trailer is secured by placing the wheel chocks firmly in front and back of all trailer wheels. Place orange safety cones around the GridPak prior to retracting outriggers.

Before retracting the outriggers, moving the towing vehicle into position may be advantageous for attaching the GridPak trailer. The trailer may shift unexpectedly when the outriggers are lifted, given site conditions may have changed since deployment. Allow several feet between the GridPak trailer tongue and towing vehicle hitch to account for any unexpected trailer travel once outriggers are retracted.

- Position safety cones in a 15-foot perimeter around the GridPak

The GridPak graphic image will initially show the outriggers extended and down. Before initiating the outrigger retraction sequence, GridPak will ask you to ensure no obstacles/obstructions will prevent or impede retraction.

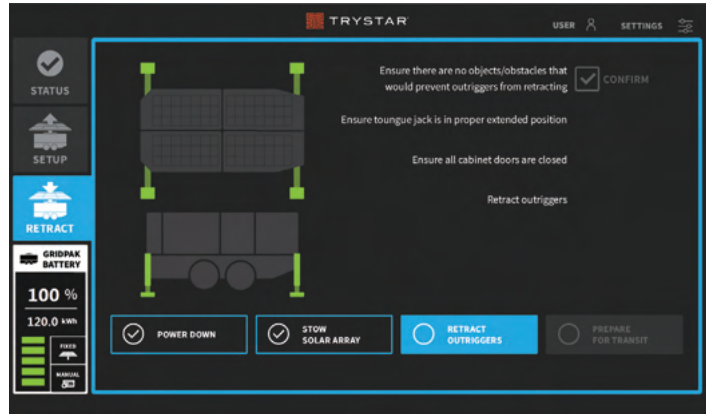

**⚠ CAUTION**

Ensure there are no tools or other items on top of the outrigger tubes to avoid damage to GridPak.

- Ensure there are no obstacles/objects that could prevent the outriggers from retracting
- Press CONFIRM

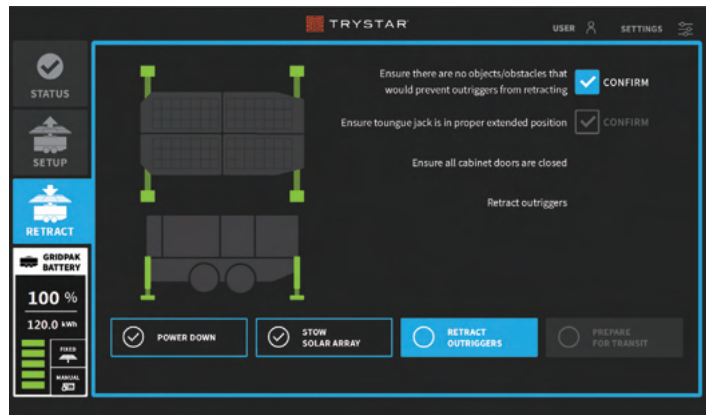

## 4.0 OPERATION

### 4.5.4 Retract Outriggers

**⚠ CAUTION**

Keep hands and feet away from the foot of the trailer tongue jack as it travels up/down to avoid injury.

- Switch the on/off toggle switch on the hydraulic jack mast to "on" to provide additional illumination should it be needed to facilitate attaching GridPak to the tow vehicle



**⚠ CAUTION**

Do not extend the tongue jack too low in preparation for connecting the trailer to the tow vehicle. The weight of the GridPak while being lowered to the ground by the outriggers could put undue stress on the unit resulting in damage.

- Ensure tongue jack is lowered to the optimum extended position if necessary
- Press CONFIRM

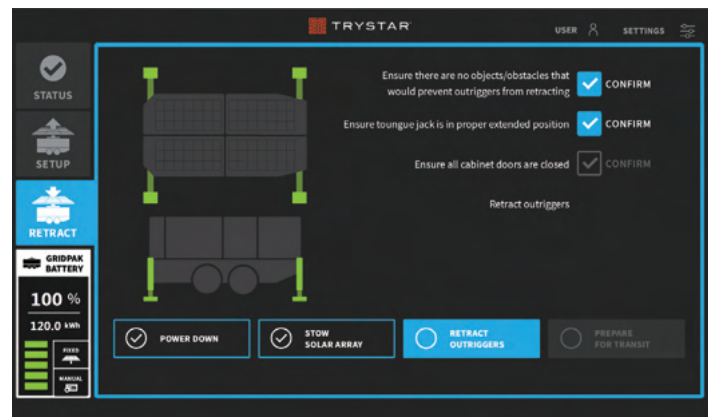

- Ensure all cabinet doors are closed to prevent potential damage
- Press CONFIRM

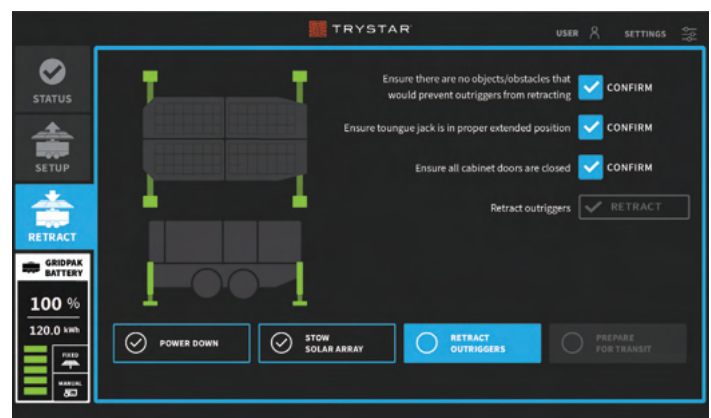

## 4.0 OPERATION

### 4.5.4 Retract Outriggers

The next command is to raise and stow the outrigger legs by pressing the RETRACT directive/confirmation check box on the right side of the display. Once the command is confirmed, a warning tone and light will activate to caution operators/personnel to stay away from the outriggers as they retract.

- Press the RETRACT check box

Once the RETRACT command is pressed the command check box will change to orange and read RETRACTING.

The retraction process will take a few minutes. All four legs will raise simultaneously to prevent GridPak from tipping. Once the legs are fully raised and the wheels are on the ground, it will then retract the outrigger arms one side at a time. When the process is completed, the RETRACT check box will change to RETRACTED. The warning tone and light will cease operation and the outriggers on the graphic image will dim.

GridPak will automatically bring up the next set of directives/confirmations to guide the process of preparing it for transit.

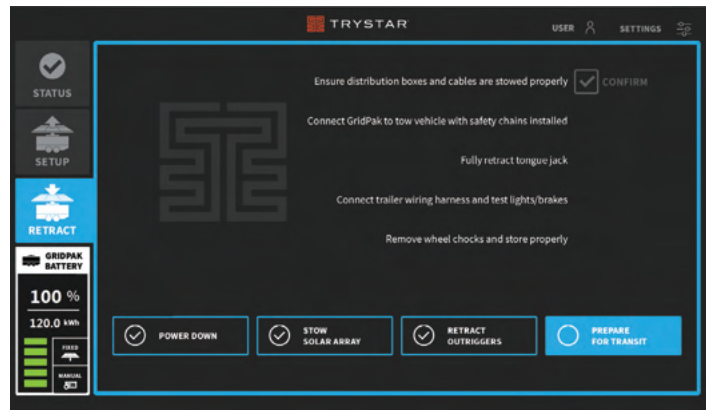
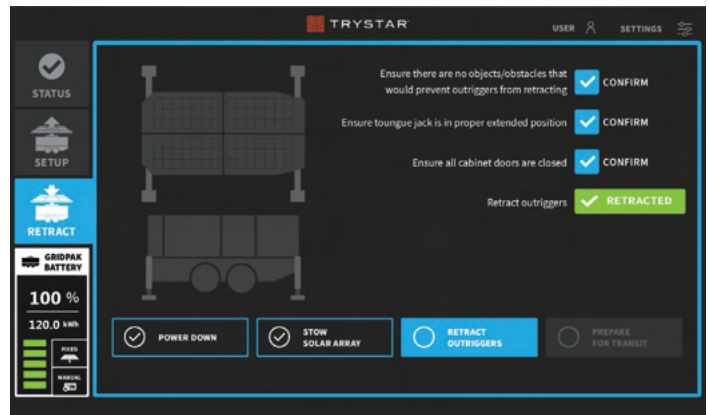
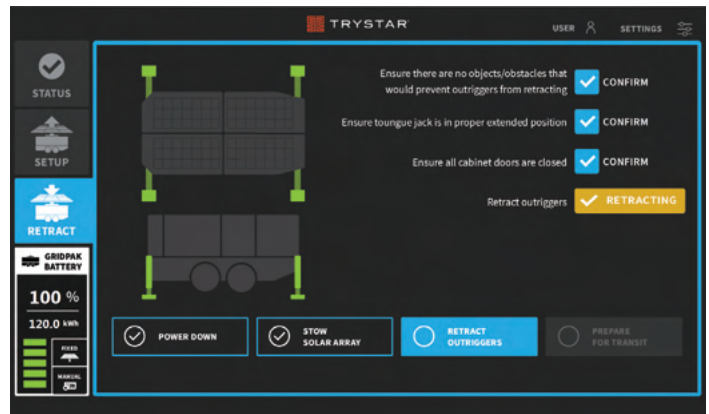
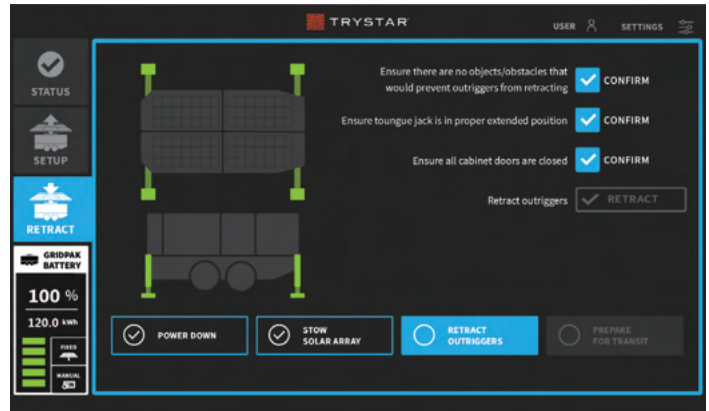

## 4.0 OPERATION

### 4.5.5 Prepare GridPak for Transit

When the outrigger retraction steps are concluded, a new screen will appear on the display to help you prepare the GridPak for transit. Keep the wheels firmly chocked and the safety cones in place. This is an opportunity to collect any tools, cables and other accessories that have not been stowed and place them in the GridPak storage areas or the tow vehicle.

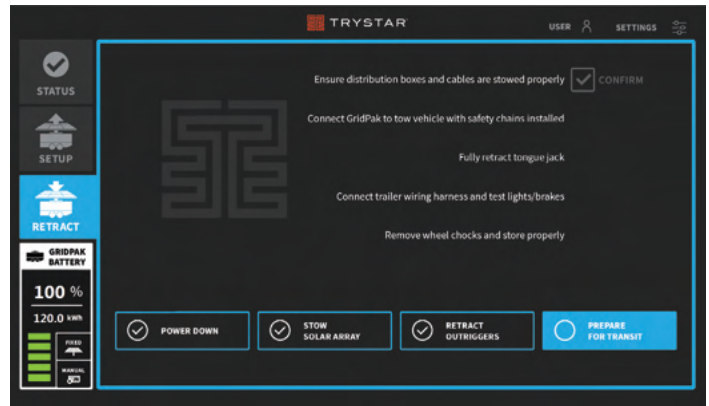

#### ⚠ WARNING

Cables between GridPak and energized loads pose tripping hazards that could cause minor or moderate injuries. Approach connecting points and cables with caution. Wear appropriate personal protective equipment (PPE) when working with cables connected loads and load devices.

### 4.5.6 Stow All Load Devices

- Ensure all devices, cables, accessories, tools and other items are stowed
- Press CONFIRM

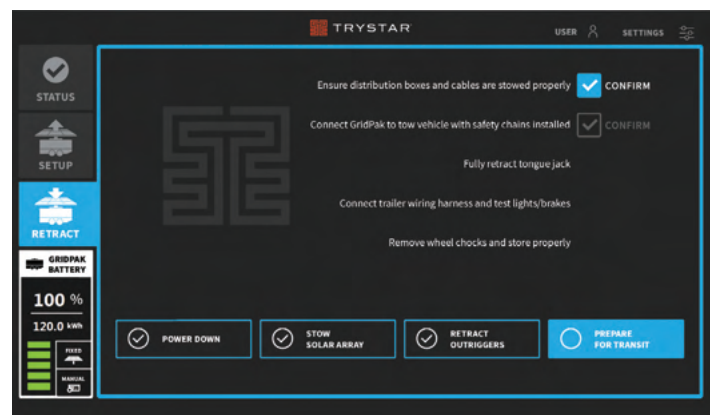

#### ⚠ CAUTION

Make sure the trailer remains secured with the wheel chocks firmly in place in front and back of each trailer wheel so that any unexpected movement (e.g., rolling or trailer tongue swinging) does not result in an injury. Keep the orange safety cones in place around the GridPak.

#### ⚠ CAUTION

Keep hands and feet away from the foot of the trailer tongue jack as it travels up/down to avoid injury.

### 4.5.7 Position Tow Vehicle and Trailer Tongue Jack for Hitch Connection

- With the wheel chocks still firmly in place, move the towing vehicle into position (or move it closer to the trailer tongue)

## 4.0 OPERATION

### 4.5.7 Position Tow Vehicle and Trailer Tongue Jack for Hitch Connection

**⚠ CAUTION**

Keep hands and feet away from the tow vehicle receiver and ball to avoid pinching or other injury. Keep hands and feet away from the trailer tongue jack as it travels up/down to avoid injury.

- Back the tow vehicle to the GridPak trailer hitch

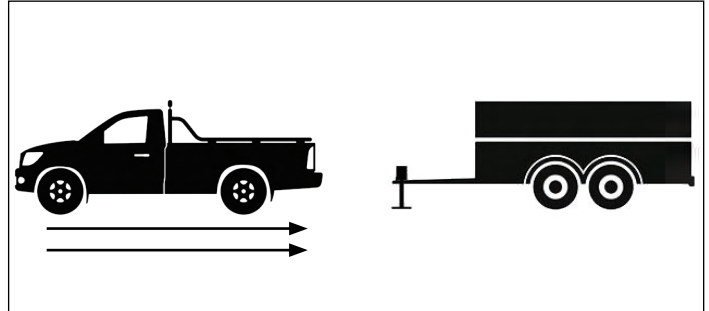

- Adjust the rocker switch up or down to match the tongue height of the tow vehicle hitch
- Move the tow vehicle to align and connect the hitch coupling



### 4.5.8 Reconnect Trailer to Tow Vehicle

- Connect the GridPak trailer to the tow vehicle and cross/connect the safety chains
- Press the CONFIRM check box on the GridPak display panel after you have completed the step above

The CONFIRM check box will illuminate.

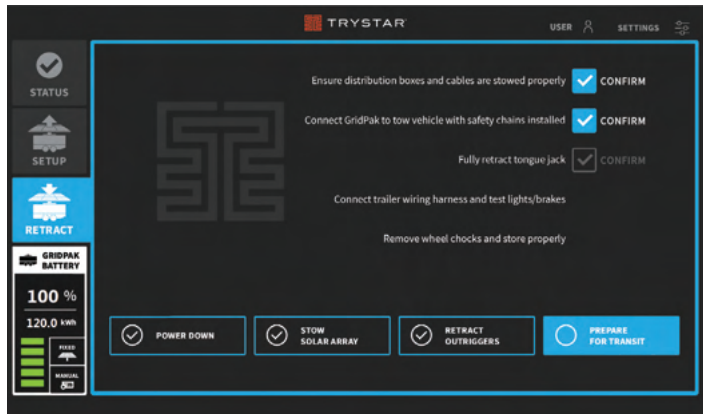

## 4.0 OPERATION

### 4.5.8 Reconnect Trailer to Tow Vehicle

- Continue to toggle the tongue control button “up” to retract the tongue jack fully into the jack mast

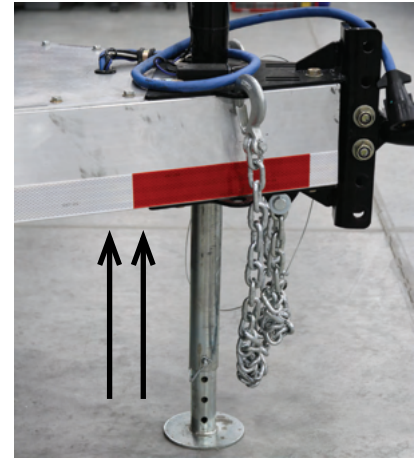

- Press CONFIRM to validate jack mast retraction  
The CONFIRM check box will illuminate and be checked.

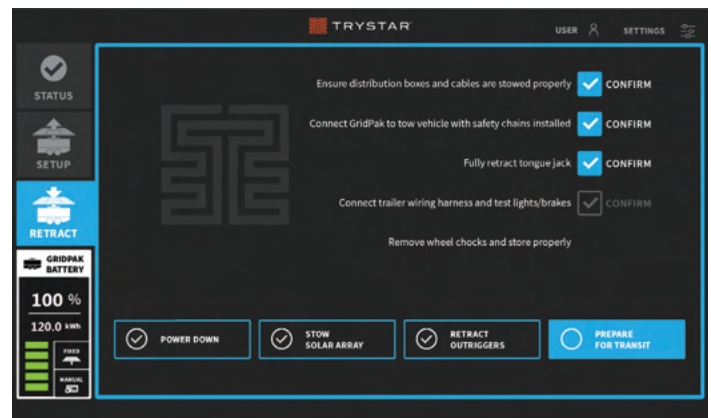

- Connect the brake/turn/running lights connection plug between the trailer and the vehicle.

- Attach the trailer safety breakaway cable carabiner to the tow vehicle

- Test brake/turn/running lights on the trailer and make other necessary transit preparations

- Press CONFIRM to validate proper operation of brake/turn/running lights

- The CONFIRM check box for the connection process will illuminate

- Remove wheel chocks and return to Accessory Cabinet

- Press CONFIRM to validate stowage of wheel chocks

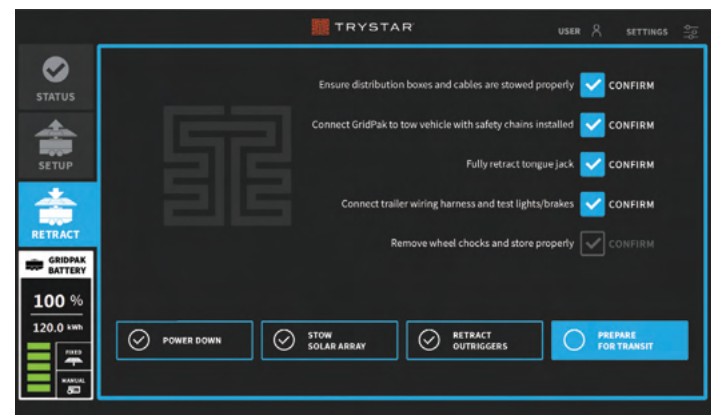

## 4.0 OPERATION

### 4.5.8 Reconnect Trailer to Tow Vehicle

The CONFIRM check box for wheel chock stowage will illuminate as will the Trystar logo signaling completion of the transit process.

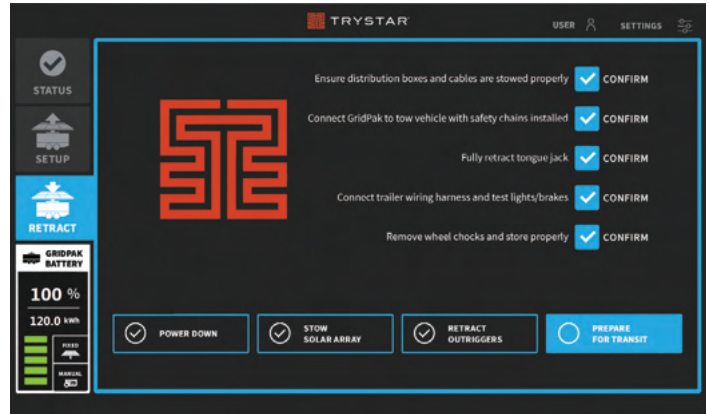

### 4.5.9 Sleep GridPak Operating System

On completion of the final transit preparation step, the GridPak display will automatically return to the STATUS command at left. After approximately 10 minutes, the operating system will go to sleep and the screen will go black until awakened. It is important to not allow the LiFePO<sub>4</sub> batteries to fully discharge in order to make the next deployment easier and faster.

- Close and lock the display screen cabinet door
- Place all cabinet keys in a safe place within the cab or a pocket for transit

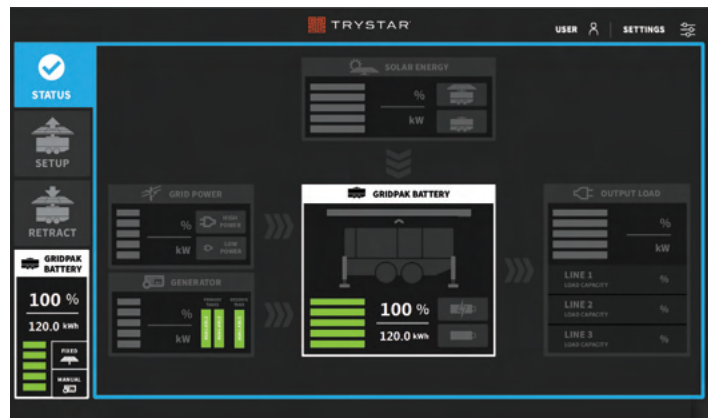

## 4.0 OPERATION

---

### 4.5.10 Final Transit Inspection

It is assumed that the trailer wheel condition, lubrication, and tire inflation were checked before deployment at the site. As time and conditions change, it may be necessary to ensure the tires are correctly inflated before transit from the project site.

It is advisable to visually inspect GridPak to ensure all accessories are returned and secure in their designated locations. Further, all cabinets should be closed and secured, and keys should be collected and retained in the truck cab or on the operator's person. Following are some steps to observe before transit:

- Ensure there are no loose items on GridPak that can come unstowed (fly or roll off) and pose road hazards
- Ensure all cabinet doors are fully closed and their latches secure and locked

## 5.0 CLEANING/MAINTENANCE

---

### 5.1 Cleaning

To keep the GridPak operating smoothly and efficiently it is important to maintain the solar arrays and other moving parts. In addition to conventional care used with any sophisticated piece of equipment, the following is recommended.

### 5.2 Cleaning/Protecting Solar Array

#### NOTICE

Using GridPak in "salty" conditions (near the ocean or near salted roads in winter conditions) necessitates cleaning the solar panels and exterior surfaces of the GridPak as soon as possible to maintain proper performance and to enhance durability. Exposure to salt spray or similar conditions degrades electronics and electrical circuitry and connections.

#### NOTICE

Use only fresh water and/or fresh water on a clean non-abrasive cloth to clean solar panels to avoid damage. Do not clean solar panels using brushes or other tools that directly touch the panels and **do not use a pressure washer**.

#### NOTICE

To avoid damaging the solar panels, avoid exposing the panels to extreme inclement weather, including high winds in excess of 50 MPH and hail. Cover the panels to protect them from hail.

Properly maintaining the GridPak's solar array will allow it to operate correctly and enhance longevity. If the GridPak is used in salty conditions, its solar panels and exterior surfaces should be cleaned as soon as possible. The following should be performed on a regular basis and each time before the GridPak is deployed.

- Clean dust or dirt from the solar panels with fresh water (**No Pressure Washer**) or a clean damp cloth
- To clean stubborn stains, use Isopropyl alcohol on a clean damp cloth

## 5.0 CLEANING/MAINTENANCE

### 5.3 Deployment/Retraction Mechanism Lubrication

Before and after each deployment, and prior to mechanism maintenance, check for any debris within any part of the deployment/retraction mechanism. GridPak has been designed with certain safeguards to prevent damage from occurring but they are not failsafe. The owner/operator is ultimately responsible for ensuring debris and obstacles do not damage the array and mechanism.

Maintaining the deployment/retraction mechanism under the solar array will maximize GridPak's performance and durability. There are several grease zerks on the array and the azimuth. A standard grease gun with a high-quality, heavy-duty grease suitable for outdoor conditions is recommended.

- Grease each of the eight zerks on the GridPak solar array as shown

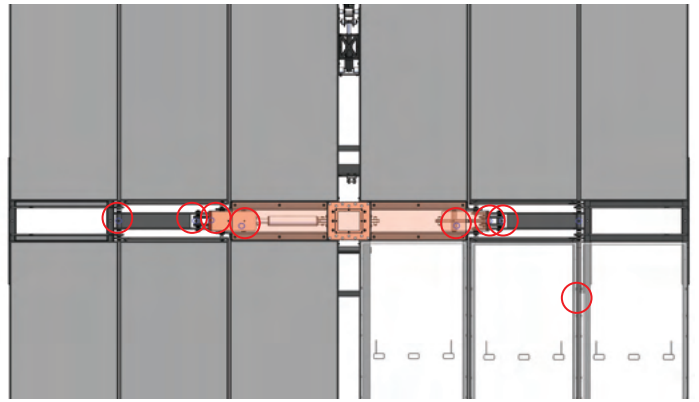

Eight grease zerks on the GridPak solar array

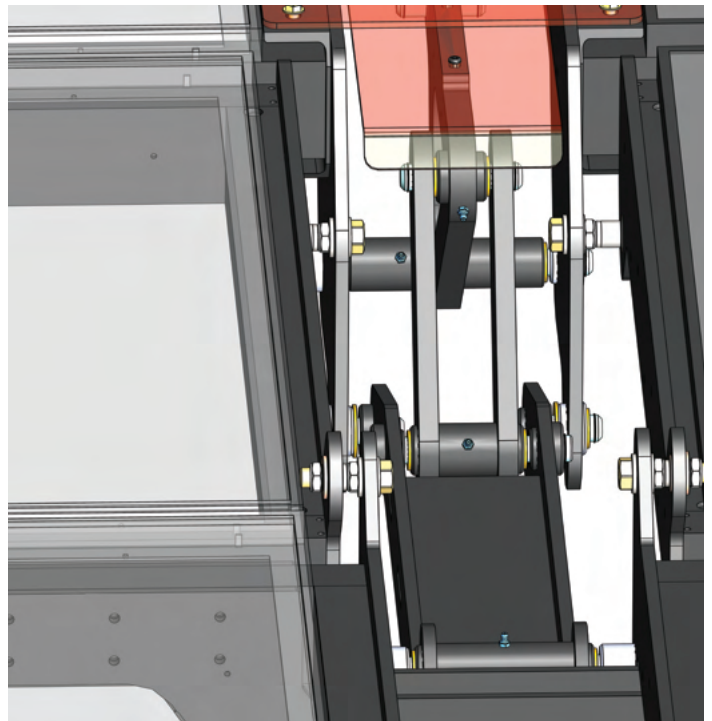

Closeup of zerks on one side of the solar array

## 5.0 CLEANING/Maintenance

---

### 5.3 Deployment/Retraction Mechanism Lubrication

The deployment/retraction azimuth has three grease zerks.

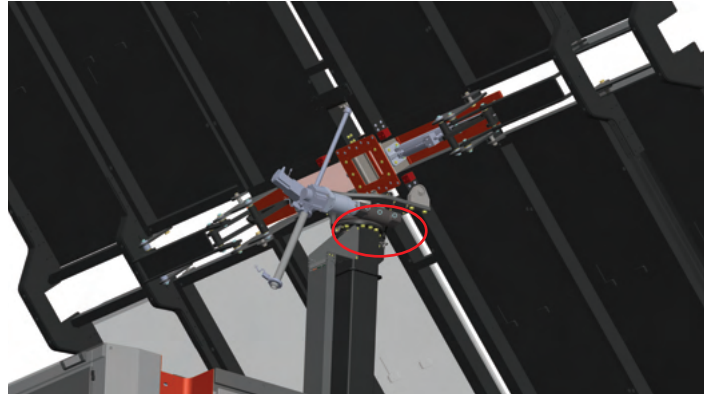

- Grease each of the three zerks on the GridPak azimuth as shown



## 6.0 CHANGING LP TANKS

### 6.1 Key Component Locations and Hardware

The figures below illustrate the location of the LP tank cabinet on the GridPak and the inside of LP tank enclosure.



LP Tank Storage Cabinet Door



LP Tank Storage Cabinet Interior

## 6.0 CHANGING LP TANKS

### 6.1 Key Component Locations and Hardware



POL LP Tank Fitting



LP Tank Safety Ratchet Strap



Non-Serviceable Pressure Regulator Valve

## 6.0 CHANGING LP TANKS

### 6.2 Accessing LP Cabinet Panel

#### NOTICE

The cabinet door has a locking arm at upper left. Push up on rod arm to disengage lock to avoid damage to hardware and mechanism before attempting to close.

- Pull out ring handle cabinet latch and rotate 90 degrees
- Swing cabinet door to the left and open until it reaches the locked position – approximately 90 degrees



Once the cabinet door is open and locked into the open position, it is possible to examine and manipulate the LP tanks.

A black safety ratchet strap holds the tanks in place.

Two tanks are in service at any one time. Both high-pressure hoses feed into the regulator valve.

***Pressure is set/fixd by the pressure regulator and matches the necessary specifications set by the generator manufacturer to allow proper generator operation. Do not tamper with or attempt to adjust the regulator.***



#### ⚠ CAUTION

The LP tanks weigh 55-60 pounds each when filled and are approximately 20-30 pounds when empty. When exchanging tanks, it will be necessary to lift them down from the LP cabinet floor. Be prepared to lift/manage tanks as they can cause injury to feet, legs and hands if not handled with caution.

## 6.0 CHANGING LP TANKS

### 6.3 Disconnecting LP Tank Hardware

#### ⚠ WARNING

Make sure the generator is switched off before working with the tank system. **See Manual Programming, Section 7.9.2.** Do not smoke or use any electrical devices when servicing the LP fuel tanks. An open or smoldering flame or spark can ignite errant fuel due to a leak or other failure and cause severe injury or death.

Before loosening the black safety ratchet strap to remove the tanks, it will be necessary to close the tank valves and disconnect coupling(s) with a 7/8-inch open-end wrench.

LP Tank On/Off Valve



- Turn LP gas **off** on both (or all) tanks in service by turning the LP tank on/off valves clockwise



- Disconnect the fitting from each LP tank, one at a time, by turning the fitting **clockwise**. **The fittings are reverse-threaded**

**NOTE:** It is normal to hear a small exhalation of gas during the uncoupling process. This is normal.



## 6.0 CHANGING LP TANKS

### 6.4 Removing Empty LP Tanks

#### ⚠ CAUTION

The LP tanks weigh 55-60 pounds each when filled and are approximately 20-30 pounds when empty. When exchanging tanks, it will be necessary to lift them down from the LP cabinet floor. Be prepared to lift/manage tanks as they can cause injury to fingers, feet, legs and hands if not handled with caution.

Once the coupling hardware and hoses have been removed from the LP tanks, it is possible to loosen the black safety ratchet strap to remove the tanks from the enclosure for exchange with full LP tanks. Simply lay the disconnected hoses aside. The regulator will hold them while tanks are being serviced.



- Loosen the safety strap by releasing the catch on the ratchet. Pull extra strap out by holding the release and rolling it out of the ratchet mechanism



- With the LP tank couplings disconnected and the black safety strap untethered, carefully lift the tanks down from the enclosure to ground level

Use a hand truck or dolly to move the tanks out of the way so its possible to hoist full tanks from ground level into the LP tank cabinet.



## 6.0 CHANGING LP TANKS

### 6.5 Reconnecting Hardware to Full LP Tanks

- With the black safety strap loosely in place to accommodate the three tanks, carefully lift the fresh LP tanks into the GridPak LP tank cabinet.



Before reconnecting the couplings to the full LP tanks, it is first necessary to orient the on/off valve threads to facilitate connections.

- Orient the Tank 1 valve threads so they face left, parallel with the cabinet back. Do the same with Tank 2. Orient Tank 3 valve threads in the opposite direction so they face to the right but remain parallel to the cabinet back



Tank 3  
Extreme  
Left

Tank 2  
Middle

Tank 1  
Extreme  
Right

- Reposition the loops of the black safety strap around each LP tank appropriately and gradually start taking up the slack. Once positioned, snug the tanks tightly to the cabinet wall by taking up all slack using the ratchet handle



- Attach the POL fittings to the two (or more) LP tanks by screwing them into the female fittings, **counter-clock-wise**. Secure tightly with a 7/8-inch open-end wrench to avoid a poor connection and/or leaks



## 6.0 CHANGING LP TANKS

### NOTICE

The cabinet door has a locking arm at upper left. Push up on rod arm to disengage lock to avoid damage to hardware and mechanism before attempting to close.

### 6.6 Turn on LP Fuel Tanks

- Turn on the flow of gas from each LP fuel tank by rotating the on/off handle counter-clockwise

LP Tank On/Off Valve



### 6.7 Close and Lock LP Fuel Tank Enclosure

- Release the cabinet door locking arm by pushing it slightly upward, and while holding it, swing the door slightly to the right
- Once in the unlocked position, swing the cabinet door to the almost closed position, ensuring the locking cabinet handle is in the 90 degree position so it can close and lock properly
- Push the cabinet door in firmly and twist the locking cabinet handle back to the vertical position and lock with the key



## 7.0 MANUAL PROGRAMMING

### 7.1 Entering Manual Programming

While the GridPak is easy to fully deploy in a matter of minutes, there may be occasions when the operator wants to access or program certain functions. The manual programming design feature facilitates GridPak inspection, maintenance and service. Further, it allows the operator to control for operating conditions like limiting noise (generator operation) during specific hours, enhancing charging and efficiency, or protecting GridPak from excessive weather conditions. An operator can access these manual programming features through the "Settings" menu button on the home screen as shown below.

The GridPak should be appropriately sited and secured. Safety devices should be deployed and other safety measures implemented prior to manual programming. See **Section 4.3 Deploying GridPak** of this operating manual to enhance operator or technician safety. Power up the GridPak Operating System to engage in manual programming. Commands are entered on GridPak's main control panel, featuring the LCD touchscreen display and interface.

Manual programming was developed primarily to facilitate inspection, maintenance and service as previously noted. It should be understood that in the majority of cases, the operator or technician should ensure that GridPak is entirely powered down before initiating any inspections, maintenance, repairs or service.

- From the STATUS home screen, press SETTINGS to access manual programming mode

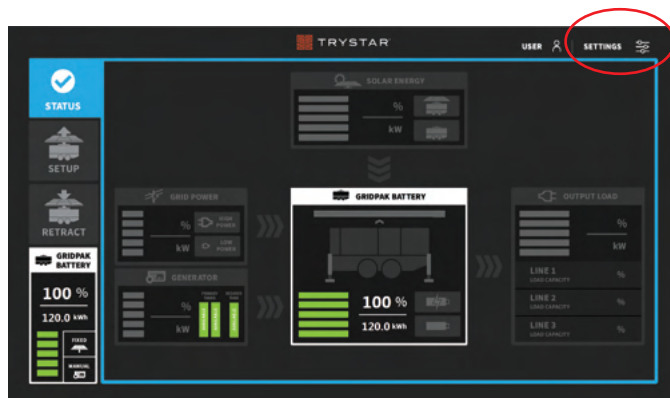

When the SETTINGS button is pressed, the STATUS function tab will gray out and nine manual programming tabs will appear at left.

Select the programming tab of choice by pressing it. It will then illuminate.

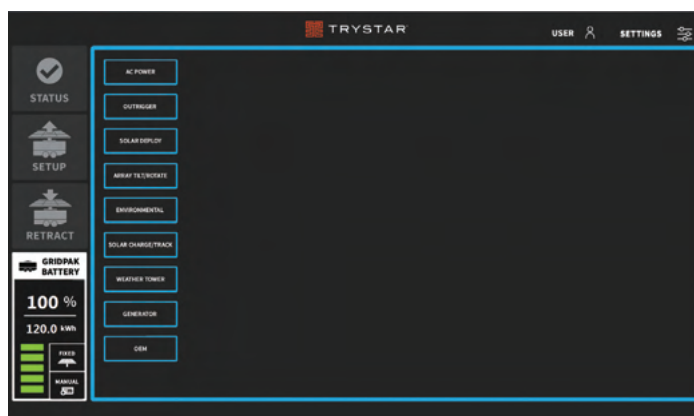

## 7.0 MANUAL PROGRAMMING

### 7.2 AC Power Programming

- From the STATUS function tab, press the SETTINGS button to enter manual programming mode

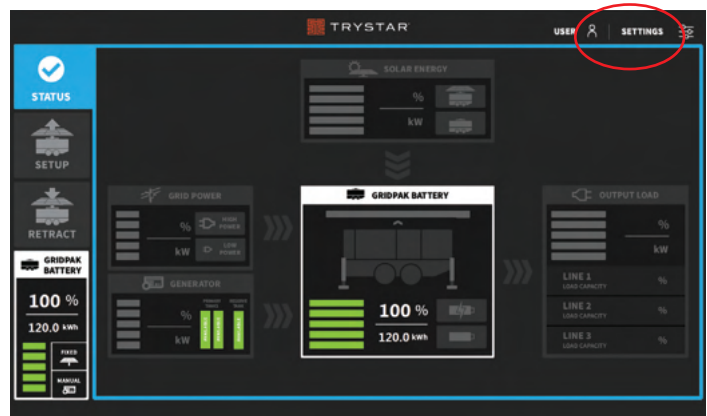

The ideal and preferred state for charging the GridPak batteries is via the solar panels and solar charging is always available, weather permitting. However, there may be times (e.g., when sitting in the yard or in inclement weather) that charging from another source is necessary or preferable. The options are to use a utility source or the onboard generator. Either can be accessed through the AC POWER button.



If choosing a utility source to charge the GridPak, the operator should become familiar with the electrical input subpanel featuring built-in breakers (See Section 4.1). It is located on the side of the GridPak toward the trailer tongue. It contains inputs for three-phase (High) and single-phase (Low) power. It is assumed that before entering into manual programming mode, the operator will have elected one of these utility charging options.



- Press the AC POWER button to enter programming mode for charging options and inverter monitoring

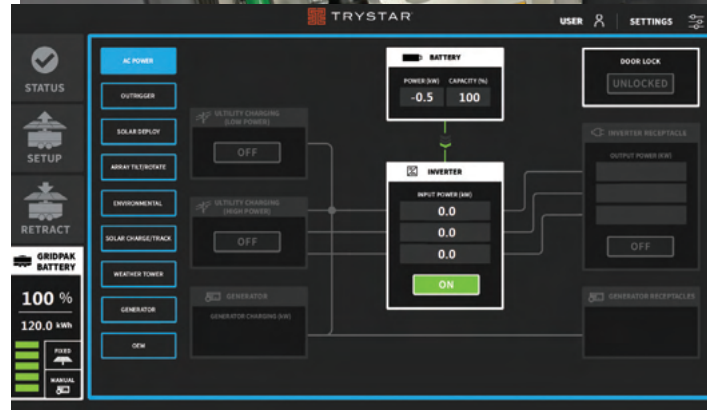

## 7.0 MANUAL PROGRAMMING

### 7.2 AC Power Programming

Once pressed, the AC POWER programming selection will reveal three charging methods that are mutually exclusive. Only one can be used at a time. The three selections are grayed out until one is chosen by pressing the "ON/OFF" button. The default position is "OFF."

Choosing the Utility High Power option is the fastest means of charging the batteries. It leverages a 208 VAC three-phase power source from which is drawn ~80 Amps (~25-30 kW).

Many business do not have a 208 VAC connection. The Utility Low Power option is designed to accommodate the most common connections which are 120 VAC. The 120 VAC connection allows an operator to use a conventional power cord plugged into a 15-20 Amp outlet.

Choose the Utility Low Power option to leverage a 120 VAC single-phase connection drawing ~16 Amps (~1.9 kW).

Choose the Generator option to leverage a 120 VAC single-phase connection drawing ~50 Amps (~6 kW).

#### 7.2.1 AC Power Tab Screen Meters

There are three meters on the AC POWER button tab screen. These include "AC Power," "Battery" and "Output Load."

**NOTE:** A voltage phase imbalance can lead to poor performance, stress, vibration, overheating, reduced service life and damage to downstream electrical devices.

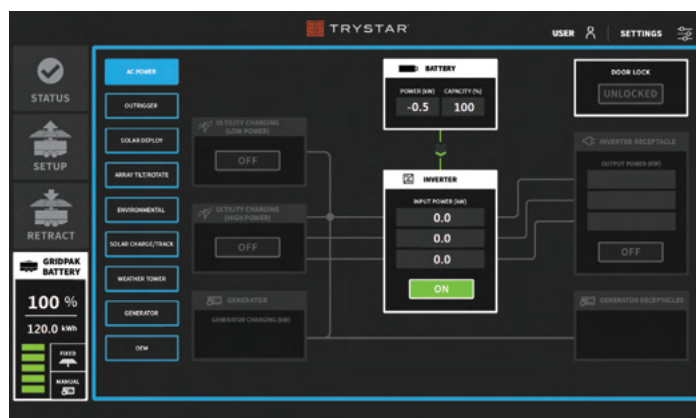
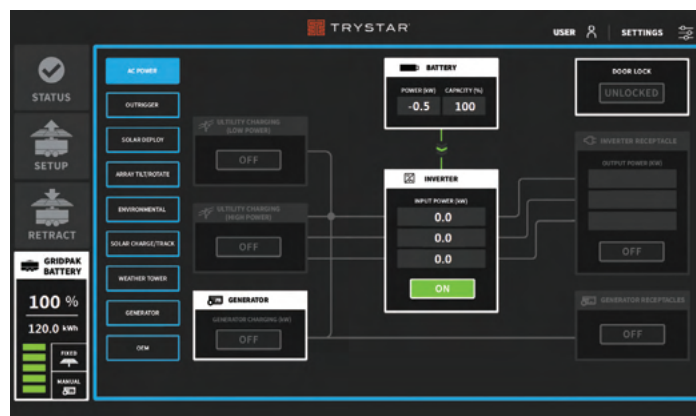
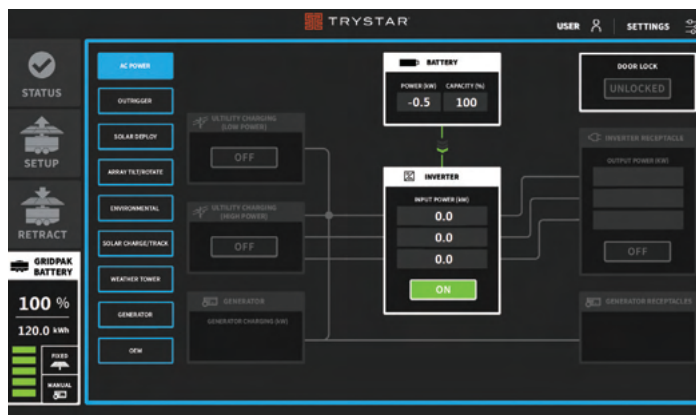

## 7.0 MANUAL PROGRAMMING

### 7.2.1 AC Power Tab Screen Meters

The Inverter (AC Power) meter allows the operator to see the balance and input (kW) for each of three phases when the meter ON button is pressed/activated and GridPak is set to charge its batteries using a Utility High Power connection. Similarly, the meter will show the single-phase input power (kW) when the batteries are being charged from a Utility Low Power connection or by the onboard generator – also single phase. Single-phase numbers are shown in the top bar of the meter only.

The Battery meter monitors all three charging modes. The first metric shows the charge level as measured in kW. The second metric shows the level to which the batteries are charged. One-hundred percent is fully-charged.

When the Inverter Receptacle meter is switched ON, it displays output power (kw) by individual phase. In a single-phase application, only the top bar shows the output power.

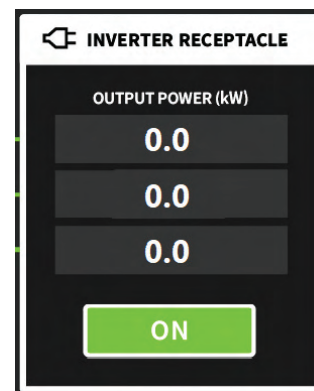
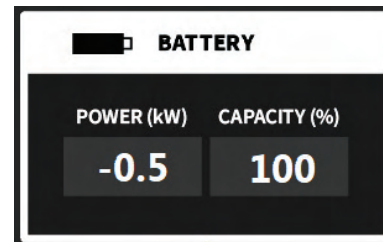
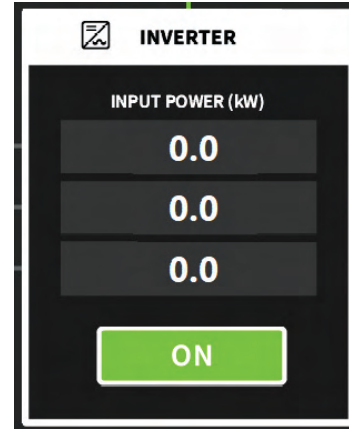

## 7.0 MANUAL PROGRAMMING

### 7.2.2 Utility Charging High Power

- Press the Utility High Power ON button to leverage a 208 VAC three-phase connection for fastest charging

The ON/OFF button will turn green and the Inverter meter (when switched on) will show the input power (kW) of each of the three phases. The charge and capacity of the battery will also display just above the Inverter meter in the Battery meter. The Generator and Low Power Utility Charging buttons will remain grayed out as only one of the three charging methods can be applied at one time.

If there is a current draw on GridPak in the Utility High Power mode, it will be shown on the Inverter meter by phase when the meter is set to the ON position. The default position is OFF. The button also controls whether any connected devices are permitted to operate by GridPak power.

The AC POWER display screen also contains a button to lock and unlock the Load Connector cabinet door adjacent to the control panel. This allows the operator to connect or disconnect loads. The default is UNLOCKED.

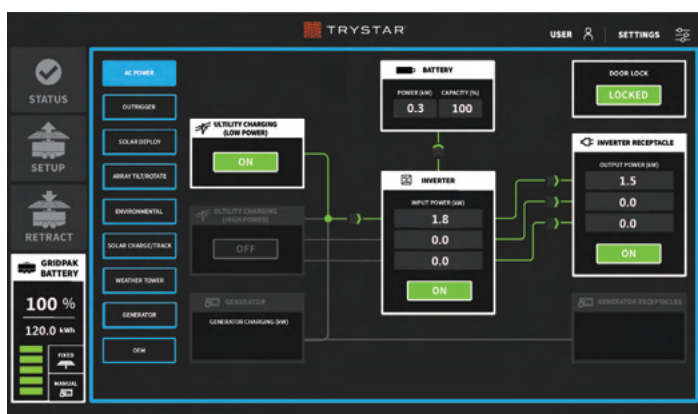
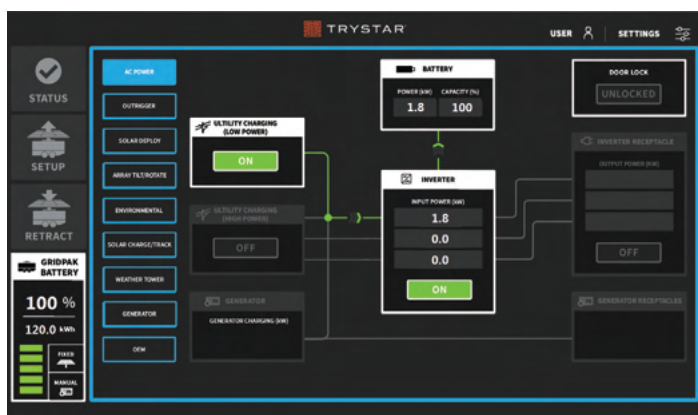
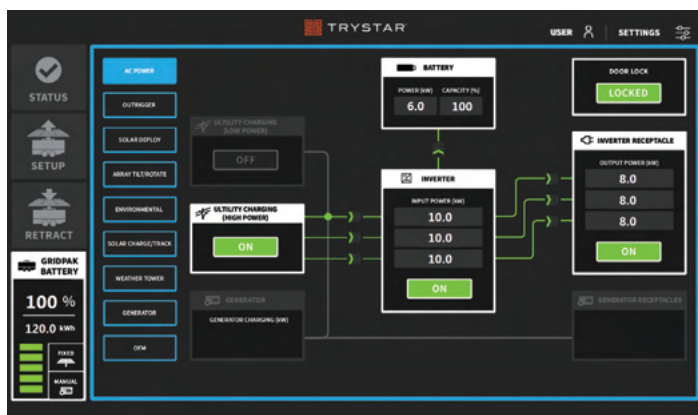
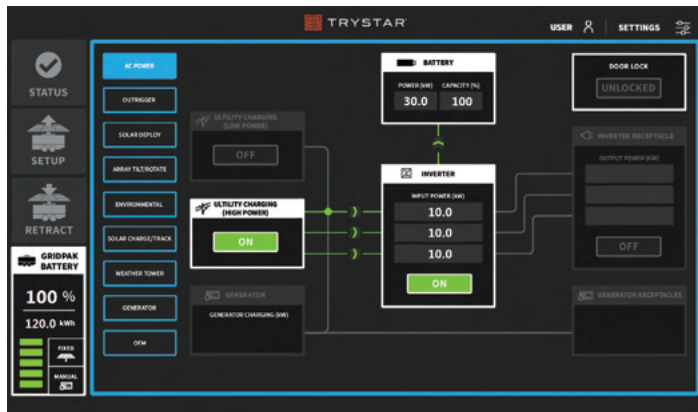

### 7.2.3 Utility Charging Low Power

- Press the Utility Low Power ON button to leverage a 120 VAC single-phase connection

The ON/OFF button will turn green and the Inverter meter will show the input power (kW) for a single phase. The charge and capacity of the battery will also display just above the AC Inverter meter in the Battery meter.

If there is a current draw on GridPak in the Utility Low Power mode, it will be shown in the top bar of the Inverter Receptacle meter when the meter is set to the ON position. The default position is OFF. The Inverter Receptacle ON/OFF button also controls whether any connected devices are permitted to operate on GridPak power. The Generator and High Power Utility Charging buttons will remain grayed out.

## 7.0 MANUAL PROGRAMMING

### 7.2.4 Generator Charging

- Press the Generator ON button to charge the batteries using the onboard generator

**NOTE:** When the generator charging option is selected, it will be necessary to actually *start* the generator from the GENERATOR manual programming tab, discussed later in this manual (See Section 7.9).

The ON/OFF button will turn green and the Inverter meter will show the input power (kW) for a single phase. The charge and capacity of the battery will also display just above the Inverter meter in the Battery meter. The High and Low Power Utility Charging buttons will remain grayed out as only one of the three charging methods can be applied at one time.

If there is a current draw on GridPak in the generator mode, it will be shown in the Inverter Receptacle Output power meter when the Inverter Receptacle is set to the ON position. The default position is OFF. The Inverter Receptacle button also controls whether any connected devices are permitted to operate on GridPak power.

The AC POWER display also contains a button to lock and unlock the Load Connector cabinet door adjacent to the control panel. This allows the operator to connect or disconnect loads.

#### 7.2.4.1 Generator Contactor Operation

The primary purpose of the onboard generator is to supplement solar charging when weather or other conditions limit effective charging by sunlight alone. The GridPak, however, has dedicated receptacles (located in the Load Receptacle Panel) that are powered directly from the generator, not the inverter.

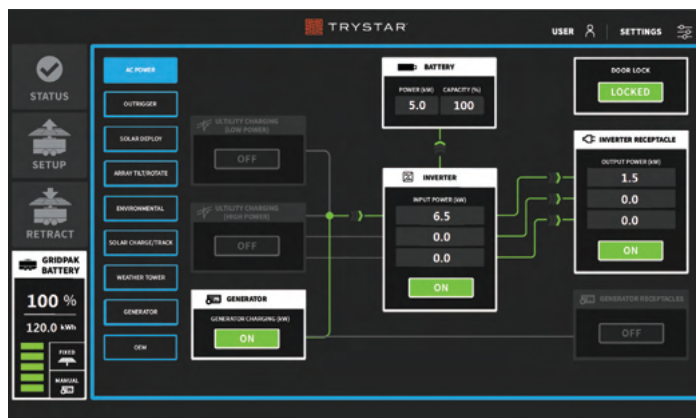
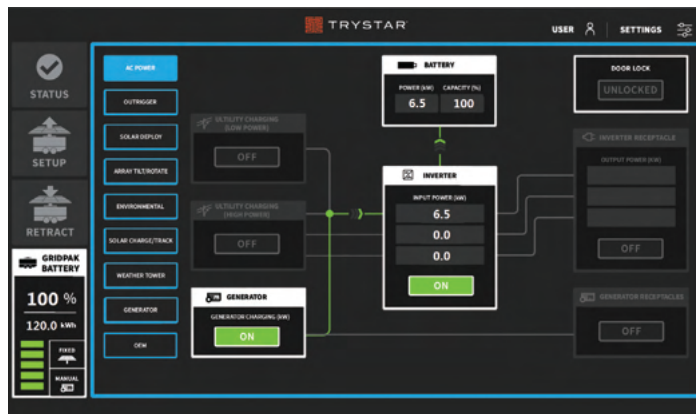

## 7.0 MANUAL PROGRAMMING

### 7.2.4.1 Generator Contactor Operation

This design feature allows the operator to get AC power directly from the generator in situations where the GridPak batteries may be drained, the inverter is not functioning due to a fault, or a related component fails.

Yet, when the generator is in charging mode, drawing power from the generator receptacles negatively affects its ability to charge the LiFePO<sub>4</sub> batteries. Therefore, a contactor is part of the circuit so the generator receptacles in the Load Receptacle Panel can be disabled.

In the adjacent illustration, the GridPak is being charged by three-phase utility power. Only one charging source (generator, high- or low-utility) can be used at a time to charge the GridPak as they are mutually exclusive. Since the generator is not in use for charging the batteries as shown, it can be used for other purposes by switching the Generator Receptacles button at right, ON. The generator itself can be turned on from the generator tab at left (**See Section 7.9**). When the receptacles are active, a green line will extend from the Generator meter (grayed out as it's not being used for GridPak charging) to the Generator Receptacles button – shown switched on.

In a conventional deployment, the solar generator will automatically activate as necessary to supplement solar charging. To ensure all generator power is being dedicated to charging the GridPak batteries, the Generator receptacles should be switched OFF.

### 7.2.5 Exiting Programming Mode

- Press the STATUS tab to exit manual programming mode

The display will return to the STATUS home screen.

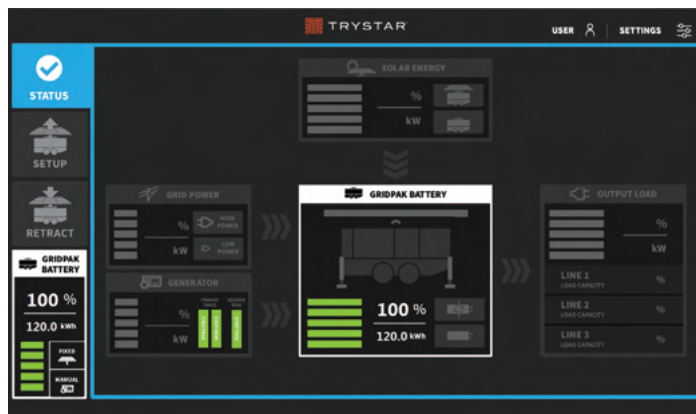
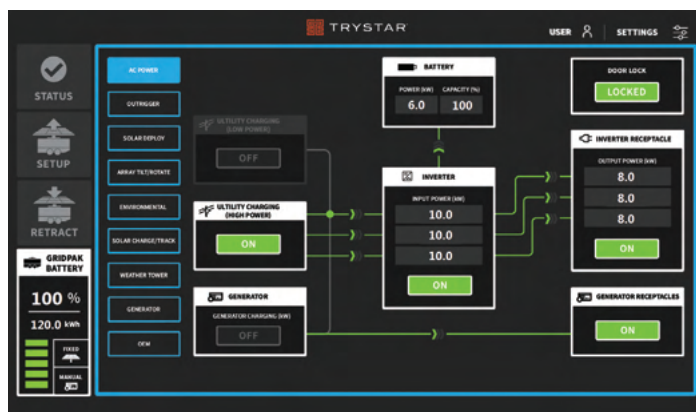

## 7.0 MANUAL PROGRAMMING

### 7.3 Outrigger Manual Programming

**NOTE:** Before proceeding, please review and implement all safety measures shown in **Section 4.3.5** pertaining to outrigger deployment.

The hydraulic outriggers are set to deploy and self-level automatically in a conventional application using the SETUP tab. Yet, it is possible to operate the legs manually for lubrication, system inspection and cleaning, and to review the hydraulic pressures to ensure there are no leaks or seal failures. The outriggers operate under tremendous force so it is important, even for maintenance or service, to observe all related safety precautions.

- Check to ensure there is at least 15 feet of space from sides/ends of GridPak
- Place safety cones around perimeter of GridPak matching the 15 feet of clearance from sides/ends
- Close any open cabinet doors on GridPak
- Ensure wheel chocks are placed firmly against the GridPak trailer tires, front and back

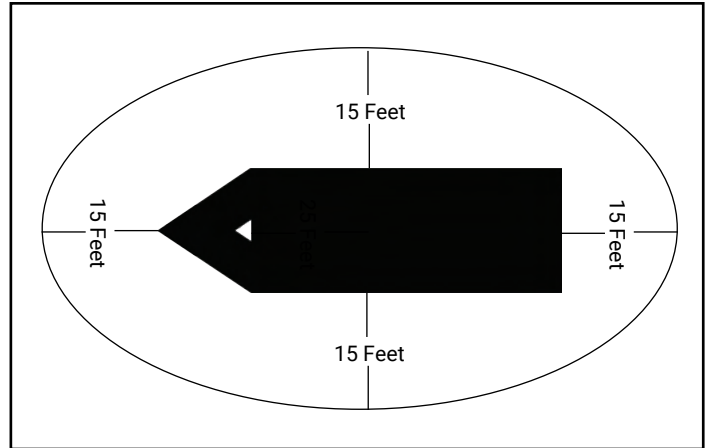

#### ⚠ WARNING

Operators should keep hands, feet, and other body parts away from the GridPak outriggers during deployment as they could cause severe personal injury or death. Operator(s) should ensure safety cones have been placed in a 15-foot safety perimeter around the GridPak and that no people or pets are within or allowed to enter within the 15-foot safety perimeter during deployment.

#### ⚠ CAUTION

GridPak's outriggers are deployed under significant force and can damage property. Make sure all GridPak equipment (e.g., cables) and other related equipment, including personal property, are well clear of the outriggers during deployment.

#### NOTICE

The GridPak outriggers are designed for placement on grass, dirt, gravel or other natural surface. The feet have cleats that will dig into a natural surface to help stabilize GridPak. If siting the GridPak on concrete, asphalt, or any other surface that is stable but otherwise could be damaged by the cleats, use the cleat foot pads which are in the Accessories Cabinet. Put one pad under each cleat before lowering the outriggers.

## 7.0 MANUAL PROGRAMMING

### 7.3 Outrigger Manual Programming

- From the STATUS function tab, press the SETTINGS button to enter manual programming mode
- Press the OUTRIGGER tab to enter manual programming mode

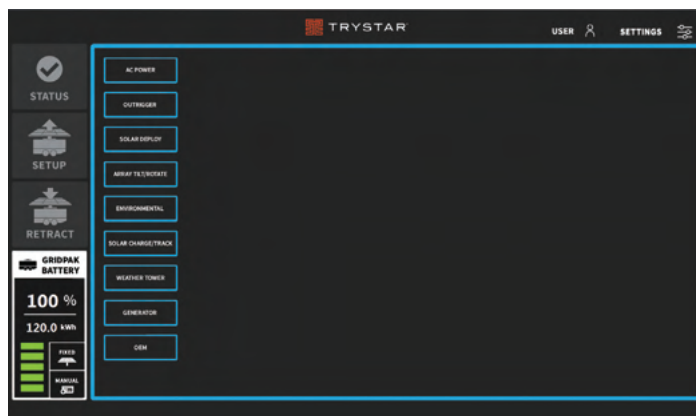
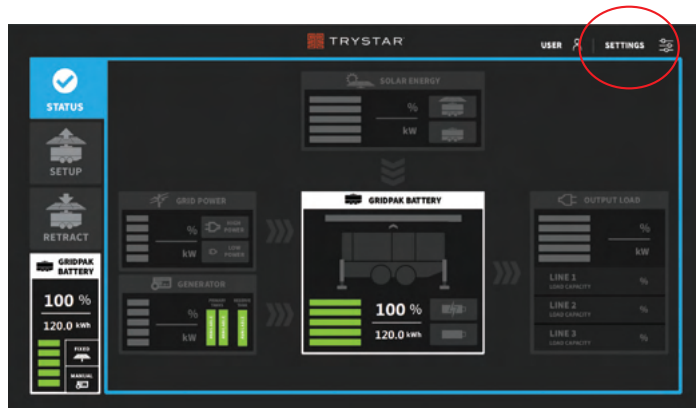

The split screens show the home positions for the outriggers in terms of extension (in and out) and elevation (up and down). There is no hydraulic pressure shown until the hydraulic pump is switched on and the GridPak is in the proper position to activate the outrigger arms and legs. For example, the leg controls will remain grayed out until the arms are first extended.

Though the display screen shows some buttons and schematics, the screen elements and overall background will remain dark gray until the hydraulic pump is switched on.

Further, the IN/OUT and UP/DOWN buttons are "momentary" meaning they will turn green when pushed but return to gray when pressure is released. This is normal.

Normal idle hydraulic pressures would never be greater than 100 lbs. in most situations.

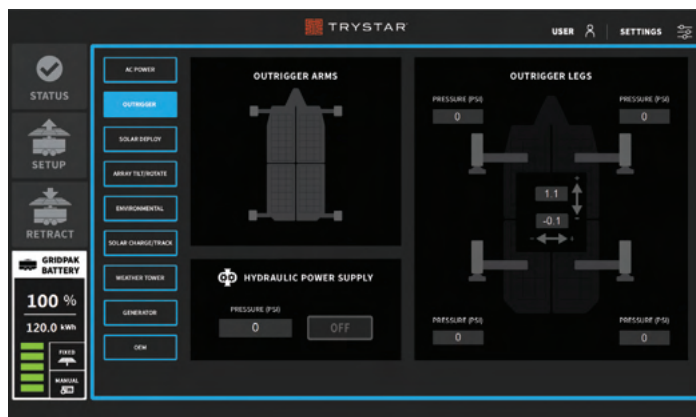

## 7.0 MANUAL PROGRAMMING

### 7.3.1 Manually Deploy Outriggers

- Press the ON/OFF button to energize the hydraulic pump
- The hydraulic power supply button will turn green and read ON. With the hydraulic pump engaged, the outrigger split screen will brighten signaling the operator that manual outrigger programming is available. From this screen, the operator can both extend and lower the outriggers. Only the IN/OUT buttons for the arms will show initially. The legs cannot be lowered until the arms are fully extended.

When you press IN or OUT to extend/retract the outrigger arms, a warning tone and light will activate to caution operators (and any bystanders) to stay away from the outriggers. The hydraulic pump will remain on until shut off. The warning tone and lights will continue while the IN or OUT buttons are pressed.

### 7.3.2 Manually Extend Outrigger Arms

- Press the OUT button to extend the outriggers to the desired position one side at a time

The outrigger arms in the display will turn orange until they are fully extended – then they will turn green. Movement can be stopped at any time.

**NOTE:** Switch the hydraulic pump OFF before engaging in any inspection or service procedure.

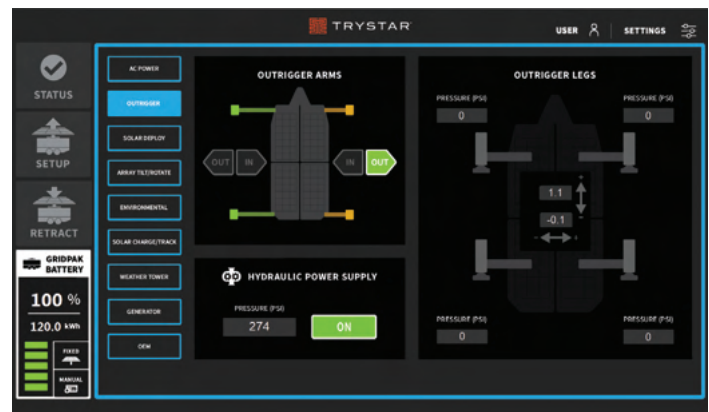
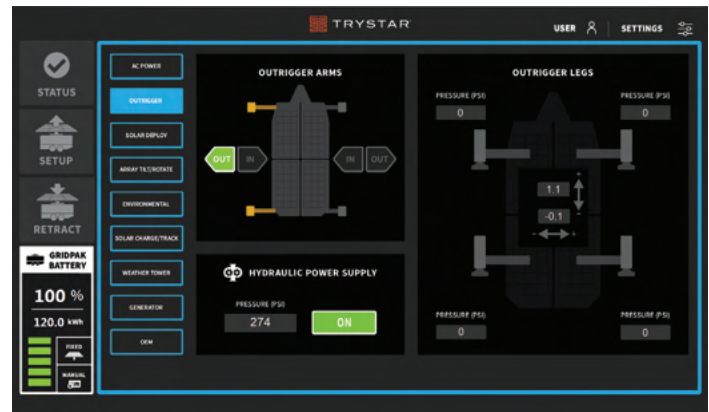
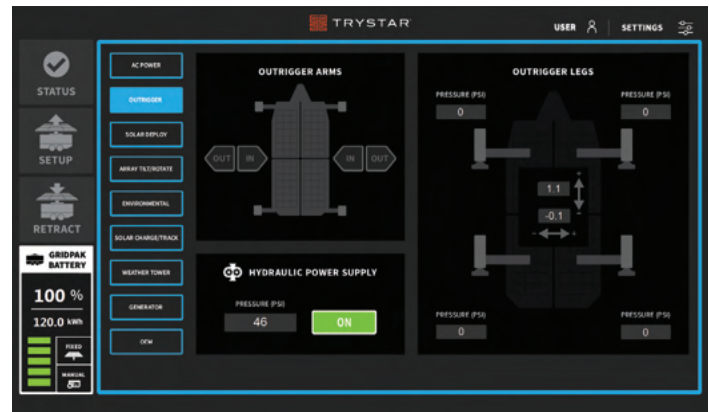

## 7.0 MANUAL PROGRAMMING

### 7.3.2 Manually Extend Outrigger Arms

When the outriggers are fully extended they turn green. The louder pump noise will cease when the OUT button is released. Simply release the OUT (or IN) button at any point to inspect or service the outrigger arms.

**NOTE:** Switch the hydraulic pump OFF before engaging in any service procedure.

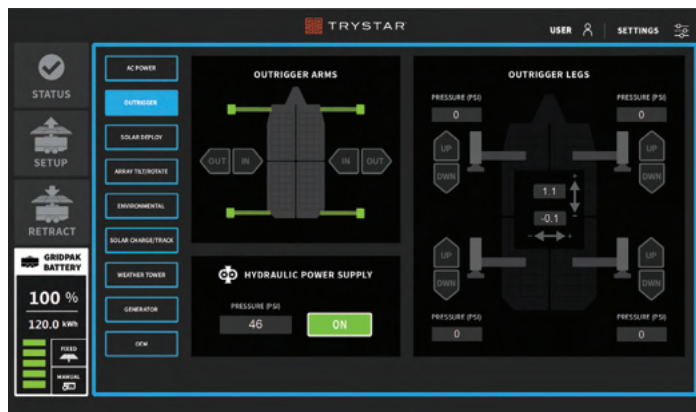

### 7.3.3 Manually Lower Outrigger Legs

- Press the DOWN button to lower the outrigger legs to the desired position, one leg at a time

A warning tone and light will activate to caution operators (and any bystanders) to stay away from the outrigger legs. As the outrigger legs are lowered (or raised), they will remain orange until they are fully extended (green) or fully raised in their stored positions (gray). The hydraulic pump will remain on until shut off. The warning tone and lights will continue while the UP or DOWN buttons are pressed. The hydraulic pressures will also be shown for each side.

The adjacent illustration shows the outrigger arms fully (left side of screen) extended but one leg partially lowered (right screen). Note both arms and legs are illustrated in orange in the right screen until the arm and leg are both fully extended.

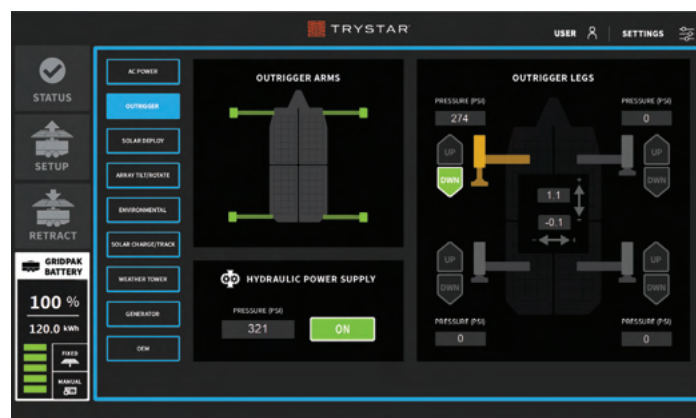
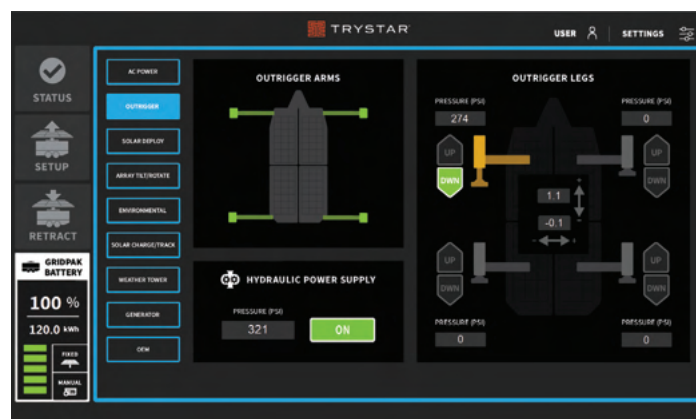

## 7.0 MANUAL PROGRAMMING

### 7.3.3 Manually Lower Outrigger Legs

The legs will appear in green when fully lowered. When fully raised, they return to gray.

**NOTE:** Switch the hydraulic pump OFF before engaging in any inspection or service procedure.

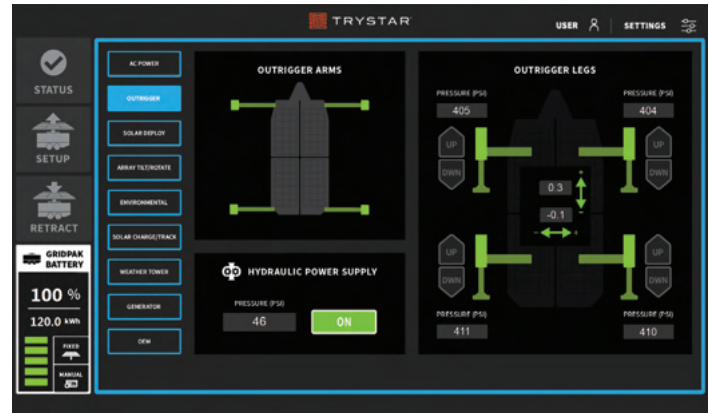

### 7.3.4 GridPak Level Meters

A leveling compass is contained within the outrigger leg schematic. The top box will show how high or low the trailer tongue is relative to the back end of the GridPak. The bottom meter shows the degree of level from side to side. There is no manual means of leveling the GridPak. This manual feature for extending and lowering the legs is intended to facilitate inspection, maintenance or service.

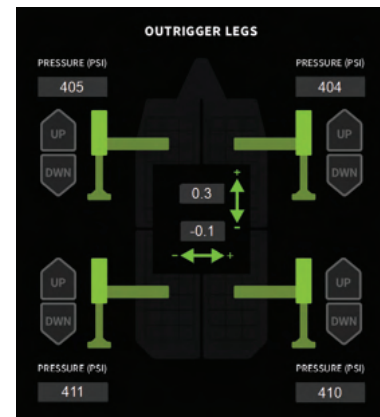

### 7.3.5 Exiting Programming Mode

- Press the STATUS tab to exit manual programming mode

The display will return to the STATUS home screen.

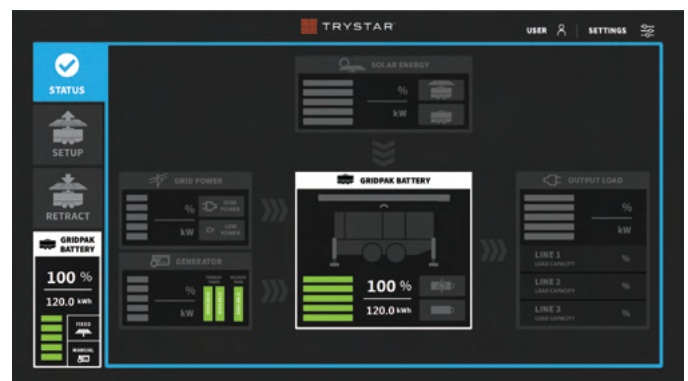

## 7.0 MANUAL PROGRAMMING

### 7.4 Solar Tower/Array Manual Programming

#### ⚠ CAUTION

To avoid damaging GridPak during service, it is important to ensure a minimum clearance of 35 feet of unobstructed space from the top of the unit and a minimum of 15 feet of free space (clearance) from sides/ends. Make sure there are no objects resting on or near the solar panels and solar array. Do not deploy GridPak in inclement weather, e.g., high winds or hail.

Before manually deploying the solar tower and array, it is necessary to ensure minimum obstacle clearances and wind speeds — depending on where inspection, maintenance or service is being conducted.

The solar tower and array should be set up in mild conditions, i.e., no heavy sustained winds or gusts of 30 MPH.

- Ensure there is 35 feet of unobstructed clearance above GridPak and that nothing will come in contact with the solar array from above at any angle, under any conditions

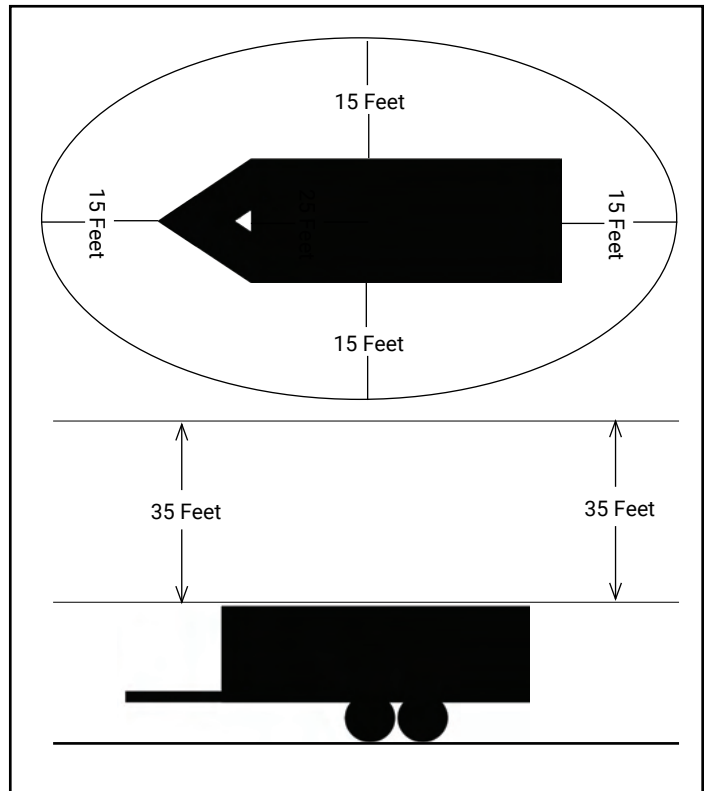

- From the STATUS function tab, press the SETTINGS button to enter manual programming mode



## 7.0 MANUAL PROGRAMMING

### 7.4 Solar Tower/Array Manual Programming

To clean the solar panels or conduct other maintenance or service, it may be convenient and expedient to manually control the solar array and weather tower. Further, there may be occasions when a nearby obstruction (high-rise building) may make deploying and positioning of the array more practical in terms of capturing sunlight.

- From the SETTINGS tab, press the SOLAR DEPLOY tab to enter manual programming

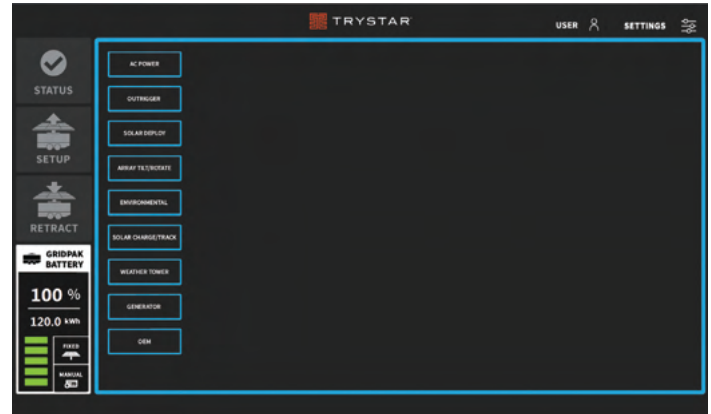

#### 7.4.1 Deploy Solar Array Tower

The solar tower/array screen will open in split-screen format. The tower deployment section is left while the array deployment screen is right. It is necessary to start the hydraulic pump to deploy mast and array.

- Press the ON button to start the hydraulic pump

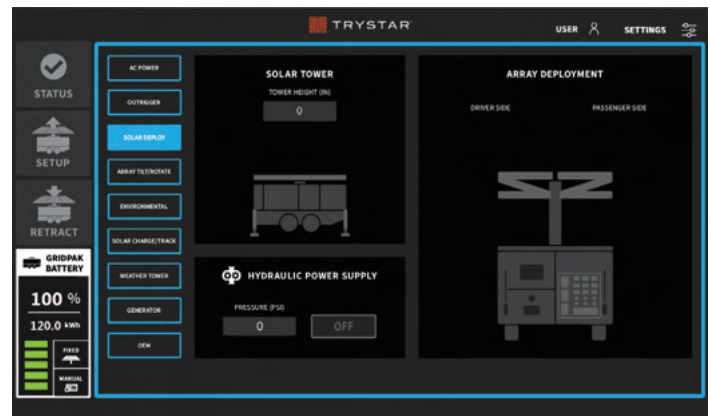

The pump will engage and the button will turn green.

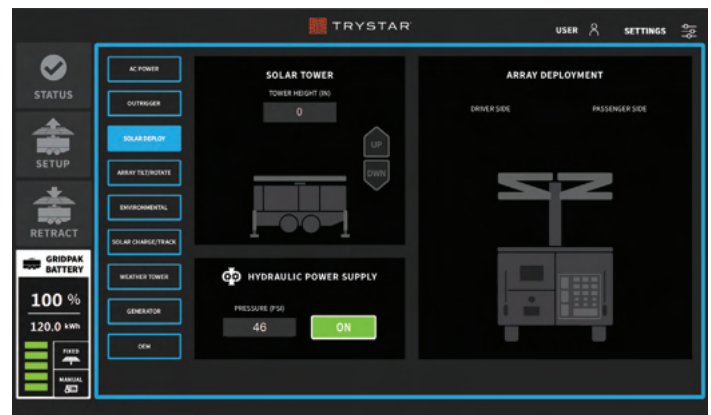

## 7.0 MANUAL PROGRAMMING

### 7.4.1 Deploy Solar Array Tower

- Press the UP button to raise the solar array tower

The tower UP button will turn green and the tower mast start to rise. A warning tone and light will activate to caution any bystanders to stay away as the process unfolds. The operator can start/stop the deployment at any time. The button will return to gray. Until fully elevated, the tower mast will appear in orange. The tower height is expressed in inches as noted in the elevation meter.

The tower mast is a two-part hydraulic cylinder. There will be a slight pause and jerk (normal) when the first cylinder is completely elevated and the second cylinder engages to raise the solar array tower to its full height. The tower is at its fully-extended height when the meter reaches ~59 inches and the tower mast turns green. Once fully elevated, the hydraulic pump will sound louder until the UP button is released. The siren and light will also cease.

**NOTE:** Switch the hydraulic pump OFF before engaging in any inspection or service procedure.

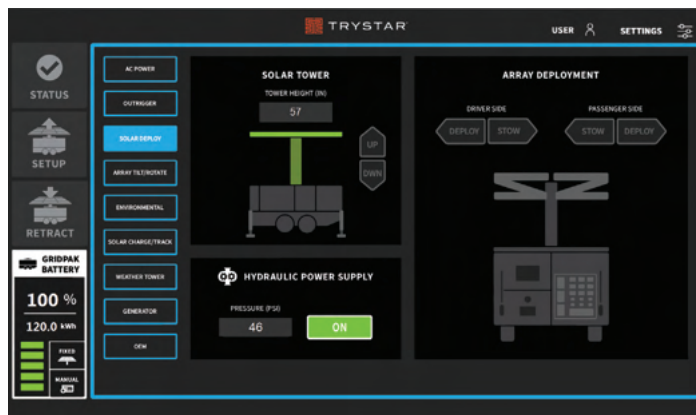
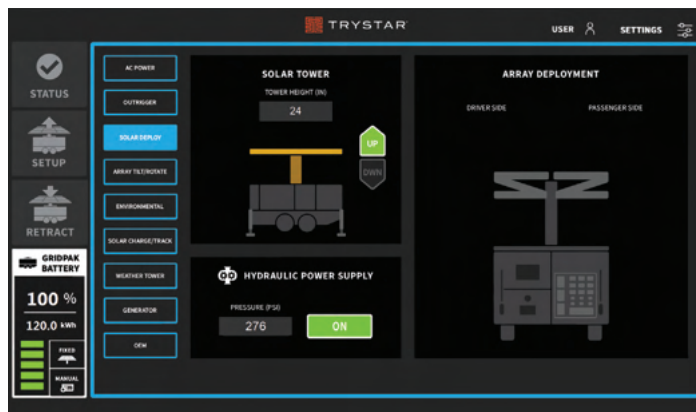

### 7.4.2 Deploy Solar Arrays

- Press the Driver Side DEPLOY button to deploy that side of the solar array

The DEPLOY button will turn green and the panel array orange as the side of the array is deployed. A warning tone and light will activate to caution any bystanders to stay away as the process unfolds. The operator can start/stop the array deployment at any point. The button will return to gray. Until fully elevated, the array will appear in orange.

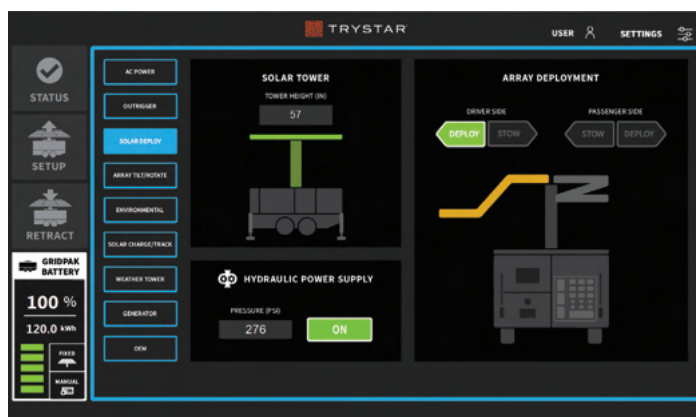

## 7.0 MANUAL PROGRAMMING

### 7.4.2 Deploy Solar Arrays

When the Driver Side solar array is fully deployed, the driver side array will turn green and the warning tone and light will cease. When the DEPLOY button is released, it will return to gray.

**NOTE:** Switch the hydraulic pump OFF before engaging in any inspection or service procedure.

- Press the Passenger Side DEPLOY button to deploy that side of the solar array

The DEPLOY button will turn green and the panel array orange as the side of the array is deployed. A warning tone and light will activate to caution any bystanders to stay away as the process unfolds. The operator can start/stop the array deployment at any point. The DEPLOY button will return to gray.

When the Driver and Passenger Side arrays are fully deployed, the arrays will turn green and the operator can release the UP button. The tone and lights will cease. After shutting the hydraulic pump off, the operator can inspect the array and/or perform maintenance or service.

All panels of the array are also fully available for charging in their present position. Effective charging will depend on the angle and position of the sun.

### 7.4.3 Exiting Programming Mode

- Press the STATUS tab to exit manual programming mode

The display will return to the status home screen.

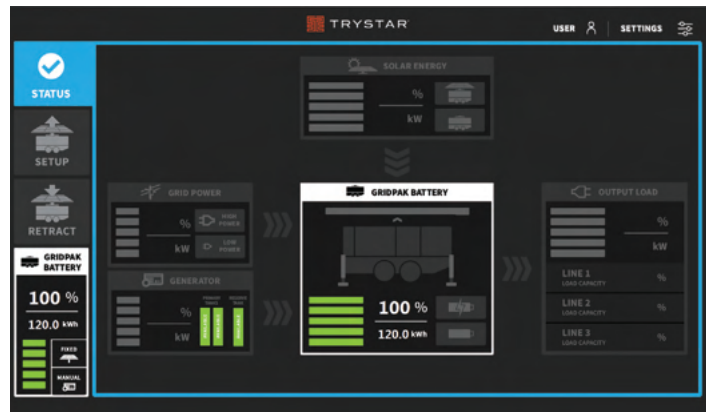
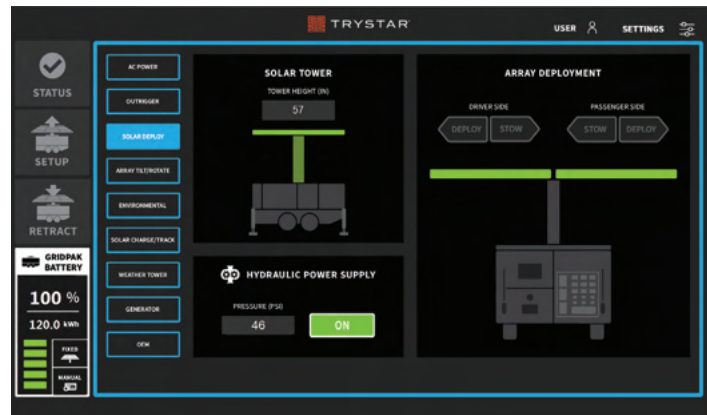
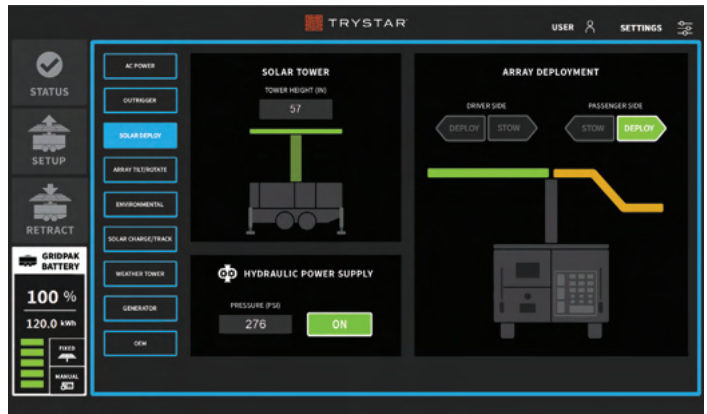
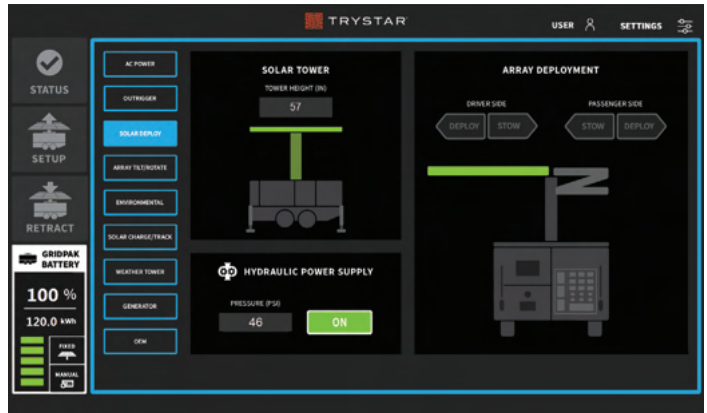

## 7.0 MANUAL PROGRAMMING

### 7.5 Manually Home, Rotate and Tilt Solar Array Functions

#### ⚠ CAUTION

To avoid damaging GridPak during service, it is important to ensure a minimum clearance of 35 feet of unobstructed space from the top of the unit and a minimum of 15 feet of free space (clearance) from sides/ends to allow the solar array to rotate freely. Make sure there are no objects resting on or near the solar panels and solar array. Do not deploy GridPak in inclement weather, e.g., high winds or hail.

To facilitate solar array inspection, maintenance and service, it is possible to manually rotate and tilt the array: **this is only possible after the array tower has been elevated to its full height and the driver and passenger sides of the solar array have been fully deployed.**

Further, to optimize solar charging, there may be conditions in which automatic deployment and solar tracking are not effective or are impractical because of a building or other obstacle blocking the sun. In this scenario, it might be preferable to lock the array at a certain rotation and/or tilt angle to leverage sunlight while possible.

- From the STATUS function tab, press the SETTINGS button to enter manual programming mode
- Press the ARRAY TILT/ROTATE button to enter manual programming for the solar array position

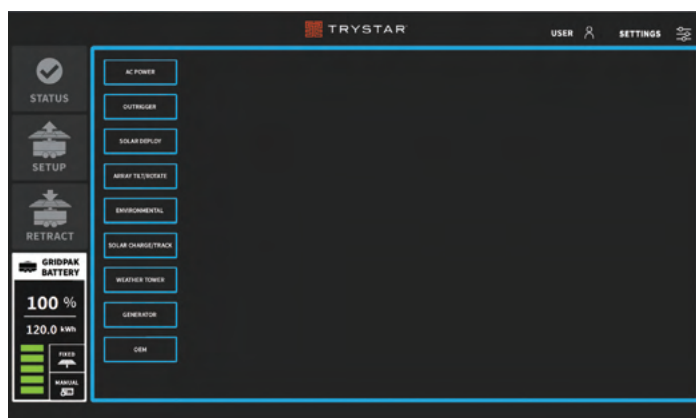
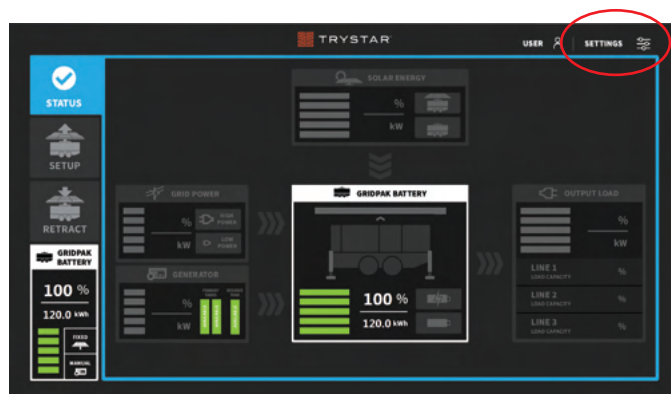

## 7.0 MANUAL PROGRAMMING

---

### 7.5 Manually Home, Rotate and Tilt Solar Array Functions

In order to rotate and tilt to specified parameters and to report precise positions to the operator via the operating system, the GridPak solar array first has to "know" its starting or Home position – relative to the trailer. Further, it has to be in a Homed state for any of the automated features to work such as Go to 0°, solar tracking, and the automated deploy and retract sequences. The Home position is a physical/mechanical position. It has nothing to do with solar tracking or the position of the sun in terms of elevation and azimuth.

When the GridPak array is in the stowed position for transit or storage, the array is folded and flat on top of the trailer in alignment with the trailer's horizontal axis as shown in the adjacent image. The latter is a Home position.

The only time the GridPak can lose its Home position is if it loses all power while the array is elevated. It would need to be charged and then Homed for the automated tasks. It is possible to manually rotate and tilt the array without first Homing it, but it is not recommended.

The GridPak has three home positions for the rotation function. It will find the closest home position and use it to learn its relative position to 0°. The GridPak will also find its Home position for the tilt function and indicate available degrees of shift for it. There is only one Home position for the tilt function.



## 7.0 MANUAL PROGRAMMING

### 7.5 Manually Home, Rotate and Tilt Solar Array Functions

The adjacent screen shows a scenario wherein the GridPak might be deployed for the first time at a new site. The display indicates that the array tower/mast is not fully elevated and the array not fully deployed. Otherwise, a green START button would appear allowing the operator to engage in the Home procedure.

This same scenario indicates GridPak has been "homed" previously and those positions still retained in memory. The tower and array, however, are not fully elevated and deployed. Return to **Section 7.4** and follow the steps to fully deploy the entire array before attempting to adjust the rotate or tilt functions manually.

Once the array tower/mast and solar array are fully deployed, it is possible to home the array. Initially, the screen will show a green START button under Homing Procedure. The indicator immediately adjacent (Status) will be red, indicating the GridPak is not homed. Once homed, the operator can adjust the array position to a determined number of degrees.

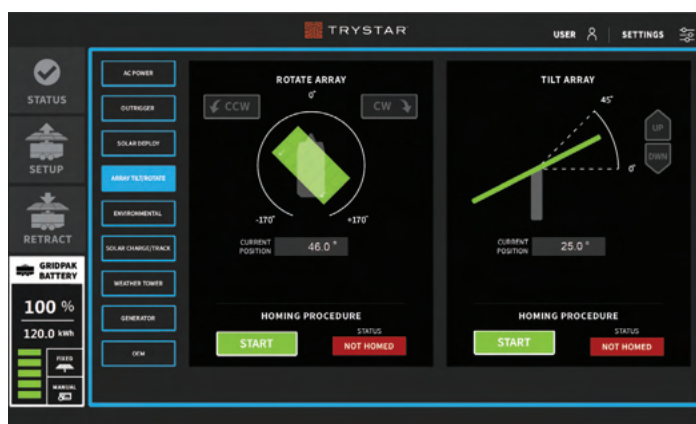
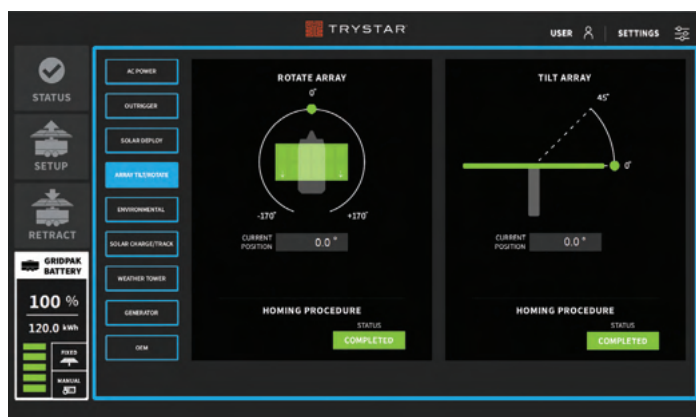
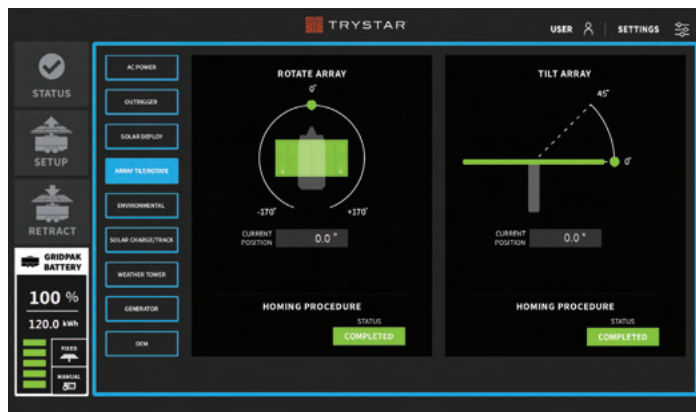

## 7.0 MANUAL PROGRAMMING

### 7.5.1 Home Solar Array for Manual Rotation

- Press the Rotate Array START button to initiate the rotation homing procedure

The GridPak has three rotational home positions relative to the trailer base. It will find the closest home position and use it to learn its relative position to 0°. The display button will be orange and show IN PROGRESS during positioning. Rotation can be stopped at any time in the process if necessary.

When homing is complete for the manual rotation function, the START and STATUS button will be green and STATUS will read COMPLETED.

From this Home position, automated functions will work. It is also possible to manually adjust the degrees of rotation to orient the array horizontally to capture the most solar energy. Obstructions (buildings and shadowed areas) may make this feature necessary. Further, the array can be rotated to a certain position to facilitate inspection, maintenance and service.

**NOTE:** When homing for rotation is completed, Status will say COMPLETED but START will also show. This programming is designed to make it possible to Home the array, rotationally, to either of the other two Home positions. This functionality facilitates access to other Home sensors for inspection or service.

### 7.5.2 Home Solar Array for Manual Tilt

- Press the Tilt Array START button to initiate the tilt homing procedure

The GridPak has one tilt home position relative to the trailer base. It will find the closest home position and use it to learn its relative position to 0°. The display button will be orange and show IN PROGRESS during positioning. Tilting can be stopped at any time in the process if necessary.

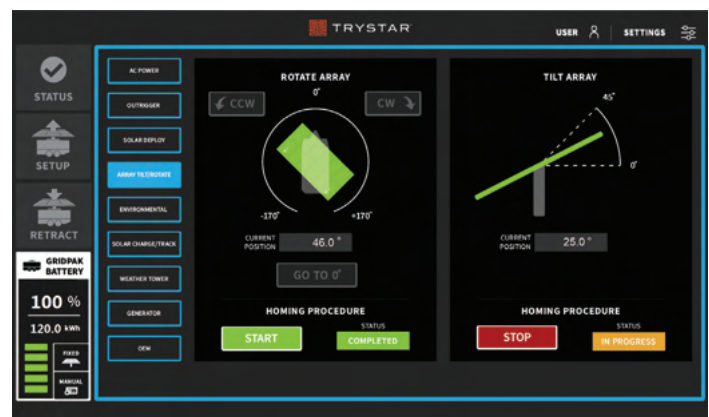
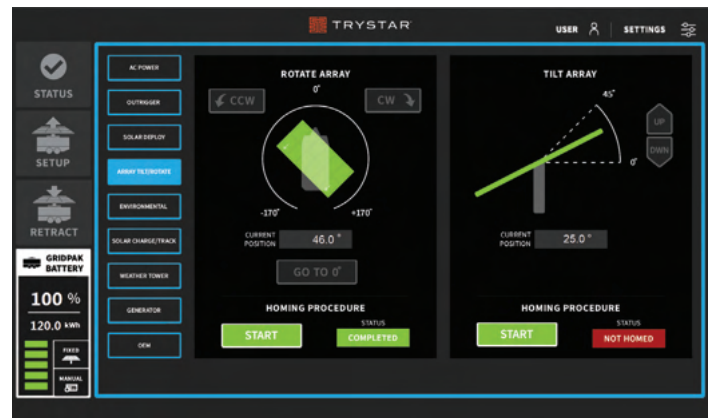
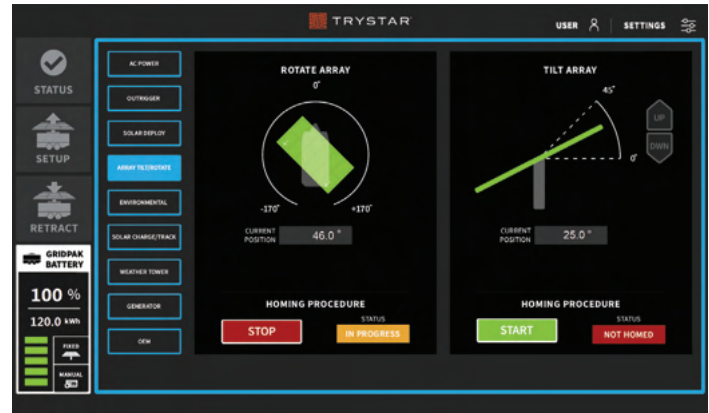

## 7.0 MANUAL PROGRAMMING

### 7.5.2 Home Solar Array for Manual Tilt

When homing is complete for the manual tilt function, the START and STATUS button will be green and STATUS indicator will read COMPLETED.

From this home position, it is possible to manually adjust the angle of declination to orient the array vertically to capture the most solar energy. Obstructions (buildings and shadowed areas) may make this feature necessary. Further, the array can be tilted to a certain position to facilitate inspection, maintenance and service.

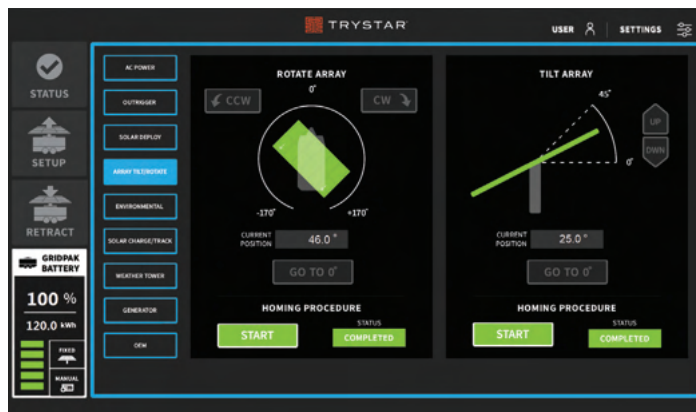

### 7.5.3 Manually Rotate Solar Array

- Press the CCW or CW button to initiate manual rotation
- Stop pressing the CCW or CW button when the desired degree of rotation is reached

The clockwise (CW) and counter-clockwise (CCW) buttons will remain gray until the operator pushes them to rotate the array in either direction. Once a direction button is pressed, it will turn and stay green and the array will rotate as long as the button is pushed or until it reaches its maximum position. These buttons are "momentary" and will always default back to gray when not pressed. The Current Position meter will display the degrees, left or right, from the home position.

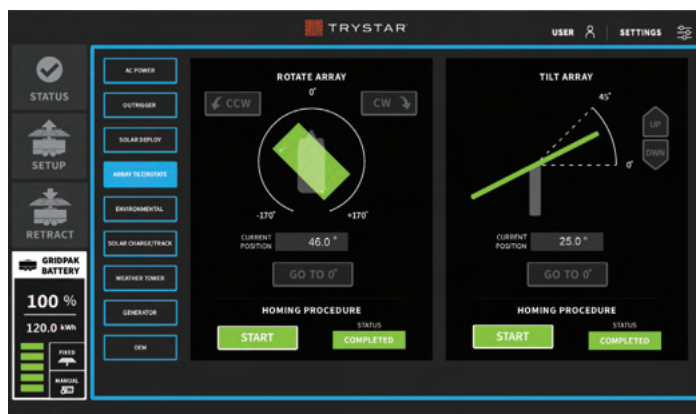
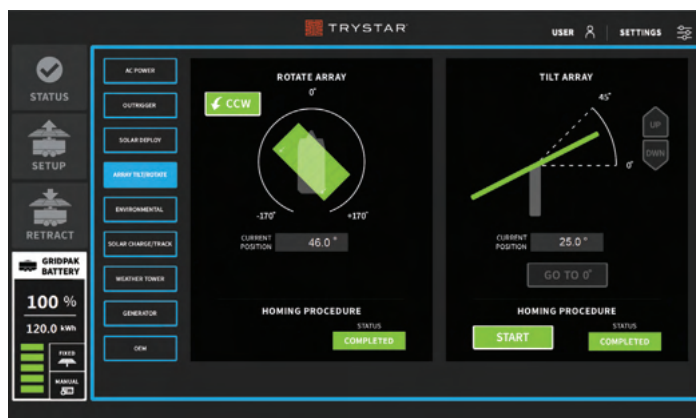

## 7.0 MANUAL PROGRAMMING

### 7.5.4 Manually Rotate Solar Array for Stowage

The rotate array display also features a GO TO 0° button. When homed and regardless of the array's position, the operator can press the GO TO 0° button to return the array to the stowage position where the array can be folded and the mast/tower lowered for transit. This position is also commonly used for inspection, maintenance or service.

- Press the Rotate Array GO TO 0° button to prepare the array for inspection, maintenance, service or stowage and transit

When the GO TO 0° button is pressed, Status stays the same. The START, CCW and CW buttons will be hidden but reappear when 0° is reached.

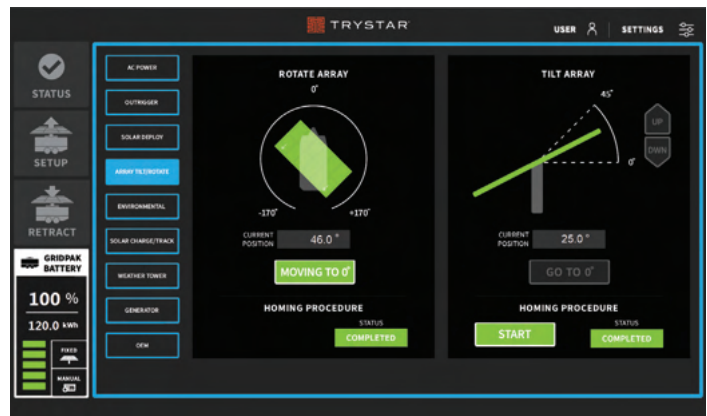

### 7.5.5 Manually Tilt Solar Array

Once homed, the array will be in a flat or horizontal position parallel to the ground.

- Press the Tilt Array UP button to initiate manual tilt
- Stop pressing the Tilt Array UP button when the desired degree is reached
- Press and release the Tilt Array DOWN button to make additional adjustments or to return the array to the horizontal position



## 7.0 MANUAL PROGRAMMING

### 7.5.5 Manually Tilt Solar Array

The Tilt Array UP and DOWN buttons will remain gray until the operator pushes them to tilt the array in either direction. Once a direction button is pressed, it will turn and stay green and the array will tilt as long as the button is pushed or until it reaches its maximum position.

When the operator reaches the desired angle and releases the Tilt Array UP or DOWN buttons, the Current Position meter will display the angle in degrees from the horizontal position. The UP and DOWN buttons will turn to gray and the Homing Procedure buttons will turn green and indicate START and COMPLETED.



### 7.5.6 Manually Tilt Solar Array for Stowage

There is one manual method of returning the solar array to the horizontal position to prepare it for stowage and transit or to capture sunlight if desired. The operator can press the GO TO 0° button.

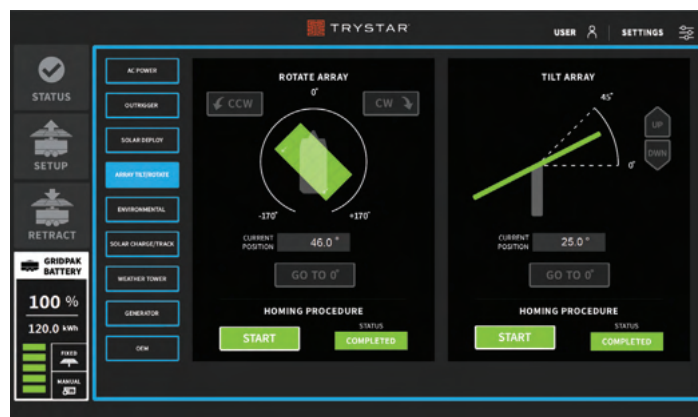

- Press the Tilt Array GO TO 0° button to return the solar array to its fully horizontal position to capture sunlight or for stowage and transit

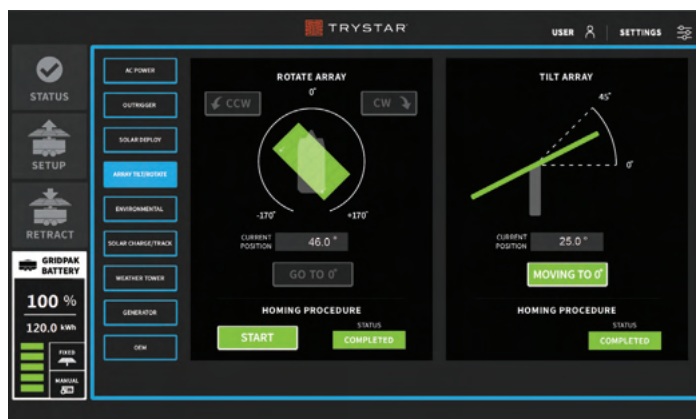

## 7.0 MANUAL PROGRAMMING

### 7.5.7 Exiting Programming Mode

- Press the STATUS tab to exit manual programming mode

The display will return to the status home screen.

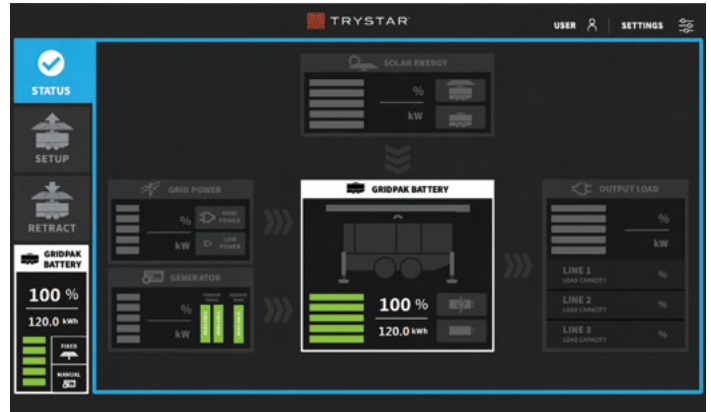

## 7.0 MANUAL PROGRAMMING

### 7.6 Manually Monitor Environmental Functions

For optimum operation, it may be prudent to monitor the GridPak batteries in extremely hot or cold weather. The GridPak has banks of lithium-iron phosphate (LiFePO<sub>4</sub>) batteries which are used to store energy and power downstream electrical devices. The GridPak has other conventional lead-acid batteries to support the GridPak trailer lighting and operating system. Another battery is used to warm and start the LP onboard auxiliary power generator.

The GridPak is programmed to automatically enable heating and cooling and otherwise open and close vents as necessary. The manual programming functionality is primarily designed for the operator to monitor conditions and discern when service may be necessary.

A list of general operating temperature ranges is shown below.

Acceptable GridPak Operating Temperatures and Conditions	
Solar Charger Enclosure	-20°F – 140°F
Generator	-20°F – 140°F
Inverter	-20°F – 140°F
LiFePO <sub>4</sub> Battery Banks (Charging and Discharging)	32°F – 110°F
LiFePO <sub>4</sub> Battery Front Enclosure (Idle)	5°F – 120°F
Lead-Acid System and Generator Batteries	-20°F – 140°F
Controls	-20°F – 140°F
AC Distribution	-20°F – 140°F
Outside	-20°F – 140°F
Wind Speed	<50 MPH When Fully Deployed*

\*Do not deploy GridPak in windy (>15 MPH) or other inclement weather conditions (rain, snow, hail, sleet, etc.). It can only tolerate higher winds (<50 MPH) when fully deployed.

## 7.0 MANUAL PROGRAMMING

### 7.6 Manually Monitor Environmental Functions

- From the STATUS function tab, press the SETTINGS button to enter manual programming mode

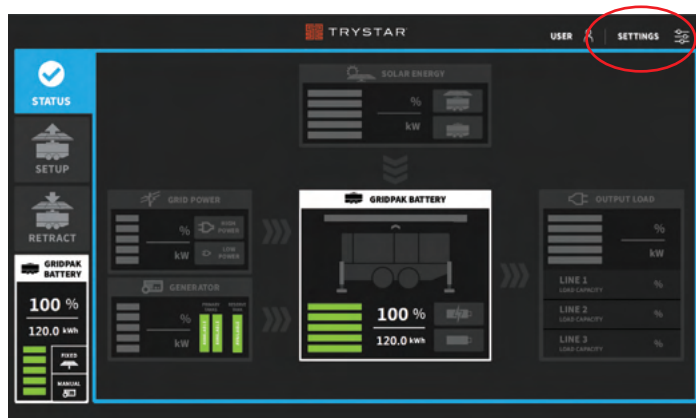

- Press the ENVIRONMENTAL tab to enter manual programming

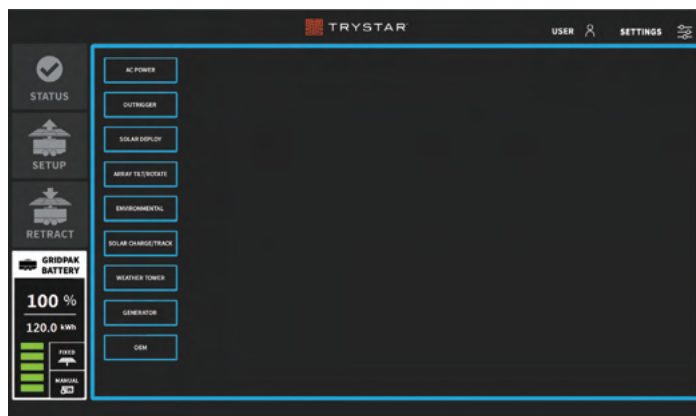

The Environmental Controls & Sensors screen is largely for monitoring conditions. The Automatic Climate Control button should be enabled as it automates both cooling (chillers) and heating.

The most critical metrics pertain to the LiFePO<sub>4</sub> enclosure. The temperatures of the batteries and the enclosure are shown in the metrics at the left side (Battery Enclosure) of the display. The indicators also show if the circulation fans, vents, chiller or heater are activated. The Automatic Climate Control button should be green and ON in most scenarios other than inspection, maintenance or servicing of individual components.

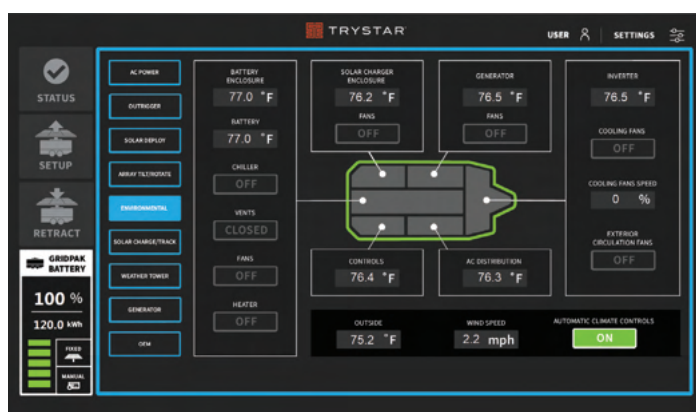

## 7.0 MANUAL PROGRAMMING

### 7.6 Manually Monitor Environmental Functions

To perform any inspection, maintenance or service to the environmental systems while the GridPak is deployed, all the systems must be turned off.

- Press the Automatic Climate Control button OFF

All the control buttons will be CLOSED or OFF, including the Automatic Climate Control button.

The temperature range of the Battery Enclosure should be 32°F – 110°F when charging and/or powering devices downstream. Otherwise, -5°F – 120°F is an acceptable temperature range. The vents open and the circulation fan is activated if the batteries are charging/discharging and temperatures exceed 90°F. If the battery compartment reaches 104°F, the vents will close and the fans and chiller will activate.

In colder weather, the heater and circulation fan will activate and vents close when the batteries are charging/discharging and temperatures are <50°F. Otherwise, the heater and circulation fan will turn on and vents close when temperatures are <14°F.

When Automatic Climate Control is ON the operator will be able to see if the appropriate devices (indicated by ambient temperatures) are operating correctly and temperatures are being maintained within an acceptable range. Otherwise service may be required.

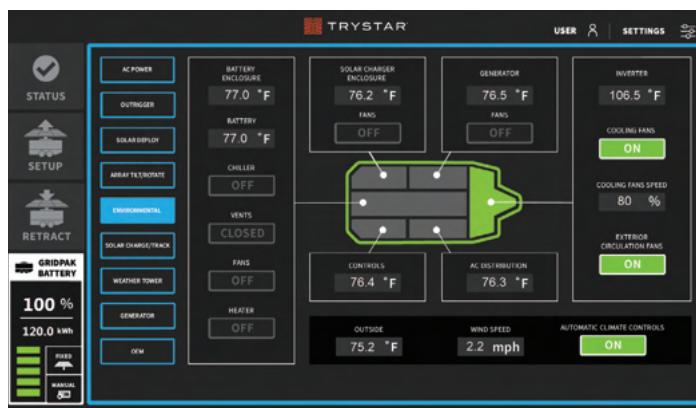
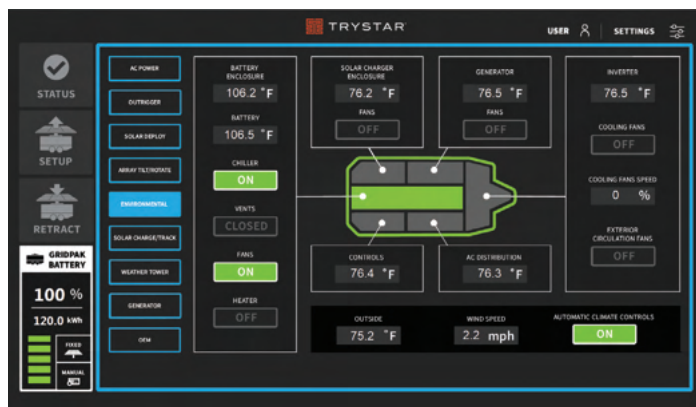
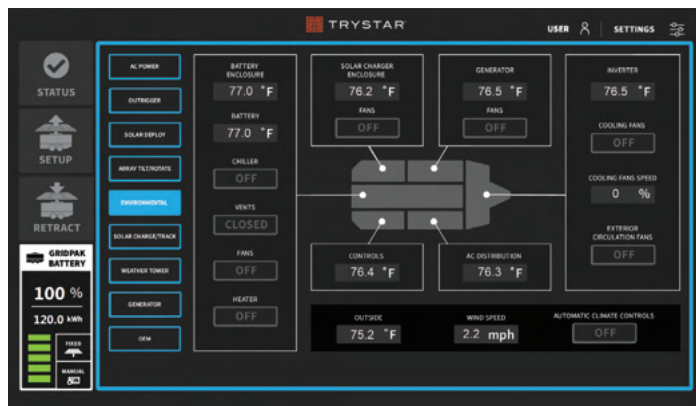

## 7.0 MANUAL PROGRAMMING

### 7.6 Manually Monitor Environmental Functions

The inverters also generate heat when active but they are less operationally sensitive to conditions compared to the battery bank enclosures. The top center section of the display shows Solar Charger and Generator enclosure temperatures and their mediation status.

Normal inverter operating temperatures are  $-20^{\circ}\text{F} - 140^{\circ}\text{F}$ . The circulation fan activates when the inverter is on or temperatures exceed  $90^{\circ}\text{F}$ . Cooling fans activate if the inverter is inputting/outputting  $> 2 \text{ kW}$  and the speed ramps up as power increases — shown in Inverter Fans Duty measured as a percent.

The normal Solar Charger Enclosure temperature range is  $-20^{\circ}\text{F} - 140^{\circ}\text{F}$ . The circulation fan will turn on when solar charging is active or the enclosure temperature exceeds  $90^{\circ}\text{F}$ .

The lower center section of the Environmental Controls and Sensors display shows ambient temperatures and wind speed. The ambient temperature and wind conditions help the operator make deploy/don't deploy decisions.

The normal Generator temperature range is  $-20^{\circ}\text{F} - 140^{\circ}\text{F}$ . The circulation fan will turn on when generator charging is active or the enclosure temperature exceeds  $90^{\circ}\text{F}$ .

The Controls Enclosure temperature is important in cold conditions. The LCD display is vulnerable in extremely cold ( $< -20^{\circ}\text{F}$ ) conditions and should not be allowed to get this low.

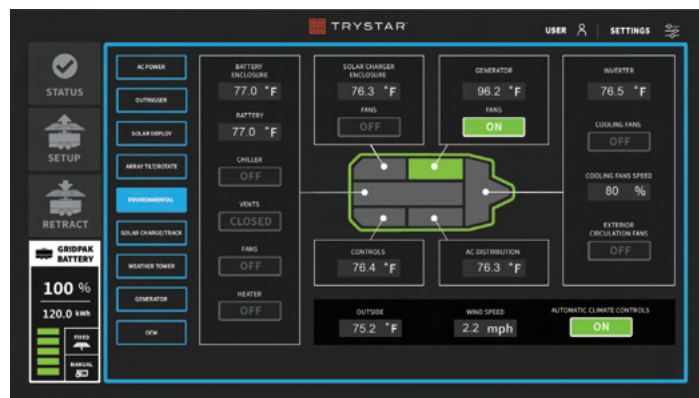
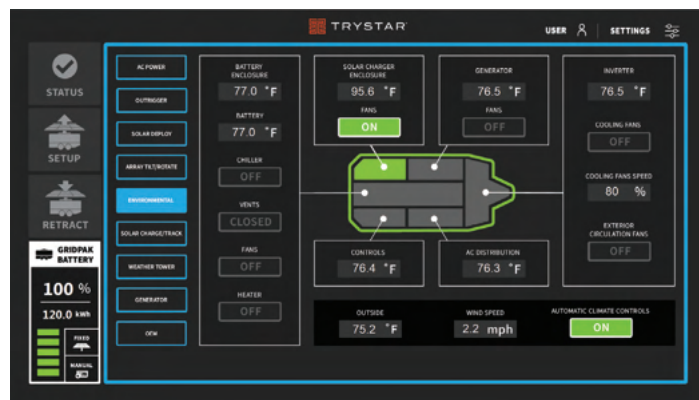
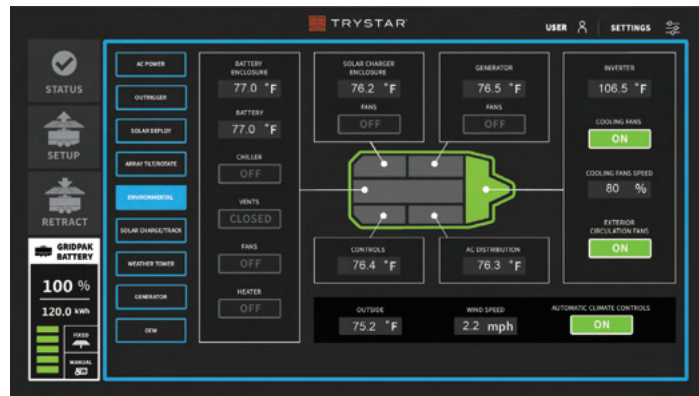

## 7.0 MANUAL PROGRAMMING

### 7.6.1 Exiting Programming Mode

- Press the STATUS tab to exit manual programming mode

The display will return to the status home screen.

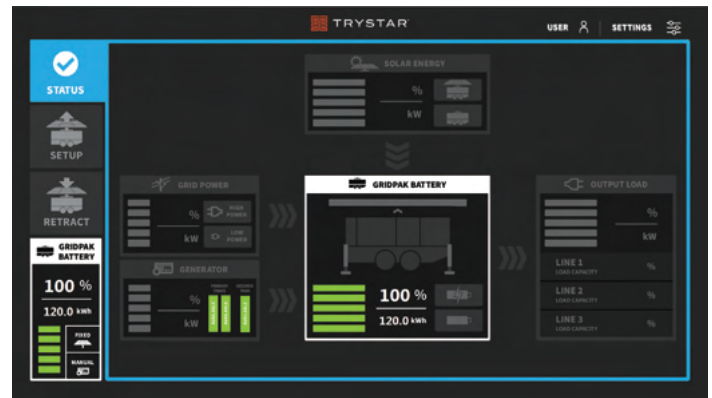

## 7.0 MANUAL PROGRAMMING

### 7.7 Manually Program Solar Tracking and Charging

The solar tracking programming feature allows the operator to view the operation of the solar tracking function to ensure it is working properly. It also allows the operator to stop tracking in order to inspect or service the array when deployed. Similarly, the manual charging feature allows the operator to turn charging on or off for service-related tasks, but also to tie in supplemental solar charging resources.

- From the STATUS function tab, press the SETTINGS button to enter manual programming mode
- Press the SOLAR CHARGE/TRACK button to access programming

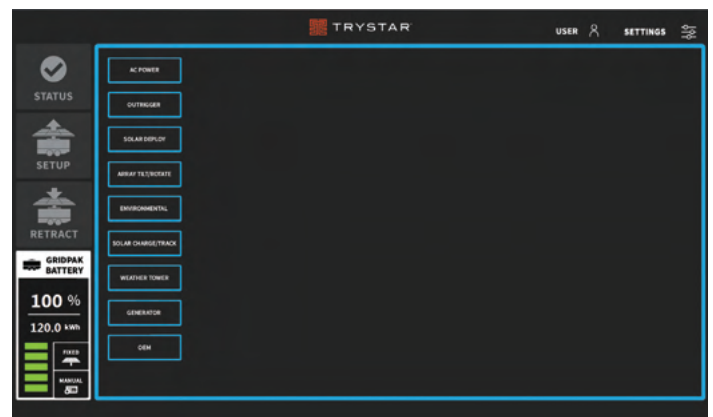
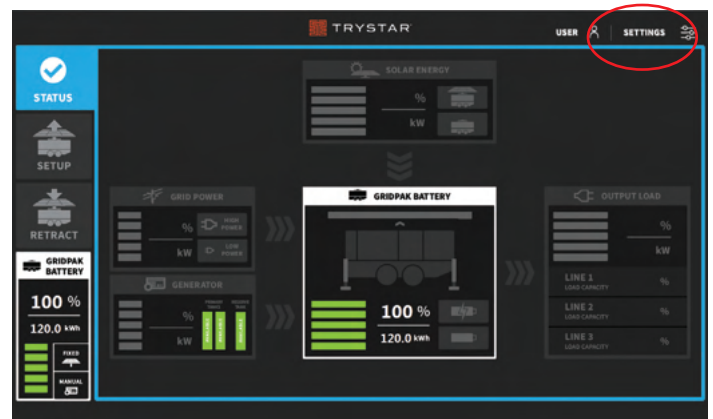

## 7.0 MANUAL PROGRAMMING

### 7.7.1 Manually Program Solar Tracking

The SOLAR CHARGE/TRACK display consists of a split screen. The left side is dedicated to solar tracking data and control. The right side controls charging and charging options.

The Solar Tracking Control split screen provides the operator with a variety of information. One of the meters indicates the number of satellites the GridPak is using to guide its solar array. It is programmed to use four satellites to optimize tracking and charging. Three satellites is acceptable. Without access to three satellites, the automatic tracking function will not be available. The operator can try moving the GridPak (within reason) on the work site to acquire proper satellite coverage.

The other meter toward the top indicates whether tracking is enabled – an option when being automatically deployed. Automatic solar tracking is **not** the default in a conventional GridPak deployment. The ON/OFF button (grayed out when off) for Solar Tracking allows the operator to stop tracking to conduct inspection, maintenance or service. When tracking is re-enabled, following an operational pause, the GridPak will reacquire satellite coverage and reorient itself to the sun.

- Press the Solar Tracking button OFF to engage in inspection, service or maintenance

**NOTE:** The GridPak operating system is always searching for satellite coverage. The number of satellites will always be shown whether automatic solar tracking function is engaged or not engaged.

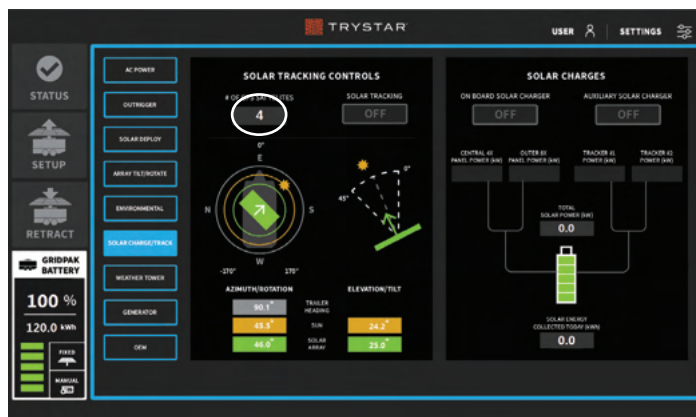
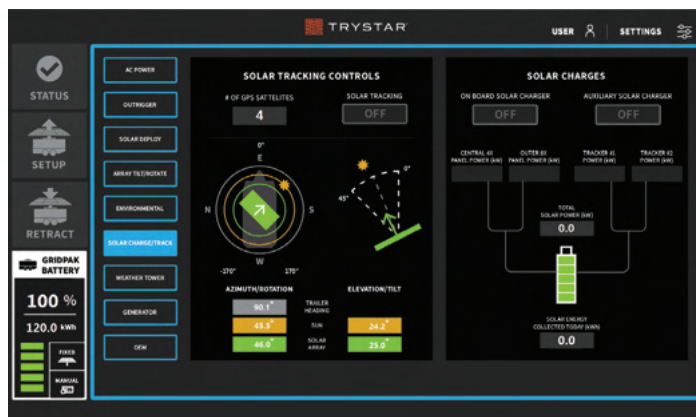
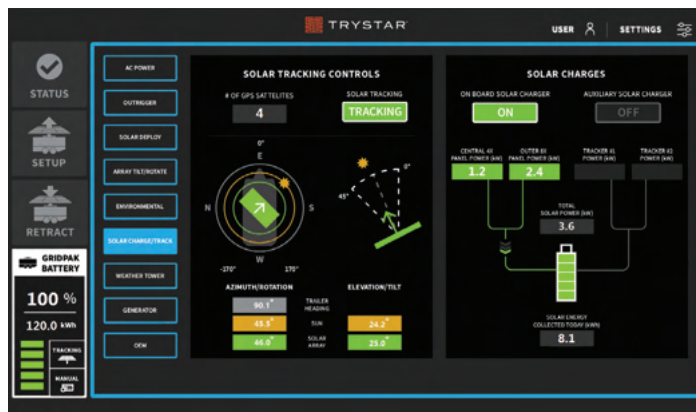

## 7.0 MANUAL PROGRAMMING

### 7.7.1 Manually Program Solar Tracking

- Press the Solar Tracking button ON to re-engage solar tracking

When maintenance or service is concluded, the operator can press the Solar Tracking ON button to resume tracking. The button will turn green. The rotation and tilt may change depending on the duration of the pause.

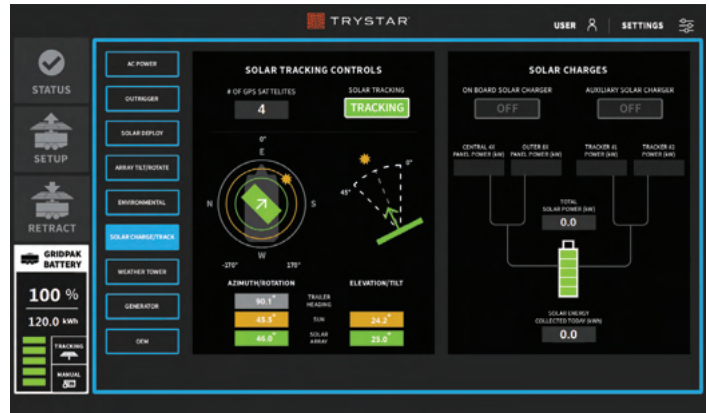

### 7.7.2 Solar Tracking Control Meter Interpretation

Two graphics on the left side of the split screen indicate rotation and elevation status. The first of these consists of concentric circles and the second, an angle reading.

#### 7.7.2.1 Azimuth/Rotation Interpretation

The color of the concentric circles at right correspond with the like-colored boxes below them. The primary actionable data from these meters is to ensure that when in automatic solar tracking mode, the GridPak array follows the sun. If it does not, then service is required.

An azimuth is the angular measurement in a spherical coordinate system which represents the horizontal angle from a cardinal direction, most commonly north. In this case, the figure contained within the gray box indicates the front of the trailer is pointed almost directly east (90.1°) on the gray circle which shows true north.

The figure in the gold box indicates the position of the sun, relative to the trailer front-to-back axis. In this case, the sun is at 45.5° and the solar array (green box with arrow) is pointed at 46.0° – tracking the sun in this moment.

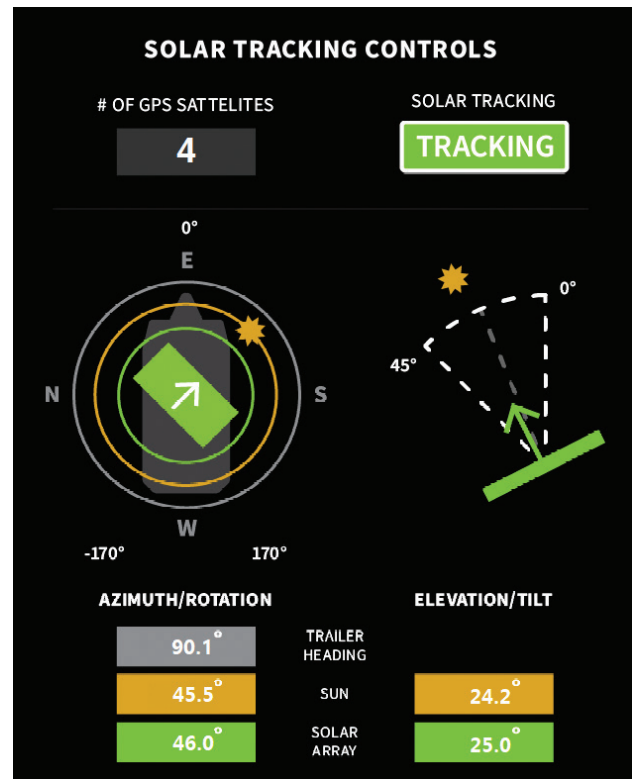

## 7.0 MANUAL PROGRAMMING

### 7.7.2.2 Elevation/Tilt Interpretation

The figure in the gold Sun box and the sun graphic pictured in the adjacent picture show the sun's elevation at 24.2°. The figure in the green Solar Array box reads 25.0°. Correspondingly, the green arrow pointed along the sun's travel arc also indicates 25.0°. (The GridPak's solar array is tilted toward the sun.) For optimum charging, the solar array should be tilted toward the sun and very close to 24.2°. This elevation will obviously change throughout the day.

**NOTE:** The primary purpose of the solar tracking controls screen is for monitoring the performance of the GridPak solar array tracking function. When functioning properly, the sun and solar array rotation and sun elevation and array tilt should be approximately the same.

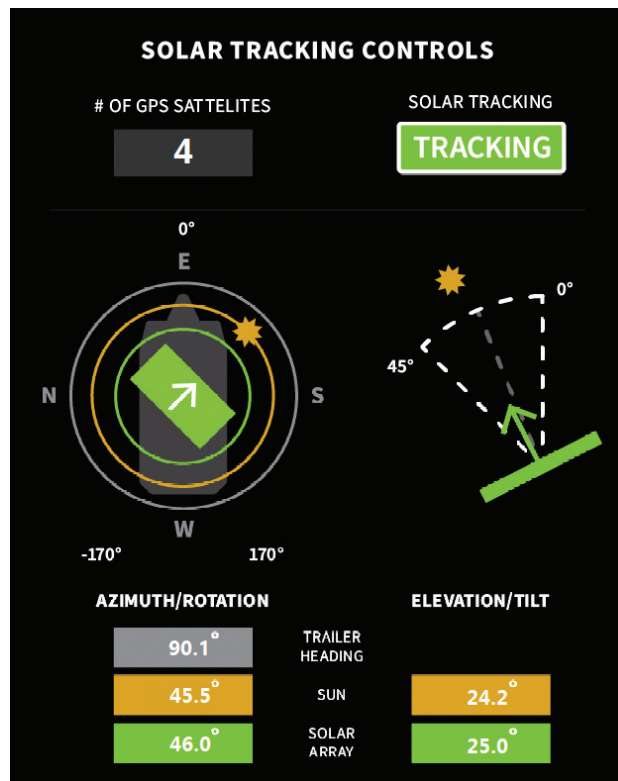

### 7.7.3 Manually Program Solar Charging

The Solar Charge/Track split screen allows the operator to enable and disable the GridPak's solar charging function, facilitating charging system inspection, maintenance and service as necessary. It also provides the ability for the GridPak to receive supplemental charging from a separate bank of solar arrays. Service or maintenance needs may necessitate disabling the tracking function as well.

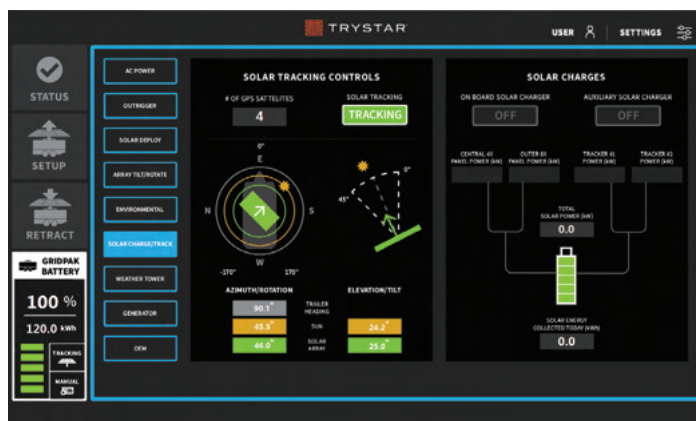

#### 7.7.3.1 Enable Manual Solar Charging

- Press the Solar Charging button ON to enable manual GridPak solar array charging

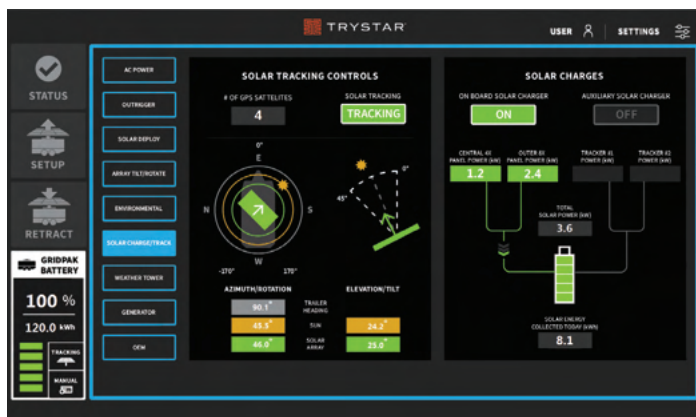

## 7.0 MANUAL PROGRAMMING

### 7.7.3.1 Enable Manual Solar Charging

With solar charging enabled, the ON button will be green and the display will reveal the amount of power the array is generating (kW) from the inner and outer set of array panels.

If only four panels are deployed, the Central 4X button will turn green and show the charge expressed in kW. The Outer 8x button will also turn green but will show a 0.0 kW charge level. If all twelve panels are deployed, the Outer 8X button will show charging expressed in kW.

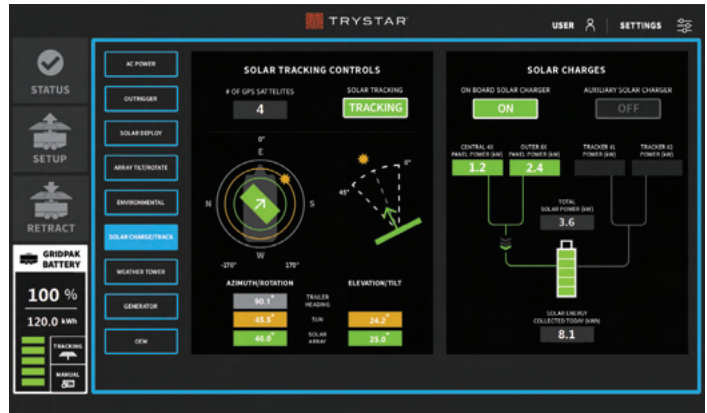

4 Panels Deployed

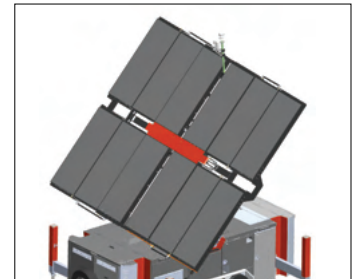

12 Panels Deployed

The Total Solar meter indicates the aggregate charge coming from the GridPak solar panels.

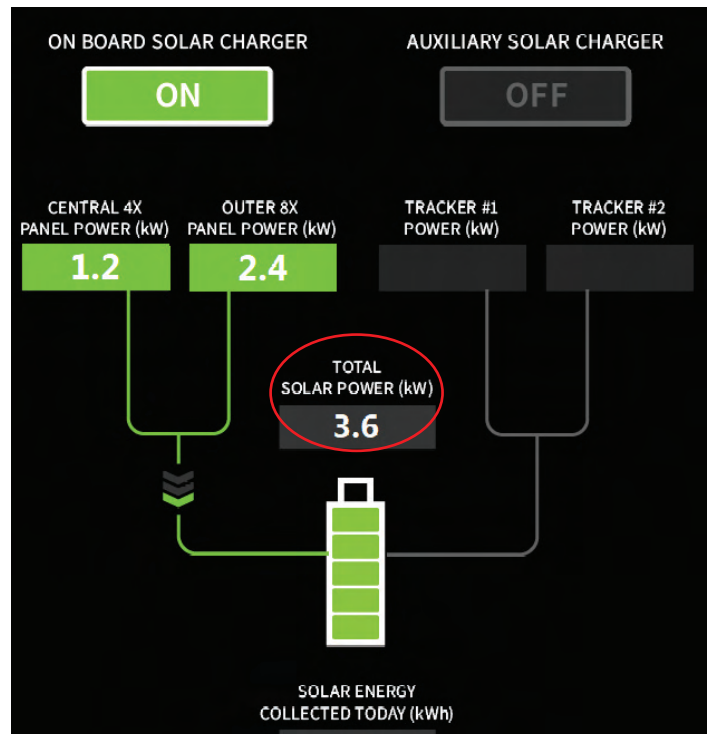

## 7.0 MANUAL PROGRAMMING

### 7.7.4 Enable Manual Auxiliary Solar Charging

The GridPak is designed to accommodate charging from external solar arrays using standard MC4-type connections.

In the load input panel on the side of the GridPak there are connection points for two external solar array inputs. Once the external connections are made, it is possible to enable them from the Manual Solar Charging screen.

Each input has three connections: DC+, DC- and Ground. The DC+ terminal accepts an Amphenol #H4SMM4DM, MC4 Panel Connector, Male, 12 AWG. The DC- and Ground terminals accept an Amphenol #H4SFM4DM, MC4 Panel Connector, Male, 12 AWG. Any external solar connections would need to use connectors that are compatible.

The associated specifications are shown in the chart below.



Auxiliary Solar Connection Specifications	
Maximum DC PV Voltage	450 V
Start-up Voltage	120 V (Panel must reach 120 V for charger to start pulling power)
Operating Voltage Range	80 - 450 V (Once panels reach 120 V, they can drop to 80V afterward)
Maximum PV Operational Input Current	18 A (Per Input)
Maximum PV Short Circuit Current	20 A (Per Input)
Maximum DC Output Charging Power	4000 W Per Input (Max. 5760 W between 2 inputs)

## 7.0 MANUAL PROGRAMMING

### 7.7.4 Enable Manual Auxiliary Solar Charging

- Press the Auxiliary Solar Charger button ON to enable external GridPak solar array charging

The top Auxiliary Solar Charger button will change to green. If two external solar charging sources are connected, both Tracker #1 and Tracker #2 buttons will turn green and charging will be expressed in kW from each respectively. If only one external input source is connected, both Tracker Power #1 and #2 meters will still turn green but the Tracker #2 meter will show 0.0 kW. The Total Solar Power meter will reflect charging expressed in kW from either or both Onboard Solar Chargers and either or both Auxiliary Solar Chargers, i.e., Tracker #1 and/or Tracker #2. .

When both the GridPak and its Auxiliary Solar Charging sources are connected, the total amount of charging (kW) will be reflected in the corresponding charge meters.

The Solar Energy Collected in a 24-hour period is captured in the bottom meter and is expressed in kWh.

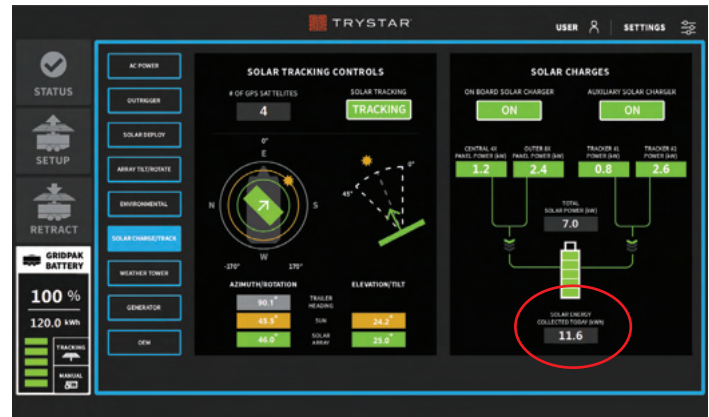

### 7.7.5 Exiting Programming Mode

- Press the STATUS tab to exit manual programming mode

The display will return to the STATUS home screen.

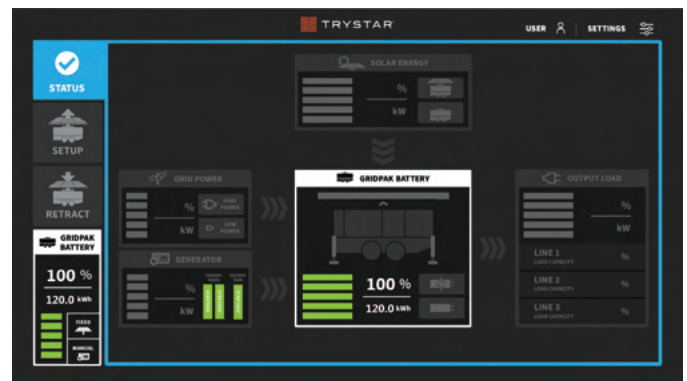

## 7.0 MANUAL PROGRAMMING

### 7.8 Manually Program Weather Tower

It is possible to stow and then re-deploy the GridPak weather tower for inspection, service and maintenance, regardless of whether the array is deployed or stowed. When the array is deployed, stowing the weather tower can facilitate service to the solar panels/array and other GridPak components. Stowing the tower also provides additional ceiling clearance should it be required.

The GridPak's weather tower captures ambient temperature and wind speed. Ambient temperature can affect operation and environmental systems. A primary function of the tower, however, is to protect the GridPak and its solar array from potential wind damage. **The default status of the Automatic Array Retraction function is ENABLED.** If winds exceed 50 MPH, the GridPak solar array will tilt to a horizontal (parallel to the ground) position to prevent damage to the solar panels and the deployment mechanism. It is important that the Automatic Array Retraction function remain enabled other than for service. Access the Weather Tower screen from the Settings screen.

#### ⚠ CAUTION

To avoid damage to GridPak's solar panels and solar array deployment mechanism, always re-enable the Automatic Array Retraction function in the Weather Tower tab after performing an inspection, service or maintenance.

- From the STATUS function tab, press the SETTINGS button to enter manual programming mode

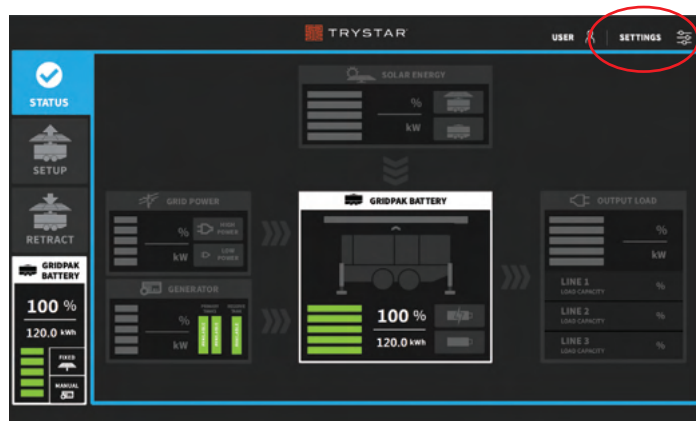

## 7.0 MANUAL PROGRAMMING

### 7.8 Manually Program Weather Tower

- From the SETTINGS screen, press the WEATHER TOWER button to access weather tower manual programming



The WEATHER TOWER split screen displays the position of the tower relative to the solar array and the trailer (vertical) on the left side. Weather conditions are shown on the right side. The weather tower itself is graphically shown in green and the array in gray.

There are two meters at the bottom of the Weather Tower display. The top meter (green box) shows the weather tower angle in degrees relative to the trailer, assuming it is on flat ground. The default position is vertical – zero degrees – relative to the ground or trailer. The bottom meter (gray box) shows the angle of the tower relative to the solar array panels.

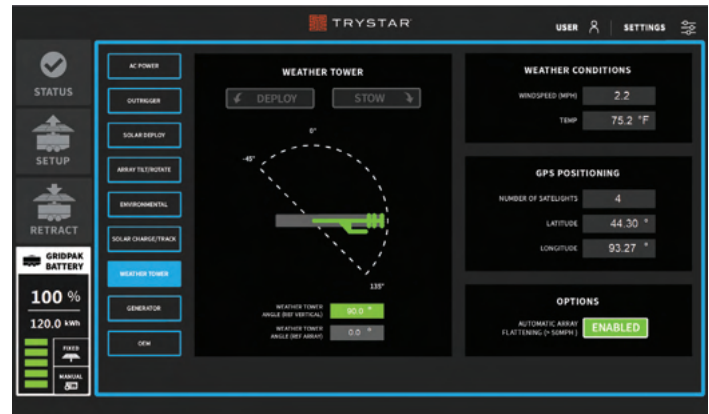

#### 7.8.1 Manually Stow Weather Tower

- Press STOW to retract the weather tower to its home position

The STOW button will turn green while the button is pressed and the tower folds. The angle meters will reflect the change relative to both trailer and array positions.

Hold the button down until it reads 0° in the Weather Tower Angle (Ref Vertical) indicator or until it stops. When the button is released it will return to gray.

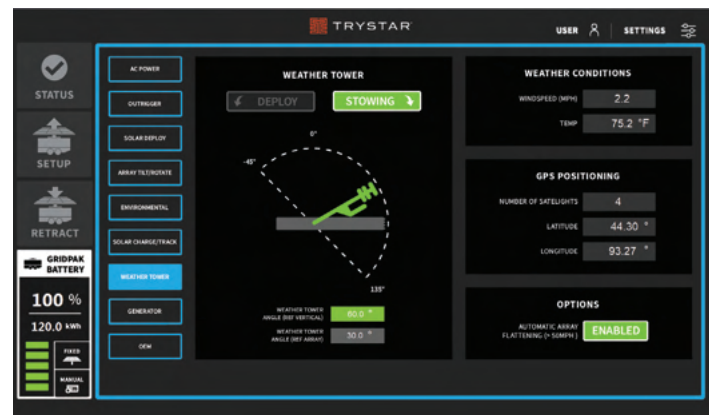

## 7.0 MANUAL PROGRAMMING

### 7.8.2 Manually Deploy Weather Tower

- Press DEPLOY to raise the weather tower to its home position

The DEPLOY button will remain green while the button is pressed and the tower unfolds. The angle meters will reflect the change relative to both trailer and array positions. The button will return to gray when released.

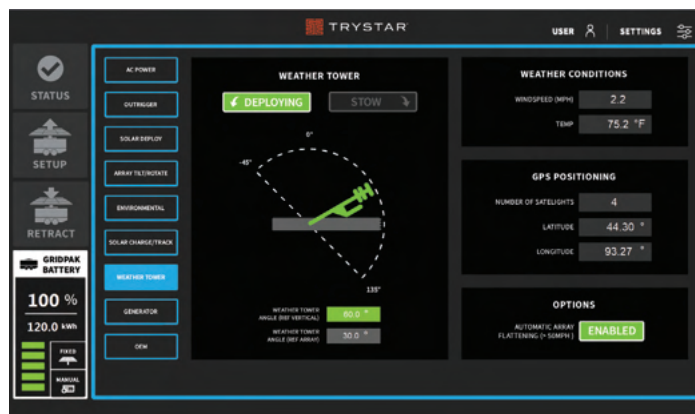

### 7.8.3 Manually Monitor Wind Speed

Accessing the WEATHER TOWER function allows the operator to check the ambient temperature and review wind speeds.

The Weather Conditions side of the split screen shows current wind speed in the top meter.

If winds exceeded 50 MPH and the Automatic Array Retraction feature was enabled, the GridPak (if deployed) array would have moved to a horizontal (parallel to ground) position.

In inclement (windy or stormy) weather or if inclement weather is expected, it is possible for the operator to deploy the weather tower without the array, to check wind speed. The information can inform a deployment/no deployment decision.

The GridPak should not be deployed in windy conditions. Once up (in calm conditions) it can tolerate wind speeds under 50 MPH.

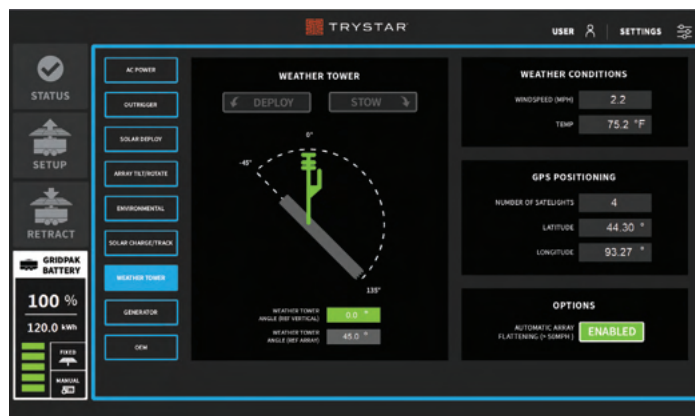

## 7.0 MANUAL PROGRAMMING

### 7.8.4 Manually Monitor Temperature

The Weather Conditions side of the split screen also shows current ambient temperature. The purpose of the thermometer is to help the operator determine if the GridPak will be operated within safe parameters as noted in **Section 7.6**. Extreme temperatures will affect the performance of the GridPak and influence the operation of environmental systems. The GridPak should be operated within acceptable limits to avoid damage and facilitate optimal performance.

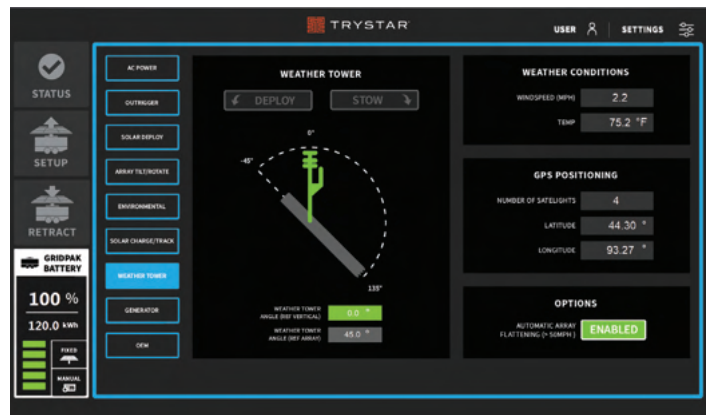

#### ⚠ CAUTION

To avoid damage to GridPak's solar panels and solar array deployment mechanism, always re-enable the Automatic Array Retraction function in the Weather Tower tab after performing an inspection, service or maintenance.

### 7.8.5 Manually Disable Automatic Array Retraction

It is possible to disable the Automatic Array Retraction feature but it is not advisable. One reason to disable it would be if it needs to be calibrated or is malfunctioning. If malfunctioning, the GridPak should be taken out of service and the weather tower repaired or replaced.

If operation is compulsory and the operator knows wind conditions will not exceed 50 MPH during the scheduled deployment period, the GridPak can be operated until such time as the weather tower can be repaired or replaced. This is not advisable nor will Trystar warranty the GridPak under these conditions.

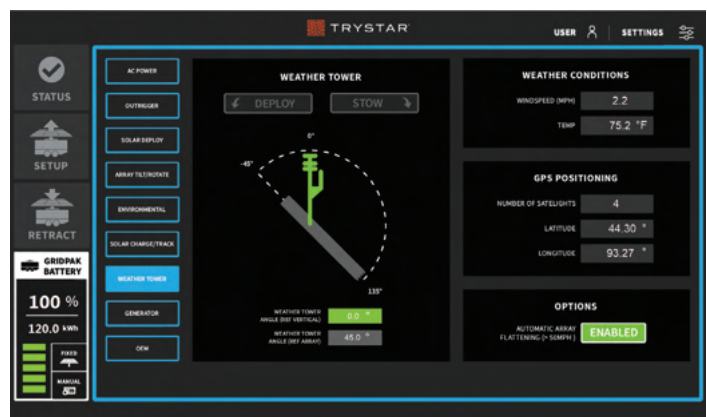

- Press DISABLE to stop the Automatic Array Retraction function

The DISABLE button will turn gray and the label will read Disabled.

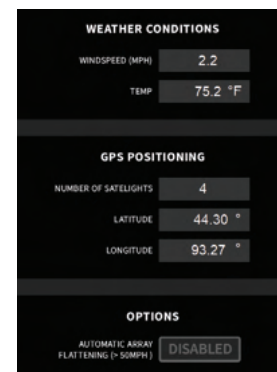

## 7.0 MANUAL PROGRAMMING

### 7.8.6 Enable Automatic Array Retraction

- Press the DISABLED button in the Weather Conditions Option screen to re-enable Automatic Array Retraction function

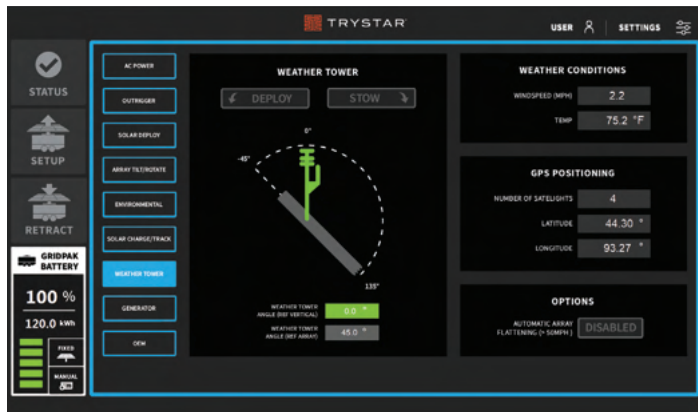

The button will turn green and read ENABLED.

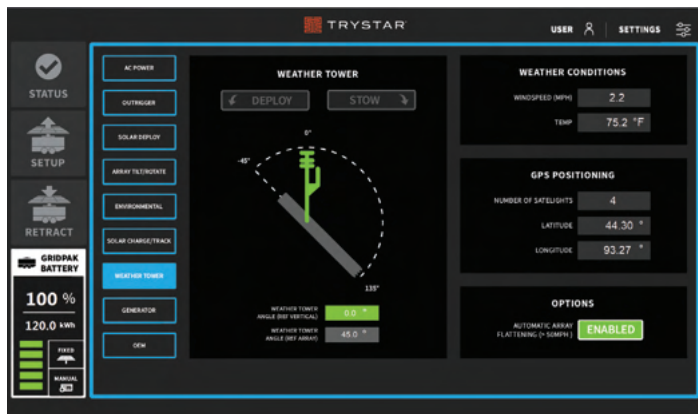

### 7.8.7 Exiting Programming Mode

- Press the STATUS tab to exit manual programming mode

The display will return to the status home screen.

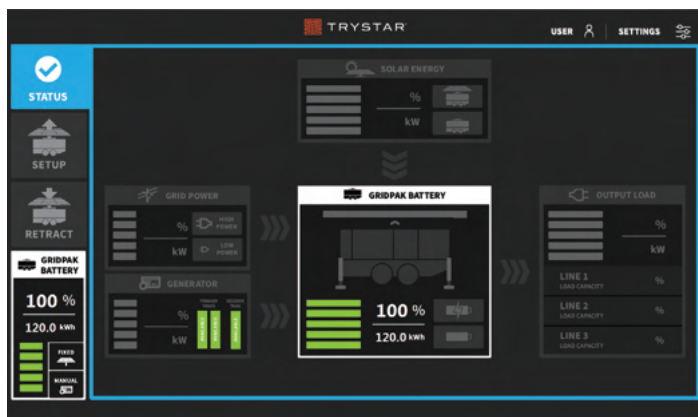

## 7.0 MANUAL PROGRAMMING

---

### 7.9 Manually Program Generator

The primary function of the GridPak's 6.5 kW LP-fueled onboard generator is to supplement solar charging during deployment. During periods of inactivity, however, the generator can be used manually to replenish the charge in the LiFePO<sub>4</sub> battery banks without fully deploying the solar array.

The functionality available through manual programming also allows the operator to use the generator to provide power directly to loads via the load receptacle panel. (See **Section 7.2.4.1**)

The manual programming function also makes it possible to control when the generator can operate. For example, if being used in a municipality (despite quiet operation), there may be ordinances governing the operation of construction and/or highway equipment. The GridPak generator can be set so that it can only operate during specific hours.

The manual generator programming function also allows the operator to choose manual charging or automatic charging. Correspondingly, if deployed, the operator can temporarily prevent the generator from operating to allow for inspection, maintenance or service.

#### WARNING

The backup LP-fueled generator on the GridPak exhausts carbon monoxide and produces heat during operation. Inhaling the exhaust can cause serious medical conditions, including death. Hot metal parts can cause severe burns. Avoid contact with the generator while it is running or hot and avoid inhaling exhaust gases.

#### WARNING

Carbon monoxide is a poisonous gas. Inhalation can cause severe personal injury or death. Substances in exhaust gases have been identified by some state and federal agencies to cause cancer or reproductive toxicity. Do not breathe in or come into contact with exhaust gases from the GridPak backup LP-fueled generator should it be operating.

## 7.0 MANUAL PROGRAMMING

### 7.9 Manually Program Generator

- From the STATUS function tab, press the SETTINGS button to enter manual programming mode
- Press the GENERATOR button to access programming

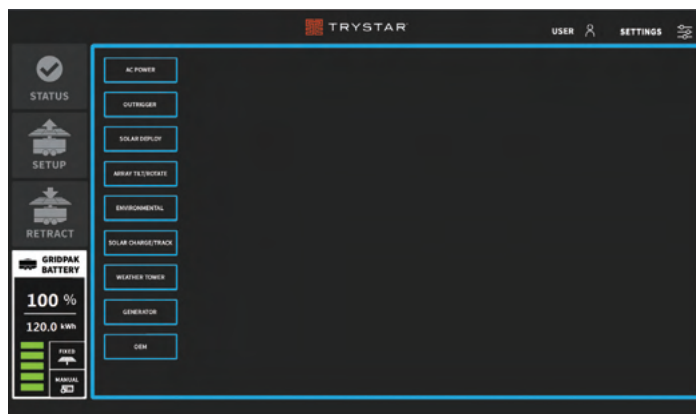
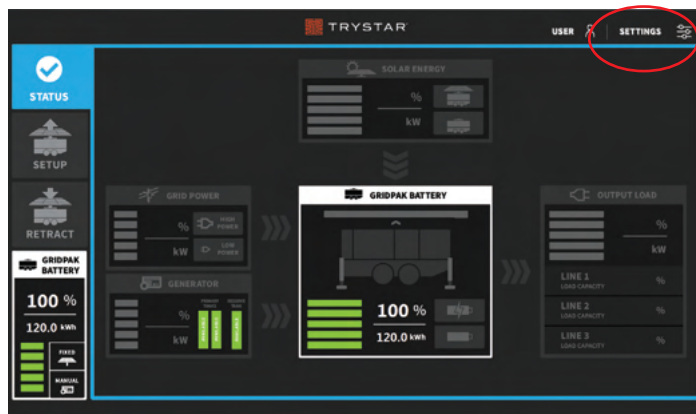

The Generator display screen provides information and programmability. The GridPak carries three 40-pound LP tanks to power the onboard auxiliary generator. Two of these tanks serve as primaries with the third tank serving as a reserve. The Propane Storage meter indicates their status in terms of volume. A tank that has fuel is green and reads AVAILABLE. When it is empty, it will be orange and read, EMPTY.

The center meter has separate Start and Stop buttons. The Status button indicates generator status – either ON or OFF.

The bottom meter of the Generator display indicates the operating temperature of the generator.

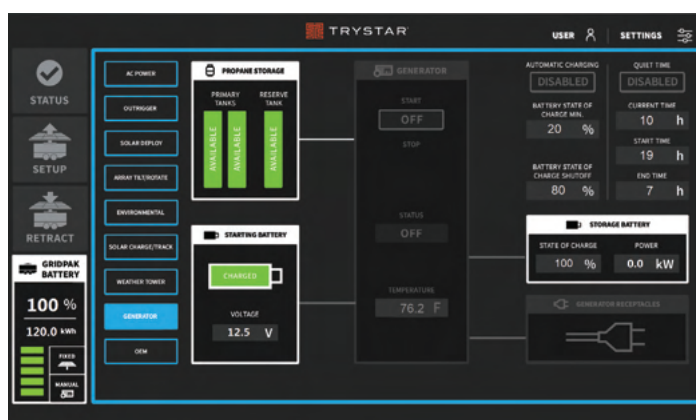

## 7.0 MANUAL PROGRAMMING

### 7.9.1 Manually Start Generator

- Press the Generator Start button to manually start the generator

The Start button is initially gray and reads OFF.

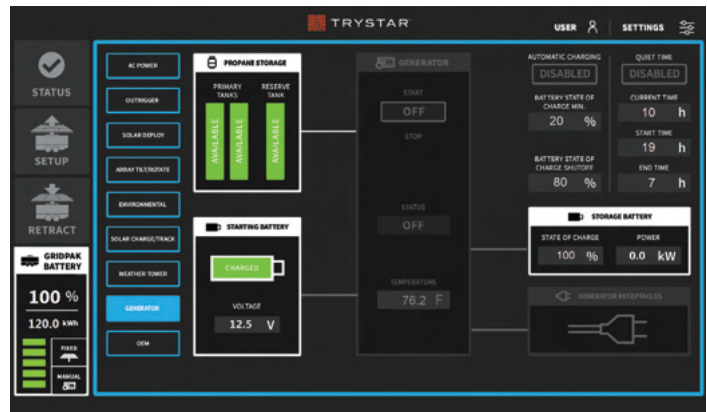

The Start button initiates the generator start sequence. The Start button will turn green and the label will read STARTING. The Status button will turn orange and the label will change to PRIMING.

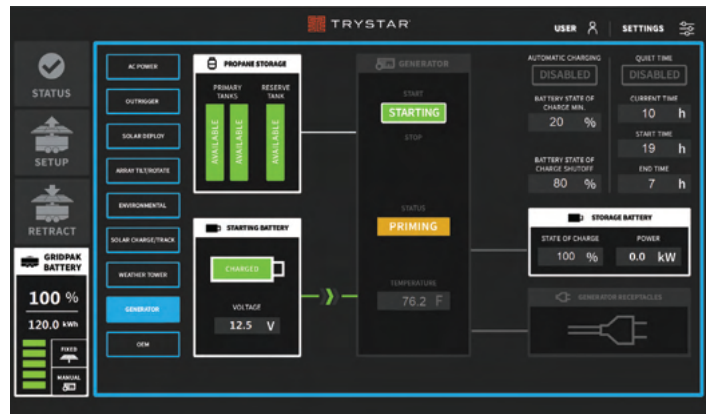

Within 3-5 seconds, the Status button will change to green and the label to ON once the generator is operating. The Start button will be hidden and the STOP button will show.

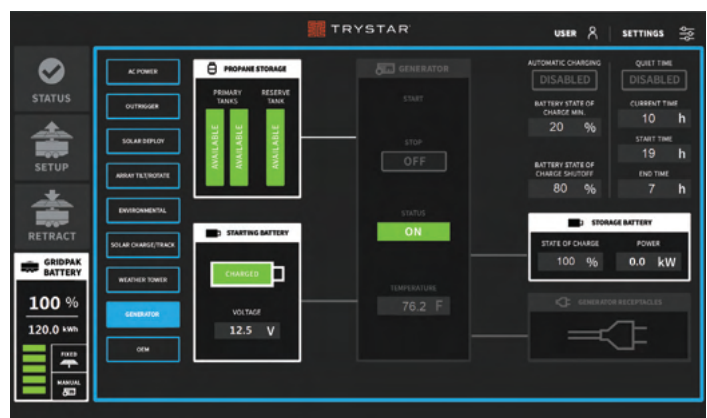

**NOTE:** During deployment, with the generator operating, there may be a need to temporarily stop it for inspection, maintenance or service. **Alternatively, changing LP tanks would necessitate either stopping the generator or preventing it from starting up.**

## 7.0 MANUAL PROGRAMMING

### 7.9.2 Manually Stop Generator

- Press the Generator Stop button to manually stop the generator  
The Stop button is initially gray and reads OFF.

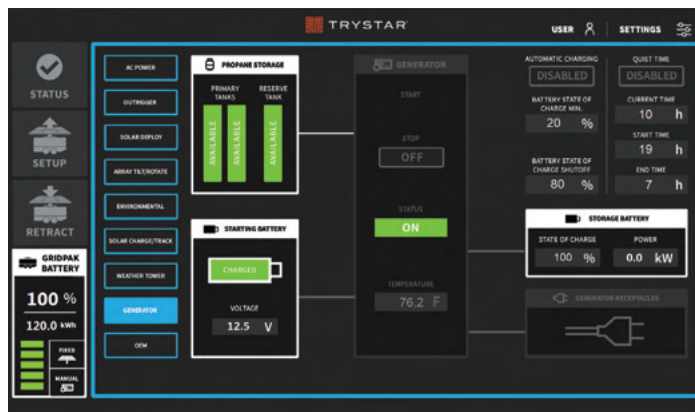

The Stop button will initially flash green and the label to STOPPING.

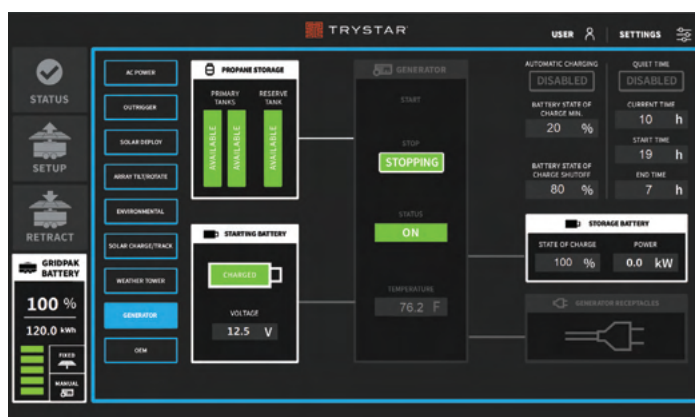

As soon as the generator stops, the STOP button is hidden and the START and Status button will turn gray and read OFF.

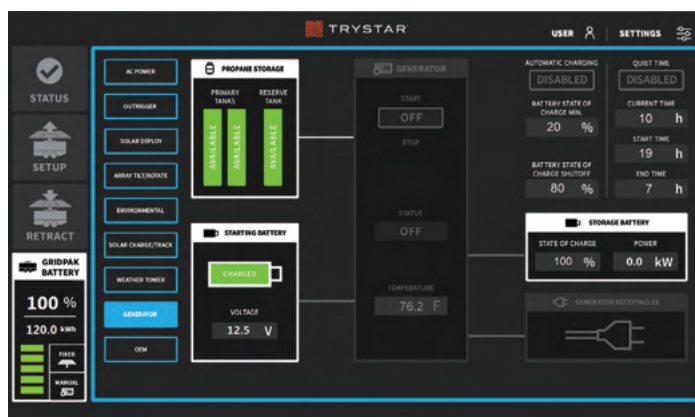

### 7.9.3 Manually Enable/Disable Automatic Charging

Automatic Charging (enabled) is not the default for the GridPak when deployed. The generator can be used to both charge the onboard LiFePO<sub>4</sub> battery banks or it can supply power externally via the power output receptacle panel.

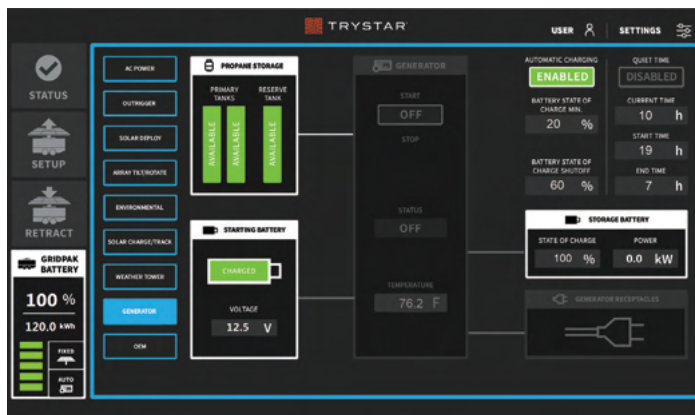

## 7.0 MANUAL PROGRAMMING

### 7.9.3 Manually Enable/Disable Automatic Charging

There are two meters below the Automatic Charging button. The top meter is Battery State of Charge Min. (Minimum). The setting shown is 20% which means when the LiFePO<sub>4</sub> battery bank charge falls below 20%, the generator will automatically turn on – unless it is disabled.

The second meter, Battery State of Charge Shut Off, is set to 60%. It means once the battery has reached a 60% charge level, the generator will shut down.

The operator can make adjustments to each setting as shown in **Section 7.9.4**.

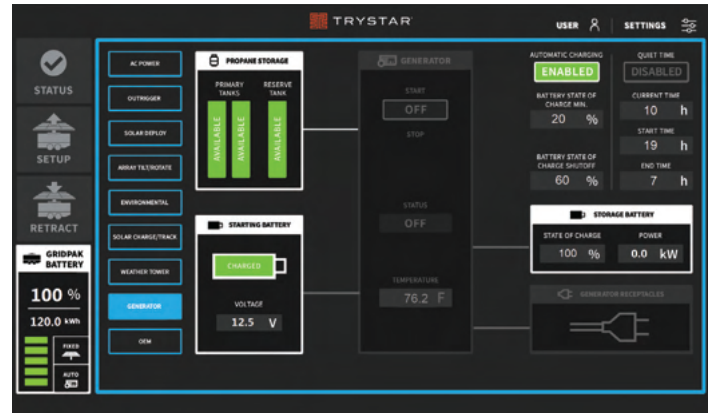

#### 7.9.3.1 Manually Disable Automatic Charging

- Press the Automatic Charging button to disable automatic charging

The Automatic Charging button will turn gray and change to DISABLED.

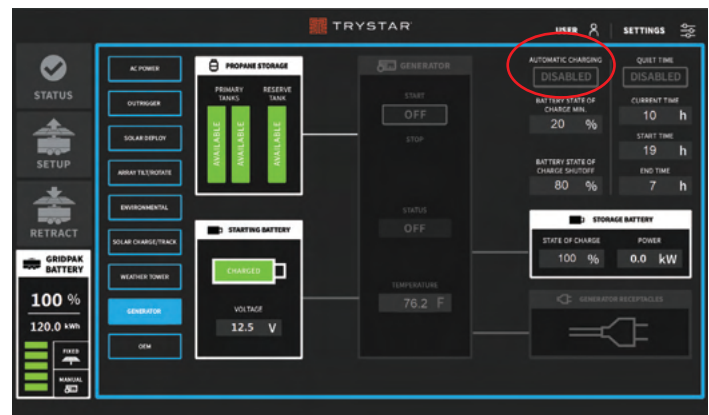

#### 7.9.3.2 Manually Enable Automatic Charging

- Press the Automatic Charging button to enable automatic charging

The Automatic Charging button will turn green and change to ENABLED.

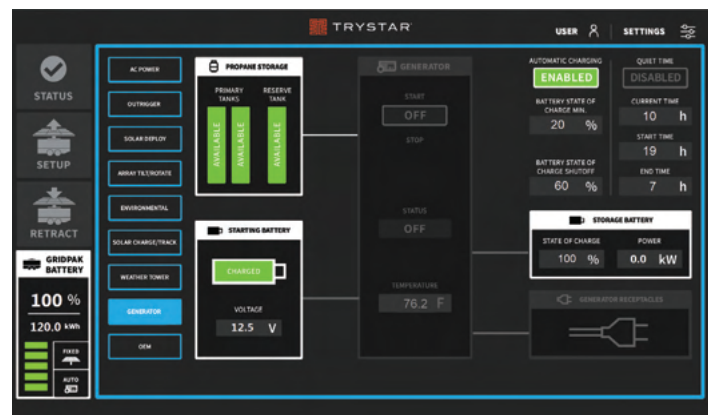

## 7.0 MANUAL PROGRAMMING

### 7.9.4 Manually Set State of Charge Minimum

There are two meters below the Automatic Charging button. The top meter is Battery State of Charge Min. (Minimum). The setting shown is 20% which means when the LiFePO<sub>4</sub> battery bank charge falls below 20%, the generator will automatically turn on – unless it is disabled.

The second meter, Battery State of Charge Shut Off, is set to 60%. It means once the battery has reached a 60% charge level, the generator will shut down.

The operator can make adjustments to each setting.

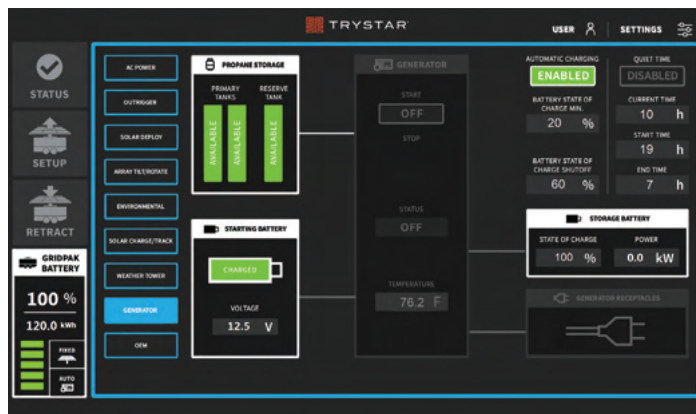

#### 7.9.4.1 Manually Set State of Charge Minimum

- Press the Battery State of Charge Min. meter

When the meter is pressed, a keyboard will appear allowing the operator to change the percent relative to how low the battery banks can fall before the generator automatically switches on. The figure in the Battery State of Charge Min. meter will also be slightly highlighted.

- Key in the new figure, and press the return arrow (←) to save it



## 7.0 MANUAL PROGRAMMING

### 7.9.4.2 Manually Set State of Charge Shutoff

- Press the Battery State of Charge Shutoff meter

When the meter is pressed, a keyboard will appear allowing the operator to change the percent relative to the charge level before the generator will automatically shut off. The figure in the Battery State of Charge Shutoff meter will also be slightly highlighted.

- Key in the new figure, and press the return arrow (←) to save it



### 7.9.5 Exiting Programming Mode

- Press the STATUS tab to exit manual programming mode

The display will return to the status home screen.

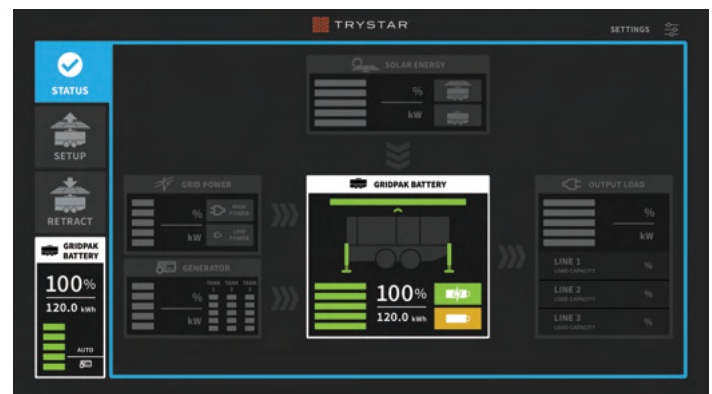

## 7.0 MANUAL PROGRAMMING

### 7.10 OEM/Service Technician Programming

The final tab in the Settings display is OEM. This tab is password-protected. Only Trystar and its approved technicians can access this sub-programming feature to perform inspections, service or maintenance.

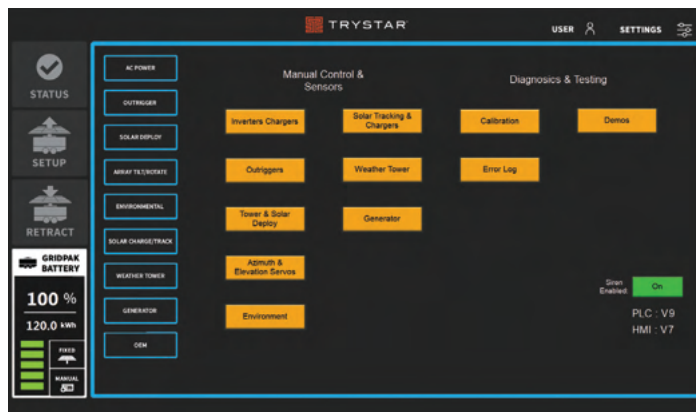

#### 7.10.1 Exiting Programming Mode

- Press the STATUS tab to exit manual programming mode

The display will return to the status home screen.

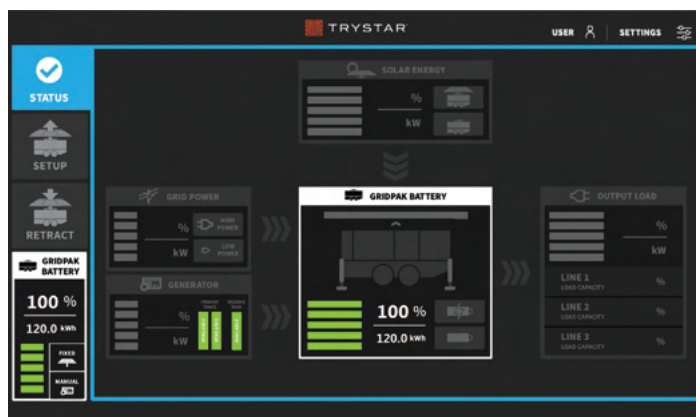

## 8.0 REPORTING SAFETY DEFECTS

---

### 8.1 Reporting Safety Defects

If you believe that your vehicle has a defect that could cause a crash or could cause injury or death, you should immediately inform the National Highway Traffic Safety Administration (NHTSA) in addition to notifying Trystar, LLC.

If NHTSA receives similar complaints, it may open an investigation, and if it finds that a safety defect exists in a group of vehicles, it may order a recall and remedy campaign. However, NHTSA cannot become involved in individual problems between you, your dealer, or Trystar, LLC.

To contact NHTSA, you may either call the Vehicle Safety Hotline toll-free at 1-888-327-4236 (TTY: 1-800-424-9153), or go to <http://www.safercar.gov>; or write to:

**Administrator**  
**NHTSA**  
**1200 New Jersey Ave SE**  
**Washington, DC 20590**

You can also obtain other information about motor vehicle safety from <http://www.safercar.gov>

**NOTES**

---

