

# Hi-Res Time Synchronization in Modern Power Systems Using PTP (IEEE 1588)

## Summary

Electrical Power Monitoring Systems need precision timing. In the past, 1-msec event recording required dedicated cabling of multiple time-sync signals, limiting applications to only the largest projects.

Precision Time Protocol (PTP) per IEEE 1588 enables highly precise time synchronization over a network, due primarily to time-stamping embedded in the 1588 Ethernet hardware. Most power industry papers have focused on the Power Profile and PTP's potential to achieve microsecond accuracy, but the associated cost and complexity are unnecessary for EPMS and SER, where 1- $\mu$ sec is not needed.

This paper proposes a "Simple PTP" Profile based on the IEEE 1588 Default Profile (2008 - Annex J, 2019 Annex I). By relaxing some requirements of the Power Profile and simplifying others, 100- $\mu$ sec accuracies over Ethernet are now possible—and affordable—just right for modern commercial/industrial EPMS.

## Introduction

Precision timing is essential for modern industrial/commercial power systems. For years Electrical Power Monitoring Systems (EPMS) have helped facility engineers manage cost, quality, safety and reliability. In the past, "Intelligent Electrical Devices" (IEDs) clocks were set over Ethernet, with accuracy no better than 1 second. In complex electrical networks, changes can occur in a quarter-cycle or less, and so 1-msec resolution is commonly accepted for meaningful analysis. Until recently, separate cabling was needed to achieve this "hi-res" time, limiting the benefits to only the largest projects. Today, Precision Time Protocol (PTP) defined in IEEE 1588 makes hires time synchronization over Ethernet simple and affordable for all.

## SER: The Black-Box Recorder for Power Systems

Like an airliner's black box recorder, Sequence of Events Recorders (SERs) record exactly what happened and when, to 1 ms. But unlike the airliner example, this data is used again and again:

- Root-cause analysis, or event reconstruction
- Advance warning of slow breakers—before they fail or increase arc-flash hazard
- Verify proper operation of automatic controls and time-current coordination
- Documentation for electric utility, insurance, warranty or legal purposes

SER systems record the exact time of the initiating event (root event), as well as the resulting series of events, all in chronological order. Some events are bad because they cannot be anticipated, and even worse if they cannot be explained. Other events are designed responses (breaker trips, control system actions, etc.). It is equally important to verify that these events happened on time—or know if they didn't.

## Evolution of Time in Power Monitoring

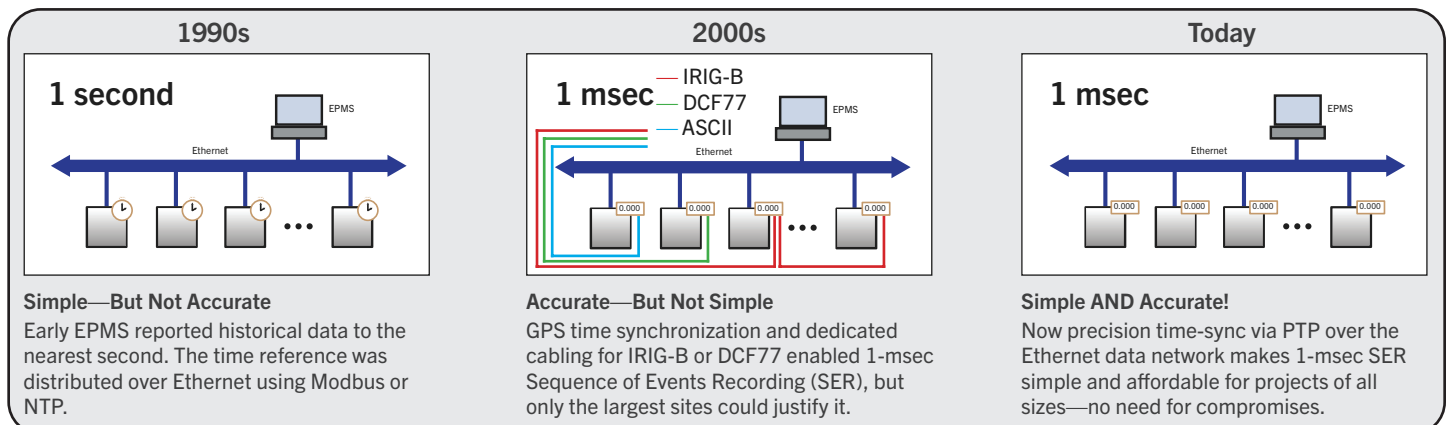

## TIME-SYNC: WHAT'S NEEDED?

### Modern EPMS: 1-msec Time-Stamping is Essential

Power system events can occur in rapid succession—within milliseconds of each other—especially in complex electrical networks with transfer schemes, backup power, UPS and other parallel paths to serve the loads. Some examples:

- Breaker open/close/trip (1/4-cycle to 5 cycles)
- Breaker reclosures (cycles, seconds)
- Utility voltage sag/surge (1 to 10 cycles)
- Faults (cycles)
- Lightning strikes (microseconds)
- Transfer operation/misoperation (cycles, seconds)
- Generator start/stop (cycles, seconds)
- UPS state changes (cycles, seconds)
- Operator actions (seconds)
- Equipment failures (transformer, generator, switchgear, UPS)

To understand what happened and when, the generally-accepted benchmark for timestamping events is one millisecond (1 ms) resolution. To achieve this, IED clocks must maintain their own accuracy at least an order of magnitude better: 100 microseconds (100  $\mu$ s). Clocks are typically synchronized to a master clock whose time is accurate, stable and traceable to a known standard (usually GPS). Since clocks drift at different rates, each IED's clock must correct its time offset to the master clock as well as tune its own frequency to that of the master, ensuring its accuracy is maintained between synchronization intervals.

## REQUIREMENTS OF IED CLOCKS

### Time Synchronization Concepts

Time synchronization in power system applications actually refers to clock synchronization, involving synchronization of clocks in terms of time and frequency. For an IED to support high-resolution time-stamping (1 ms), its clock must meet some minimum specifications:

- Meaningful resolution (1 ms timestamps, accurate to  $\pm 0.5$  ms or better)
- Provisions to synchronize to an external time reference (within 100  $\mu$ s)
- Clock frequency must be tunable, to maintain accuracy between updates

**Drift.** No two clocks measure time at the exact same rate, due to the inherent natural frequencies of their individual clock crystals, differences

---

“Man with one watch knows the time.  
Man with two watches, not so sure.”

---

in temperatures, and aging. As a result, the clocks will diverge from each other (drift) and no longer remain synchronized. A reference clock may periodically reset the other clock back to its own value, but this only brings them into synchronization for one moment in time. (This corrects for their offset only.) **Syntonization.** Tunable clocks allow for their frequency to be adjusted to match that of the reference clock, thus ensuring proper time synchronization even between intervals. This is called “syntonization.”

**Jitter and Skew.** Jitter is a short-term variation in a clock’s frequency. A clock’s skew (at a given instant in time) is the amount its frequency differs from its reference clock’s frequency. A clock operating at the same frequency as its reference clock is said to have zero skew.

**Holdover time.** Holdover time is an indication of a clock’s stability, defined as the time it can maintain its target accuracy within specifications once connection with the time reference is lost. Holdover time depends on how well the clock frequency has been tuned to the reference clock in the first place, and so this value is often expressed for a defined steady state condition. For example, after the clocks have been synchronized for a specified time (e.g., five minutes), the IED clock can be expected to remain within spec during its published holdover time (e.g., 2.5 minutes). This might not be true had the devices only been synchronized for only a few seconds.

## Hi-RES TIME-SYNC: THE PAST

### GPS Time Synchronization

GPS is commonly associated with knowing a physical location, but GPS data can provide a highly accurate time reference as well. GPS provides this “free” source of precision time for a single location—or across wide distances. A typical system includes a GPS antenna mounted on the roof or other external location allowing line-of-sight access to multiple satellites. A GPS receiver or satellite time reference decodes the antenna’s GPS time data and outputs a precise time signal using one or more protocols, as needed. Unfortunately, distributing this time reference to all IEDs can be more complicated than it may first appear.

## TIME-SYNC PROTOCOLS

### Distributing Precise Time to All Devices

Different devices support different time protocols, requiring duplicate wiring using different topologies. Each protocol has its advantages, but combining several types of devices in a single GPS time-sync system results in real-world cost and complexity. Dedicated cabling distributes the time to each device, according to the protocol it supports. The number of devices to be synchronized, the protocols required, and the distances involved all affect system architecture.

### Different Devices: Different Protocols

IRIG-B is best known, but it is typically distributed at 5V and so it presents

### Precision Time Protocols

IRIG-B—time codes typically distributed at low levels (5 Vdc) and wired point-to-point. IRIG-B has 100 pulses per second and transmits a complete date/time every second, although the year may or may not be included. The two most common variations:

- Amplitude Modulated IRIG-B (1kHz carrier)
- Unmodulated, DC Level Shift (DCLS)

DCF77—time protocol similar to IRIG-B with equivalent accuracy but distributed at 24 Vdc via multi-point wiring. DCF77 has one pulse per second (1 PPS) and transmits a complete date/time every minute.

Others—Other protocols include 1per10 (one pulse every 10 seconds) used by Sepam relays by Schneider Electric; and ASCII over RS-485, used by ION7550/7650 meters by Schneider Electric and 9510/9610 meters by Siemens.

distance and device limitations. Some multiple-device network cabling is possible, but most are limited to a small number of devices in the same enclosure, resulting in serious problems when scalability is needed. Some examples for distributing IRIG-B:

- Point-to-point or multipoint via twisted pair or coax cables
- Daisy-chain using repeaters/distribution hubs
- Hybrid systems with RS-485 subnet

Careful engineering is required to ensure that the total load imposed by all IEDs does not exceed the drive capability of the clock. Often this data is not readily available.

Complicating things further, the IRIG standard does not specify the method for distributing the signal, and so there are several types of IRIG-B commonly in use: Unmodulated IRIG-B (DCLS) and Modulated IRIG-B (AM), each of which can contain the year information or not. Terminology varies by manufacturer; some use the latest designations (e.g., B102 or B006), while others refer to a previous standard in which enabling “IEEE 1344 extensions” meant that the year information was included in the IRIG-B code. The terms “unmodulated” and “demodulated” are both used to describe the 5V DC level shift (DCLS), depending on manufacturer. However, neither term appears in the IRIG standard.

DCF77 is a similar standard protocol, originating in Germany as a radio broadcast signal, similar to WWV in the US. When used as a time-sync protocol in EPMS, DCF77 is distributed at 24V, and so it is more suitable for daisy-chaining to many devices over long distances; however, it is not supported by all applicable devices.

Other protocols are used, but each additional network introduces cost, complexity, and risks of commissioning and troubleshooting problems. Clearly, fewer networks/protocols = simpler, cheaper, better.

### The Challenges with Dedicated Cabling for Time Sync

The drawing below illustrates a typical SER system with dedicated cabling for highresolution timing using multiple time protocols. With increased distances and larger numbers of devices, repeaters and converters are required. In some cases, different protocols require different cable types. The extra field wiring between equipment lineups requires careful attention to grounding, termination and protection. Further more, if any of the equipment is outdoor gear, then optical isolation using fiber optic converters and repeaters may be needed. What begins with an expectation of a simple “extra cable for IRIG-B” (for a small system) becomes a fairly challenging, custom-engineered solution, unique to each site. Factory testing of each equipment lineup is not sufficient; the resulting system cannot be fully tested until every piece is installed and operating at the job site.

All of the factors discussed above limit scalability, increase complexity, and introduce new opportunities for errors and interoperability issues. These increase the cost of design, implementation, commissioning, support and maintenance. It is certainly understandable that some felt compelled to compromise their requirements and forfeit the benefits of SER because the cost barriers of hi-res time synchronization were simply too high. Until now.

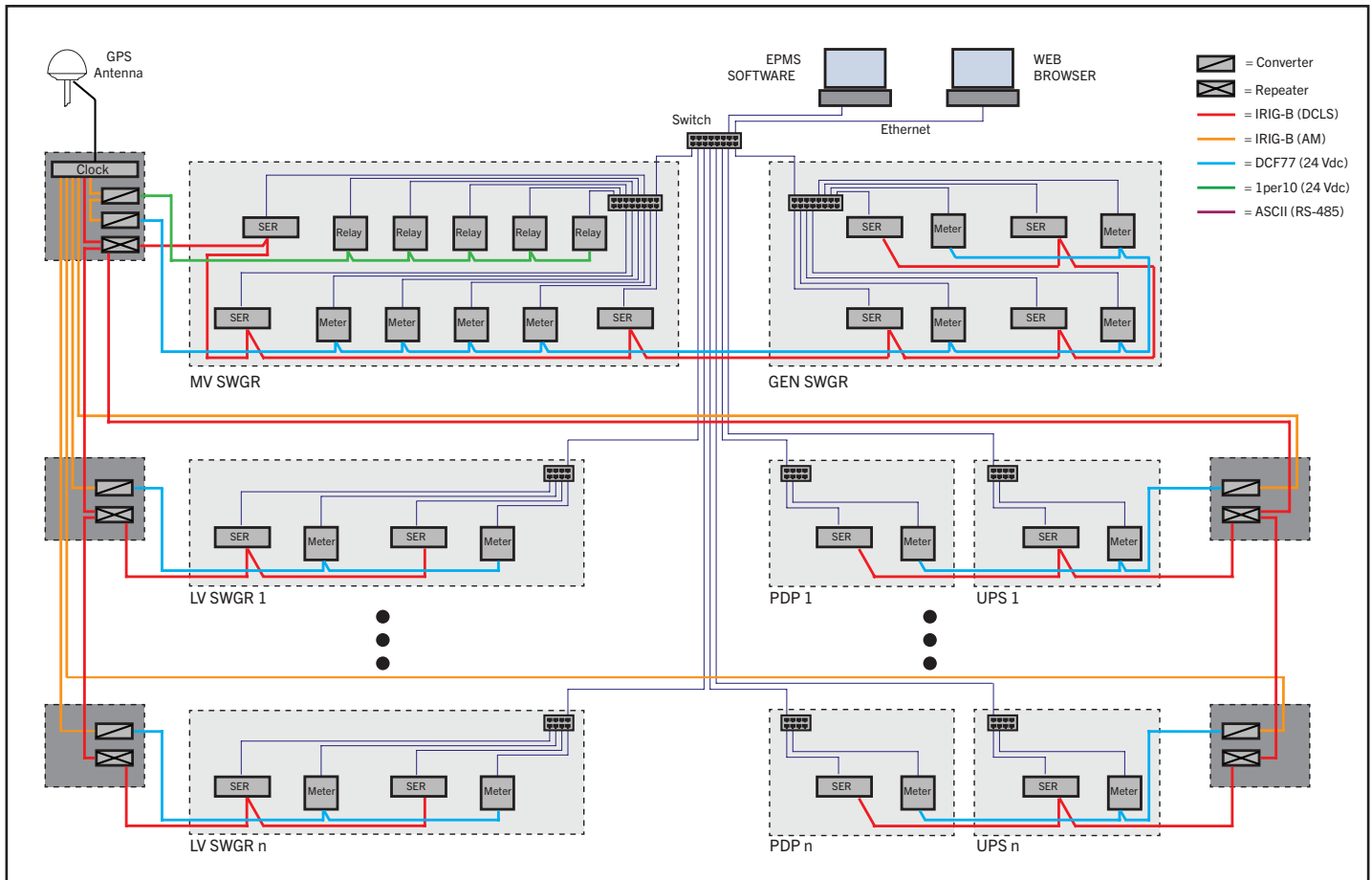

High-resolution time-sync (<1 msec): a real-world example illustrating the challenges of multiple protocols

## TIME SYNC OVER ETHERNET

Clearly, the best solution for time sync is to leverage the same Ethernet network infrastructure already used for data exchange by all the IEDs. And unlike the various redundant cabling techniques described earlier, an Ethernet-based solution has the potential to be scalable. The time-sync architecture simply follows the same topology chosen for the data network, whether that involves just a few “hops” (levels of switches) from servers to IEDs, or uses complex, redundant Ethernet topologies. Before we discuss PTP, what about NTP?

### Network Time Protocol (NTP)

NTP is the most widely applied time-sync protocol in the world. Simple Network Time Protocol source code is readily available and so it is often implemented in IEDs with few modifications. However, even with careful engineering of the server and network, the accuracy typically achieved by an NTP client is not good enough for SER. Explanations often focus on network latency, but (by far) the most significant source of uncertainty is introduced by the device’s own operating system and its software architecture.

Most of the error budget is consumed by the sending and receiving activities, not network delays. The statistical analysis used by the NTP algorithms to correct for clock offsets and end-to-end network latency are based on timestamps which themselves are subject to errors: finite resolution, conversion to floating-point values for arithmetic calculations and varying execution delays caused by the operating system. The time between when the NTP timestamp arrives and the time it is actually used is variable and non-deterministic. In addition, the NTP task can be further delayed or even preempted by higher priority tasks, depending on software design.

Complicating the overall EPMS system design further: each IED’s implementation of NTP may differ from the next. One may be accurate to 10 ms while another varies by 250 ms or more. Many IEDs rely on a single processor to perform their primary function (protection or metering), and clock synchronization is a lower priority task. Some may not even use true real-time operating systems (RTOS). Even if IEDs employ sophisticated statistical algorithms to minimize errors inherent with NTP, accuracy is affected by network traffic, processor loading, software architecture and O/S latency—the bottom line: not deterministic. For precision time synchronization over Ethernet, these limitations must be overcome. Precision Time Protocol (PTP), defined by IEEE 1588, does this.

**NTP vs. SNTP**  
There is confusion concerning accuracy expectations for devices implementing NTP vs. those which implement a client-only subset (SNTP). In general, the accuracies achievable with NTP are also possible with SNTP. The main difference is that an SNTP client supports only one NTP server at a time.

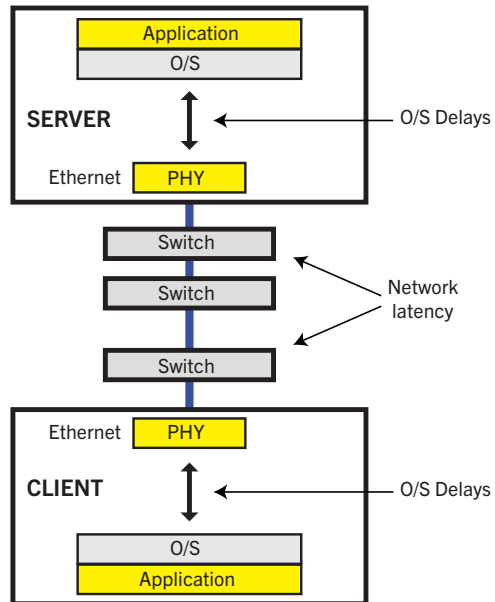

Network latency is just one source of uncertainty in timestamps. Often more significant are the variable delays introduced by each device’s operating system (O/S)

## IEEE 1588: PRECISION TIME PROTOCOL (PTP)

### IEEE Std 1588™

The IEEE 1588 standard was first published in 2002, with revisions published in 2008 and 2019. PTP is intended for a broad range of applications. With such flexibility comes an inherent lack of interoperability. The standard makes provisions for “profiles:” standard sets of options and attributes defined for specific applications. These will be described later in more detail.

### Introduction to IEEE 1588 (2019)

IEEE 1588 defines the Precision Time Protocol (PTP) with a goal of achieving very high precision for time-synchronization over a packet-based network such as Ethernet. PTP eliminates the problems previously associated with device operating system latency, by using special Ethernet hardware for precise time-stamping of the Ethernet frame send and receive times. In addition, PTP includes a very precise mechanism to correct for delays introduced in the network path from the master clock (time reference), through multiple levels of switches, to the slave clocks (time consumers). The 1588 standard also provides for redundant master clocks and an algorithm for them to select the best master (called grand-master) automatically.

The most important innovation of 1588 is the introduction of “hardware-assisted timestamping:” timestamping embedded in the PTP messages using special 1588 Ethernet hardware. This is the key difference from NTP. Hardware-assisted timestamping is achieved within the IEEE-1588 Ethernet physical interface (PHY) itself as shown below. In this way, there is no loss of accuracy between the timestamp as it is sent or received and the application layer (special 1588 code). The standard does allow a “software-only” PTP implementation, but without hardware-assisted timestamping, the achievable accuracies are equivalent to those already possible with NTP/SNTP.

The basic operation of PTP takes place in two stages: First, the devices automatically establish a hierarchical relationship, from master to slave(s). The master then broadcasts precise time data, allowing the slave(s) to adjust their clocks and fine-tune their frequencies to synchronize with the master. Every update cycle, the slave calculates corrections for offset and network latency to synchronize with high precision.

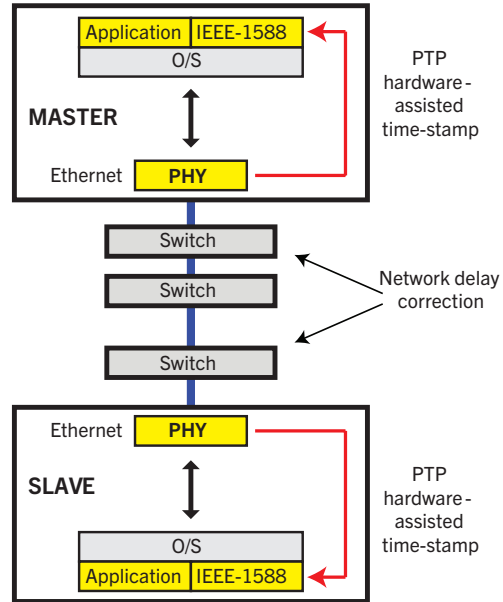

Special IEEE 1588 Ethernet hardware provides time-stamping in the Ethernet physical layer (PHY), with a direct link to 1588 code running at the application layer, eliminating device operating system delays

**PTP Clock Types**

IEEE 1588 defines several categories of clocks:

- Ordinary clock (grandmaster-capable or slave-only)
- Transparent clock
- Boundary clock

These clocks are self-organizing, in that they establish a hierarchy of interconnections based on messages exchanged. Slaves automatically sync to the master (grandmaster). A second, redundant (optional) grandmaster-capable clock can stand by in passive mode and function as grandmaster if the first is unavailable. Transparent clocks are devices with at least two 1588 Ethernet ports (e.g., PTP-aware Ethernet switches) whose function is to calculate and transmit their own contribution to any network delays. Boundary clocks also have at least two 1588 ports, but these are used to isolate the PTP network into segments: the ingress port of a boundary clock functions as a PTP slave, while one or more egress (outgoing) ports become the master (or grandmaster) for slaves in its subnetwork.

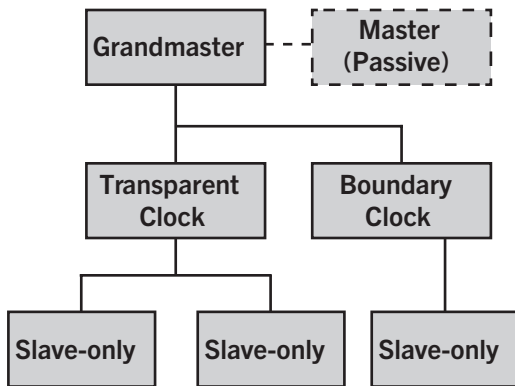

*PTP clock hierarchy*

**PTP Clock Synchronization Model**

IEEE 1588 defines several messages for distributing a precise time reference and for making corrections for network latency. All PTP messages are initiated by the master clock, except as noted:

- Announce message
- Sync message
- Follow-up message
- Delay request (initiated by slave device)

- Delay response
- Peer Delay Request and Peer Delay Response (peer to peer mechanism only)

**Announce message.** The PTP master initiates the time-synchronization process by broadcasting an “Announce message” with details about itself, such as its status, time source (e.g., GPS reference), clock class, clock accuracy, clock identity and (user-configurable) priority values. The Announce message interval can range from 1 to 64 seconds, but devices are free to make these user-configurable or just fix at one value, typically 2 seconds. These attributes are used by other grandmaster-capable clocks to compare with their own values and select the grandmaster, using the “Best Master Clock” (BMC) algorithm.

**Best Master Clock (BMC) algorithm.** The standard defines the BMC algorithm to allow each grandmaster-capable device to compare its own data set of attributes with another prospective grandmaster and then select which should serve in that role. Others wait in a passive state, always ready to assume the role of grandmaster if needed. In systems with only one grandmaster-capable device, the Announce messages are still sent, but the grandmaster always retains its role.

#### PTP Path Delay Methods

The standard defines two methods for calculating path delays:

- Delay Request-Response (or end-to-end) mechanism
- Peer Delay Request-Response (or peer-to-peer) mechanism

The Delay Request-Response mechanism calculates the delays between the master and the slave (end device). The Peer Delay mechanism is used with transparent switches (and others) to calculate delays at each node in the system. Since this is only applicable if the Ethernet network is deployed with (more expensive) 1588-compliant switches, this paper will focus instead on the first method, the Delay Request-Response mechanism.

#### Delay Request-Response Mechanism (End-to-End)

**Sync message.** The PTP master broadcasts a “Sync message” periodically (e.g., once every second) containing the approximate date and time, and other attributes. In 1-step mode, this message contains the actual, highly-precise timestamp ( $t_1$ ). In “2-step” mode, the precise timestamp ( $t_1$ ) is included in the “Follow-up” message.

**Follow-up message.** In 2-step operating mode, the master sends a Sync message, and its precise timestamp ( $t_1$ ) is recorded by the PHY and transmitted to the slaves in a second step: the Follow-up message, sent immediately after the Sync message. The slave then records the exact time in which the Sync message is received ( $t_2$ ).

**Delay Request message.** Each PTP slave periodically sends a Delay Request message to the master (at time  $t_3$ ). The Delay Request Interval is determined and advertised by the PTP master based on its ability to process the delay-request message traffic (typically 1 to 32s). The standard specifies that the Delay Request Interval must be at least equal to the Sync interval and no longer than 32 times the Sync interval.

**Delay Response message.** Finally, the PTP master responds with its Delay Response message, containing the precise time the slave message was received ( $t_4$ ).

The complete PTP Delay Request-Response mechanism is illustrated below.

**$t_1$** —The first timestamp  $t_1$  is the precise time the Sync message is sent by the master. The value of  $t_1$  is captured precisely by the master’s 1588 Ethernet hardware and is transmitted in the Follow-up message.

**$t_2$** —The precise time the Sync message is received by the slave, time-stamped by the slave’s own 1588 Ethernet hardware.

**$t_3$** —The time the slave sends its Delay Request message.

**$t_4$** —The time the Delay Request message is received by the master.

With each complete cycle of this process, the slave device uses all 4 time values to calculate adjustments to its own clock. The slave corrects for its offset with the master and tunes its clock’s frequency to closely match that of the master. In this way, the slave maintains its high accuracy in between update intervals, as well as during “holdover” periods in which the master stops broadcasting.

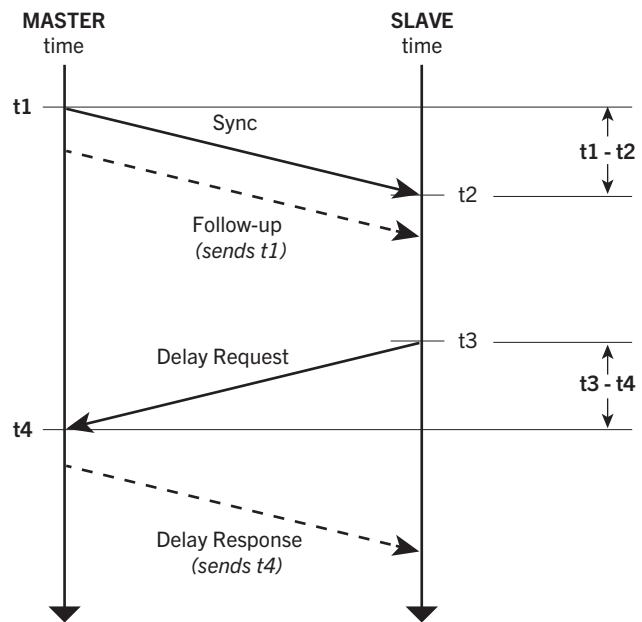

*PTP delay request-response mechanism to calculate time-sync offset and frequency*

**PTP Options**

IEEE 1588 defines several implementation options and these are further refined or prohibited according to standard profiles, such as the IEEE 1588 “Default Profile” defined in Annex J (2008) and Annex I (2019). PTP options are described below.

**Communications Model.** PTP supports both multicast (broadcast) and unicast (point to point) communications models.

**PTP vs. NTP**

One notable difference between the two protocols is the communication model. PTP uses a masterslave model, and NTP uses a client-server model.

With NTP, each client must be configured with the name or IP address of one or more NTP servers.

By contrast the PTP master broadcasts its time data, and so it is not necessary to configure PTP slave devices—the system is self-organizing.

**Relationships of Timescales**

GPS = Global Positioning System  
 TAI = International Atomic Time  
 UTC = Coordinated Universal Time

TAI is always ahead of GPS time by 19 seconds. At the time of this publication, there have been 36 leap seconds. This gives the following relationships:

TAI = GPS + 19 s  
 UTC = GPS - 18 s (and counting)  
 UTC = TAI - 37 s (and counting)

**Network Transport Protocol.** PTP supports network transport over Layer 2 (802.3), or Layer 3 (UDP/IPv4 and UDP/IPv6). UDP ports 319 and 320 are used for transmitting PTP messages, using multicast address 224.0.1.129 (end-to-end) or 224.0.0.107 (peer-to-peer).

**Path Delay Mechanism.** As discussed previously, PTP defines two different mechanisms for calculating delays introduced by the network:

- Delay Request-Response (or end-to-end) mechanism (used with standard Ethernet switches)
- Peer Delay Request-Response (or peer-to-peer) mechanism (used with 1588-compliant Ethernet switches, called Transparent Clocks)

**Operating Mode.** PTP defines two different methods for transmitting the precise time reference by the master:

- 2-Step--First a “Sync message” is transmitted with various parameters, followed immediately with a second “Follow-up message” containing the precise timestamp associated with the first message.
- 1-Step--Alternate method in which the two messages above are combined into a single “Sync message.”

**Timescale.** PTP specifies TAI as its default timescale. In fact, there are three different timescales used for time synchronization: UTC, TAI and GPS. UTC is adjusted periodically for changes in the rate of the earth’s rotation by adding or subtracting leap seconds, whereas, TAI and GPS are not affected. Most devices use UTC as their time reference but ignore any advance warning of “leap second coming” even if present, such as the announce bit in the IRIG-B standard. Furthermore, it’s not clear how they would use this information even if they did support it. There have been several instances of leap seconds in the past 20 years, the most recent in 2016. Timestamps of events recorded just before or just after the leap second may produce confusing data, but otherwise, devices are expected to operate normally without incident. The PTP standard also allows for other timescales (primarily UTC), but these are designated by alternate attribute codes. Any timescale other than TAI is called “Arbitrary” (or “ARB” ) or “application specific.”

**Profile ID.** The Profile ID is a unique descriptor of a standard subset of PTP attributes and settings used by a PTP device. The ID uses a format similar to an Ethernet MAC address. (Example: The ID for IEEE-1588 E2E Default Profile is 00-1B-19-00-01-00.)

PTP Options	Values
PTP Version Number (IEEE 1588)	v2 (2008) or v2.1 (2019)
Communications Model	Multicast or Unicast
Network Transport Protocol	802.3, UDP/IPv4, UDP/IPv6
Path Delay Mechanism	P2P or E2E Delay Measurement
Operating Mode	1-step or 2-step
Timescale	PTP (TAI) or App-specific (UTC)
PTP Profile ID	format: hh:hh:hh:hh:hh:hh

**PTP Attributes and Settings**

IEEE 1588 defines various attributes associated with a PTP clock, primarily used to report its identity, accuracy, quality and status. These are used by grandmastercapable devices to identify the best master for the system, and also by the slaves to report the fidelity of any given timestamp. A wide range of update intervals are allowed. Selected PTP attributes and settings are summarized in the table below.

**Domain Number.** PTP provides for scalability by allowing each PTP clock group to be assigned to a logical group called a domain. The domain number is an integer from 0 to 127, with a default value of 0.

**1588 Time Settings Convention:**

The IEEE 1588 standard expresses Announce, Sync and Delay message interval settings as a log base-2 of the value in seconds ( $2^{-128}$  to  $2^{127}$ ), subject to further limits established in a PTP profile.

For example, a setting of “0” =  $2^0$  (1 second). See the conversion table below for some common values.

Interval Setting (Log Base 2)	Interval Setting (Seconds)
-1	0.5
0	1
1	2
2	4
3	8
4	16
5	32

To avoid confusion, Trystar expresses all time intervals in seconds, except for Modbus register values (which require a signed-integer format). When comparing with third-party PTP settings, be careful to note the convention used.

PTP Attributes and Settings	Allowable Values
Domain Number	0 to 127 (default = 0)
Announce Interval (master)	1, 2, 4, 8, 16, 32, 64 sec
Announce Receipt Time-out (master)	2 to 10 (x announce interval)
Sync Interval (master)	0.5, 1, 2, 4, 8, 16, 32, 64 sec
Delay Request Interval (master)	0.5, 1, 2, 4, 8, 16, 32, 64 sec
Priority1 and Priority 2	128 (master), 255 (slave)
Clock Identity	(Usually based in part on MAC address)
Clock Class	06 = Normal (PTP Timescale) 07 = Holdover (PTP) 13 = Normal (App-specific Time) 14 = Holdover (App-specific Time) 52 = Out-of-spec (PTP) 58 = Out-of-spec (App-specific) 255 = Slave-only
Time Source	16 (0x10) = Atomic clock 32 (0x20) = GPS 64 (0x40) = PTP 80 (0x50) = NTP 96 (0x60) = Hand-set (manual) 144 (0x90) = Other 160 (0xA0) = Internal (none)
Clock Accuracy	32 (0x20) = 25 ns 33 (0x21) = 100 ns 39 (0x27) = 100 μs 41 (0x29) = 1 ms 43 (0x2B) = 10 ms 45 (0x2D) = 100 ms 47 (0x2F) = 1s 49 (0x31) = >10s 254 (0xFE) = unknown
Port State	1 = Initializing 2 = Faulty 3 = Disabled 4 = Listening 5 = Pre-master 6 = Master 7 = Passive 8 = Uncalibrated 9 = Slave

## PTP PROFILES

The IEEE 1588 standard is intended for a broad range of applications, ranging from A/V broadcasting, telecom, power and automation to even more exotic uses as a particle accelerator system. With such flexibility comes an inherent lack of interoperability, since each of these disciplines is free to select those aspects of the standard best suited to their needs. IEEE 1588 anticipates this situation and makes provisions for “profiles:” standard sets of options and attributes defined for specific applications.

Some IEEE 1588 standard profiles include:

- Default Profile (published as part of IEEE 1588, Annex J - 2008, Annex I - 2019)
- Audio-Video Bridging Profile (per IEEE 802.1AS-2011)
- Telecom Profile (per ITU1 G.8265.1)
- Power Profile (per IEEE C37.238-2011)
- Industrial Profile (PIP) (per IEC 62439-3)

## POWER PROFILE

### The Power Profile (IEEE Std C37.238-2011)

IEEE Std C37.238-2011 defines a comprehensive industry standard for a PTP profile, “a well-defined subset of IEEE-1588 mechanisms and settings.” Its stated purpose is to “facilitate adoption of IEEE Std 1588-2008 for power system applications requiring high precision time synchronization.” [2]

The standard is the result of work by the IEEE Power System Relaying Committee and IEEE Power System Substation Committee. The Power Profile defines several required mechanisms as well as several prohibitions:

- Accuracy goal: 1  $\mu$ s (up to 16 switches)
- All network switches must be PTP transparent clocks (1588-compliant)
- Boundary clocks are prohibited
- Layer 2 (802.3) transport protocol must be used (UDP is not allowed)
- PTP path delay mechanism: Peer-to-Peer delay mechanism only
- The PTP timescale (TAI) is required (UTC or other timescales prohibited)
- Type Length Value (TLV) tags transmit extra ID fields and network inaccuracy
- VLAN tags are required (support for virtual local area networks)
- SNMP MIB definition (required for grandmaster clocks only)

- Message update intervals of 1 second

The standard prescribes allowable errors of just 50 ns per switch, resulting in 800 ns total for the maximum number of switches, plus 200 ns for the master clock. The standard does not specify values for the slaves. The drawing below illustrates how the total accuracy target of 1  $\mu$ s is allocated across a complete system.

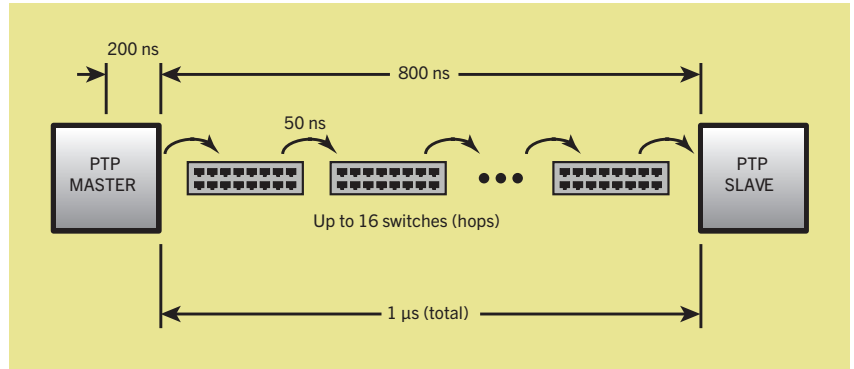

*Allocation of acceptable errors in the Power Profile*

## THE “SIMPLE PTP” PROFILE (SPTP)

The Power Profile’s stated scope of “power system applications” is unfortunate. In reality, the standard is best suited for electric utility substation automation. It targets features such as synchrophasors and waveform sampling. Its references to the “Power Industry” are best understood to mean electric utilities and others who generate, transmit and distribute power—those on the “supply side” of the electric meter. In fact, power system applications on the “demand side” of the meter follow different practices with different needs.

To achieve its 1- $\mu$ sec goal, many strict rules are defined, most notably the requirement that all Ethernet switches (up to 16 levels) must be PTP-aware, that is, equipped with special 1588 Ethernet interfaces and function as Transparent Clocks, conforming to the Power Profile. While suitable for substation automation, this requirement effectively disqualifies the Power Profile from use in other power system applications where 1- $\mu$ sec accuracy is not required.

### The Goldilocks Profile—Just Right

The IEEE 1588 standard alone is too general, and the Power Profile is too strict. A “Simple PTP Profile” is needed that is “just right” for commercial/ industrial power system applications (including data centers, hospitals and microgrids). Starting with an accuracy goal of 100  $\mu$ sec (not 1  $\mu$ sec), many simplifications are possible. The most significant is to take advantage of the same Ethernet network infrastructure used for power monitoring, without requiring special PTP-aware Ethernet switches (transparent clocks). Eliminating this requirement greatly reduces cost and simplifies the system hierarchy to a single grandmaster and slave-only clocks. There is no need for special prioritization of PTP packets in managed switches, nor any constraints on network topology. The Simple PTP Profile uses the

simpler, delay request-response mechanism for clock synchronization. Other simplifications include support for UTC timescale instead of TAI, and longer message intervals (e.g., 32 sec, not 1 sec) to reduce network traffic.

The proposed “Simple PTP” Profile (dubbed “SPTP”) for commercial/ industrial power system applications is actually based on the IEEE 1588 “Default Profile” defined in its Annex J - (2008). Devices using SPTP are interoperable with others set to use this profile.

Comparison Table: PTP Profiles

IEEE 1588 (All Profiles)	“Simple PTP Profile”	Power Profile (C37.238)
<b>GENERAL</b>	<b>SIMPLE</b>	<b>STRICT</b>
Target accuracy: nanoseconds	<b>Target accuracy: 100 μsec</b>	Target accuracy: 1 μsec
All clock types	Master and Slave-only	All clock types except boundary
Unicast or Multicast	Multicast	Multicast
802.3 (layer 2), UDP/IPv4, UDP/IPv6	UDP/IPv4	802.3 only (layer 2)
PTP-compliant switches	<b>No special switches required</b>	PTP-compliant switches required
End-to-end or Peer-to-peer	End-to-end (E2E) only	Peer-to-peer (P2P) only
1-step or 2-step	2-step	1-step or 2-step
Variable delay requests	32 seconds	Variable delay requests (typically 1 second)
TLV, MIB, VLAN tags optional	None	TLV, MIB, VLAN tags req’d.
Does not address max no. of slaves	<b>Designed to support 200+ PTP slaves</b>	Does not address max no. of slaves (< 40?)

## PRACTICAL IMPLEMENTATION OF PTP TODAY

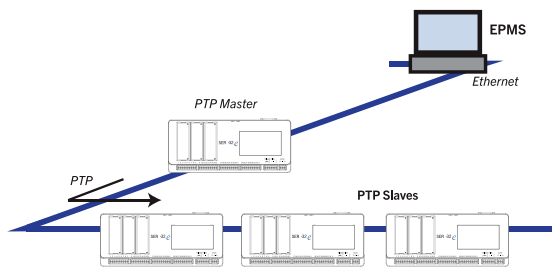

### System Building Blocks

The Trystar Sequence of Event Recorders (model: SER-32e, SER-3200 and 2408-PTP) support PTP according to IEEE1588 - 2008 and 2019.

User setup determines whether the device functions as a PTP master or PTP slave (or neither, and is simply installed for future use).

In addition to PTP, the Trystar SERs offer several time-sync input and output options, as well as trigger output for waveform capture by a meter or relay. Various building blocks are described below, with emphasis on SER time-sync inputs and outputs for interoperability with other devices. And unlike some legacy time-sync systems described previously, these building blocks form systems that are scalable to the largest installations.

## SYSTEM ARCHITECTURE

### SERs: PTP Master and Slaves

In the application shown below, the first SER serves as PTP master (grandmaster). All other SERs sync automatically using PTP over the Ethernet network. Unlike NTP, which requires each client to be configured with the IP address of at least one NTP server (and possibly update interval), no configuration is needed for the PTP slaves.

The SER serving as grandmaster may use any convenient time source: IRIG-B, DCF77, NTP or Modbus TCP. If the requirement is simply to ensure that all devices are synchronized with each other (and not necessarily to GPS time), the first SER may even accept periodic updates from an EPMS server using Modbus TCP. GPS antenna or receiver is optional. However, most systems benefit from having all clocks synchronized with high accuracy to a reference time source traceable to a known standard, such as GPS. Specific system examples follow.

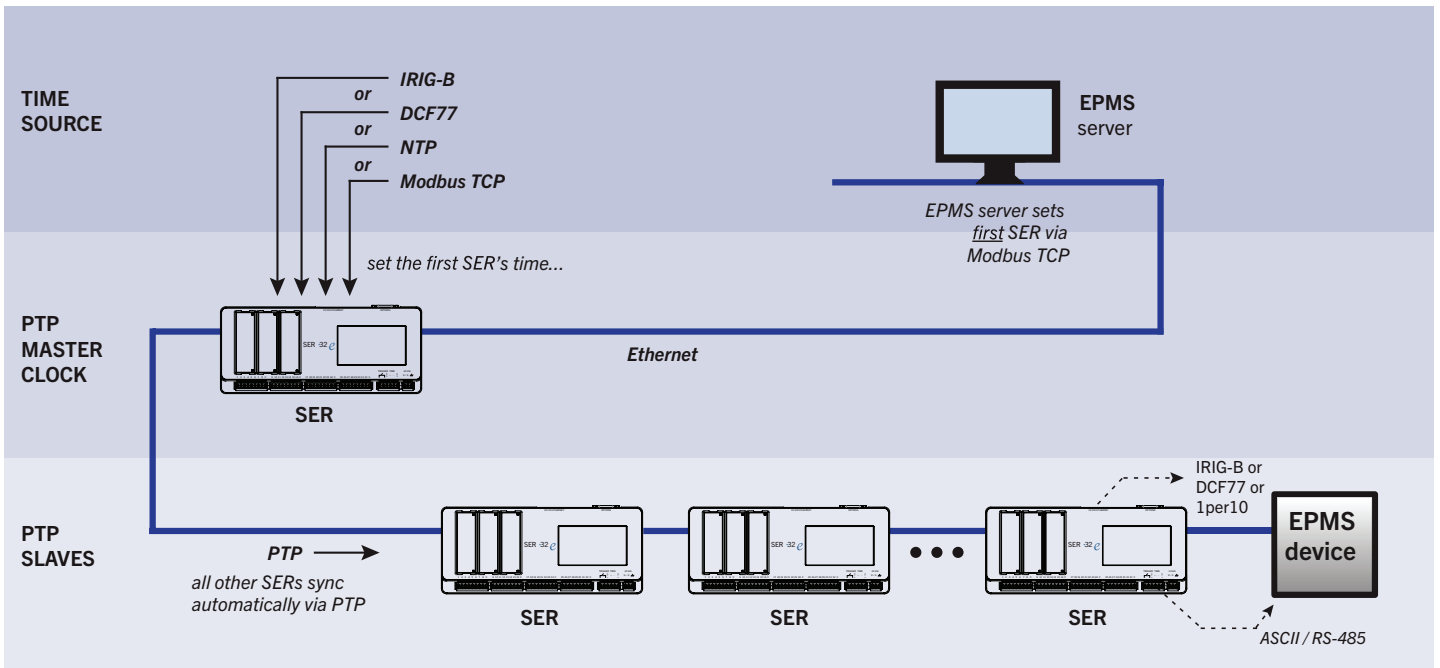

Set the first SER, all others sync automatically using PTP

## PTP SYSTEM: SER MASTER AND SLAVES (DCF77 INPUT TO FIRST SER)

In the example shown below, the first SER accepts DCF77 as its time source (from an STR-100 connected to a GPS antenna) and serves as PTP master (grandmaster). All other SERs sync automatically using PTP over the Ethernet network.

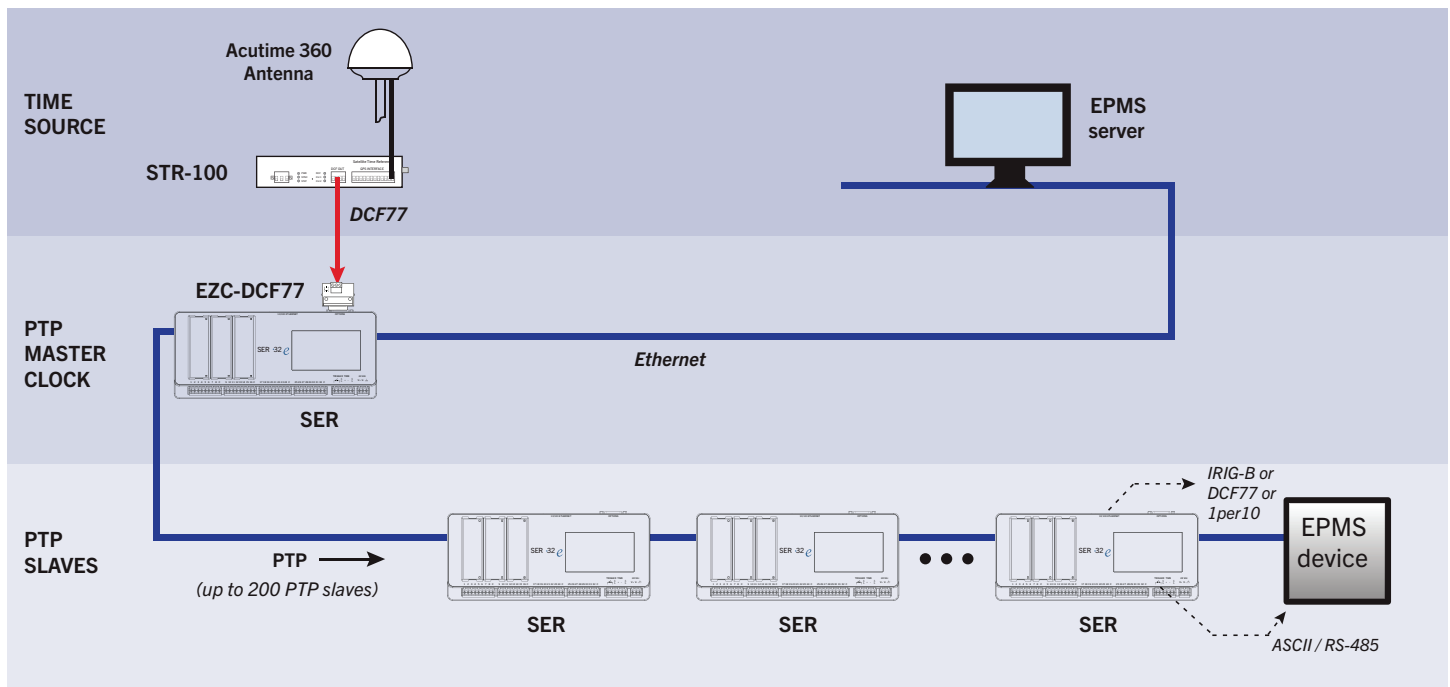

*PTP time sync system: the first SER accepts DCF77 time sync (from STR-100), serves as PTP master for all other SERs*

## PTP SYSTEM: SER MASTER AND SLAVES (IRIG-B INPUT TO FIRST SER)

In the example shown below, the first SER accepts IRIG-B as its time source (from a third-party clock) and serves as PTP master (grandmaster) for all other SERs. The clock also provides NTP time-sync for the EPMS server.

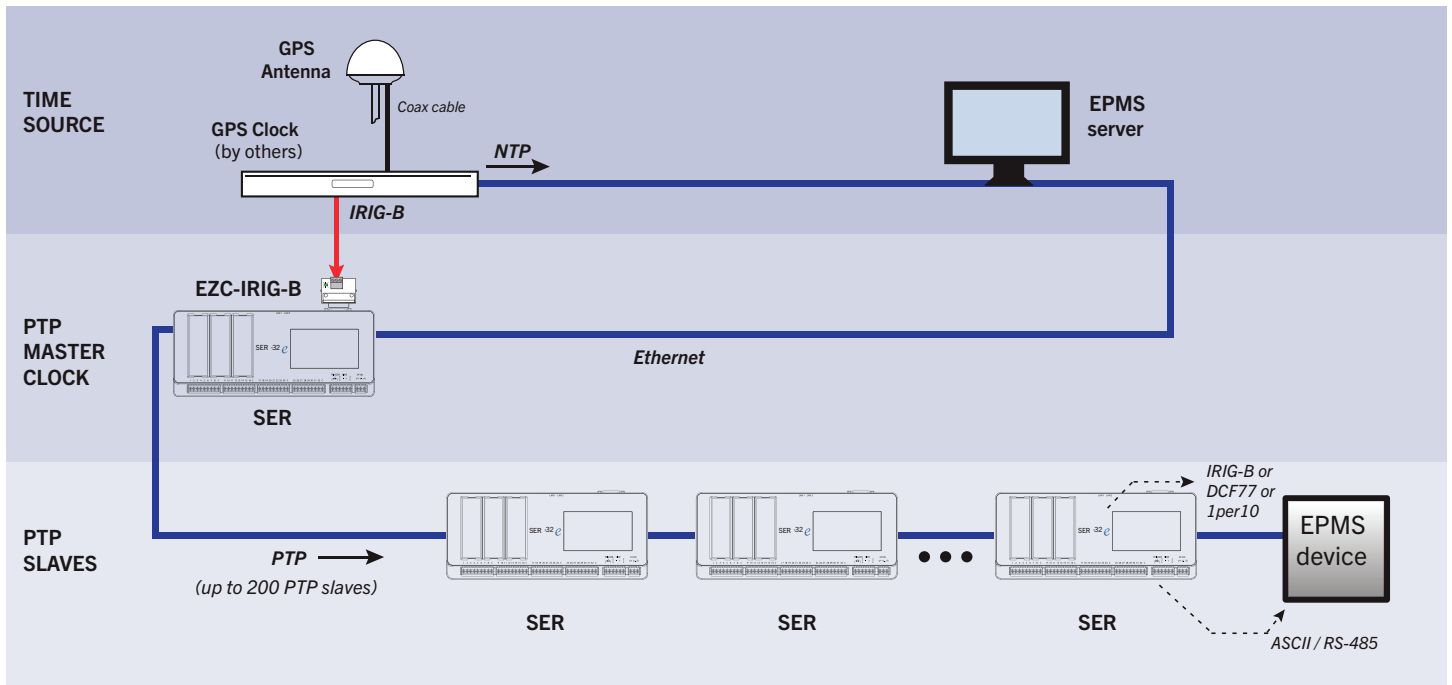

PTP time sync system: the first SER accepts IRIG-B time sync (from 3rd-party clock), serves as PTP master for all other SERs

## PTP SYSTEM: SER MASTER AND SLAVES (IRIG-B INPUT TO MASTER PLUS STANDBY)

As stated previously, PTP clocks are self-organizing, in that they establish a hierarchy of interconnections based on messages exchanged. Slaves automatically sync to the master (grandmaster). A second, redundant (optional) grandmaster-capable clock can stand by in passive mode and function as grandmaster if the first is unavailable. In the example below, the first two SERs accept IRIG-B as time source (from a thirdparty clock); the first SER serves as PTP master (grandmaster) and the second SER remains in passive (standby) mode.

In addition to providing a backup to the primary PTP master to increase system reliability, this architecture also provides a built-in path for scalability in case it is needed in future expansions. The next section continues this discussion.

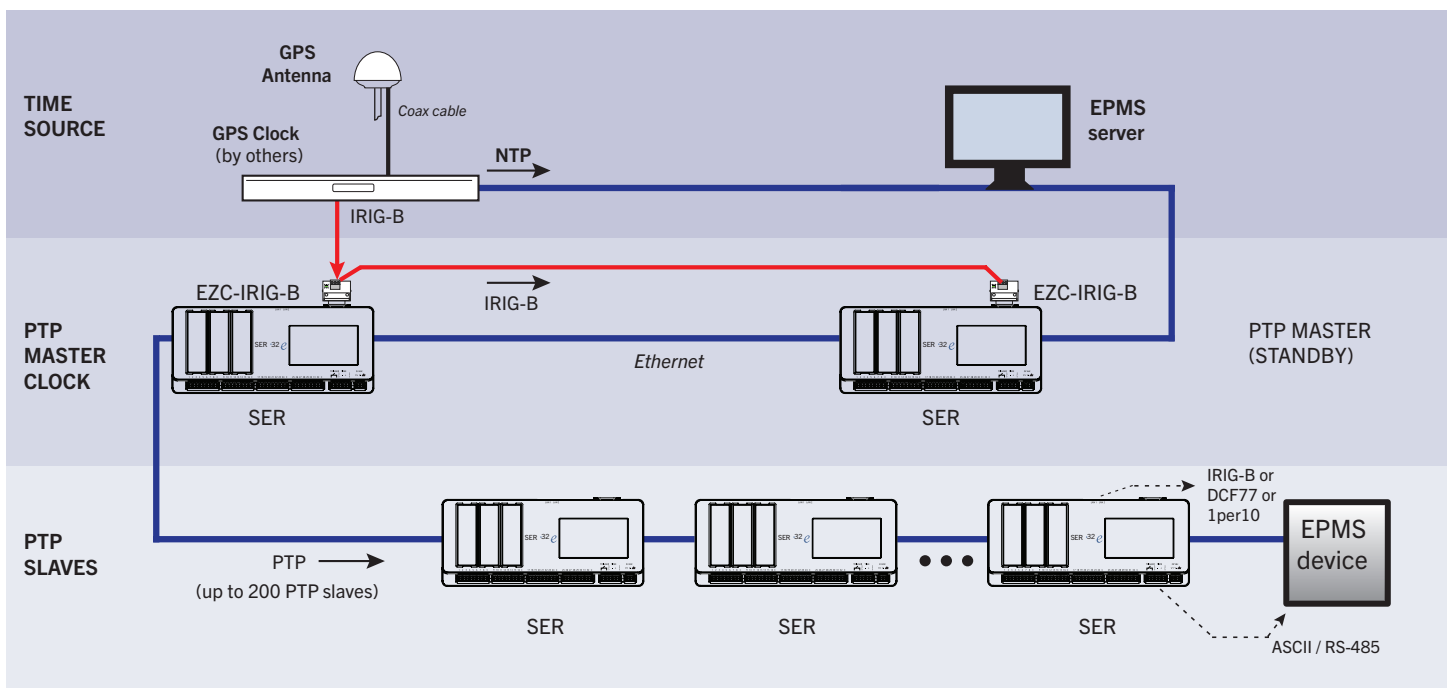

*PTP time sync system: the first SER accepts IRIG-B time sync (from 3rd-party clock), serves as PTP master for all other SERs*

# SCALABILITY

## PTP Scalability

Trystar Event Recorders have been tested under real-world network conditions and are proven to maintain hi-resolution time in large systems with over two hundred devices. Much larger systems are expected to function satisfactorily, but if extreme network conditions prove otherwise, there is a simple solution. Instead of bringing IRIG-B or DCF77 to just one SER serving as a single grandmaster, the same time signal can be connected to a second SER to serve as a second grandmaster, using a different domain number. Half of the slave devices would simply be set to this second domain number, resulting in two logical PTP systems, independent of each other. In this way, PTP is scalable for virtually any size project, and greatly simplifies building out a system in phases.

Note that the drawing below which illustrates scaling up a PTP time-sync system is nearly identical to the previous example with a redundant SER as backup PTP grandmaster. The physical connections are the same; the system is simply reconfigured to use multiple PTP domains (settings change only).

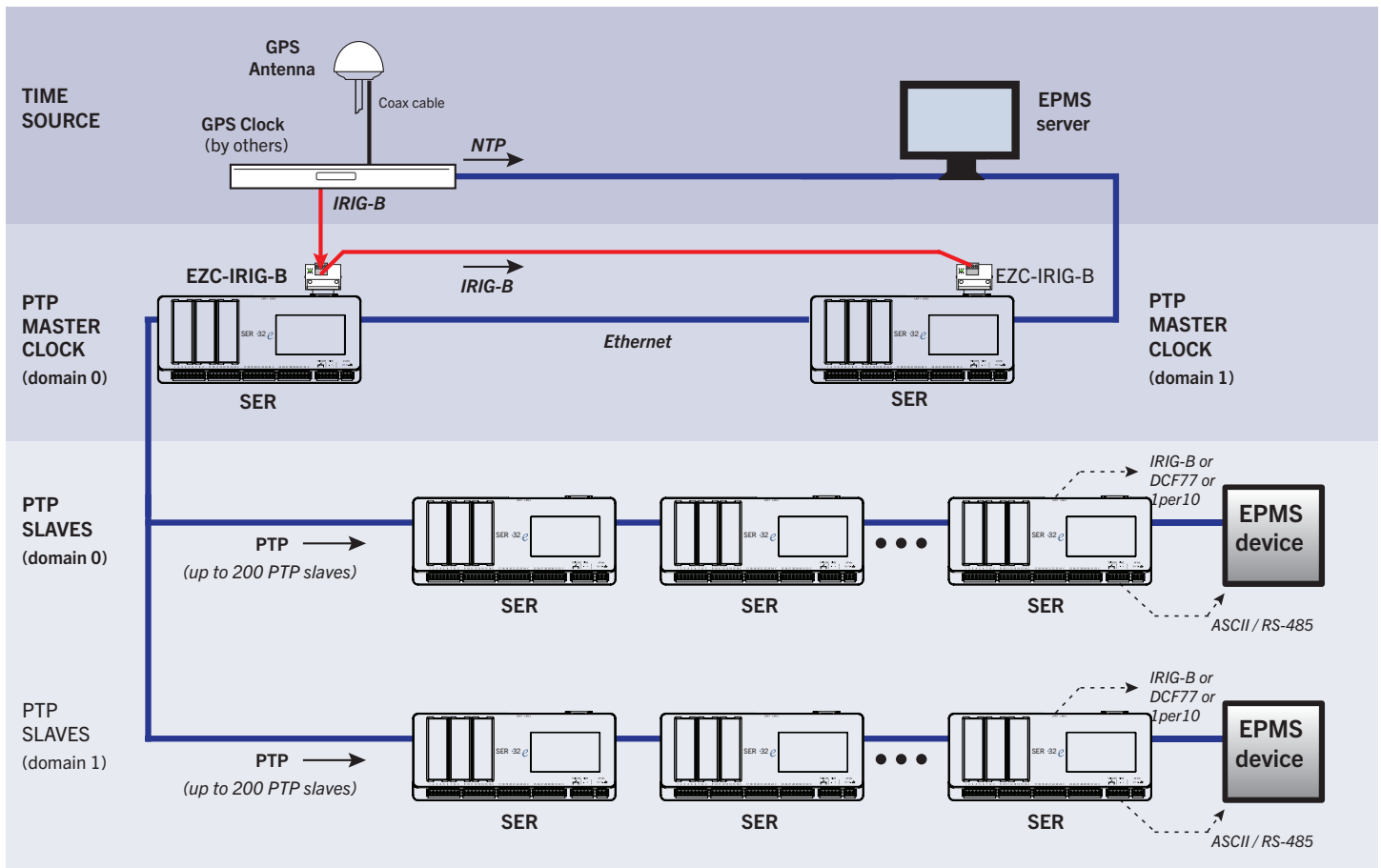

PTP time sync system: two SERs accept IRIG-B time sync (from third-party clock), one serves as PTP master for SERs on PTP domain 0; the second serves as PTP master for SERs on PTP domain 1; this allows the system to scale up easily as additional devices (PTP slaves) are added

## PTP SYSTEM: THIRD-PARTY GPS CLOCK AS PTP MASTER AND SERs AS PTP SLAVES

### Third-party Clocks as PTP Grandmaster

For small systems (up to 10 PTP slaves), it may be possible to use a third-party GPS clock as PTP master instead of a Trystar SER. The GPS clock must be configured to use PTP options and settings compatible with the Simple PTP Profile used by the SERs. Normally, selecting the 1588 Default Profile is sufficient. In addition, it may be necessary to increase the grandmaster's Delay Request Interval. Consult the GPS clock manufacturer for specifications on the maximum number of PTP slaves it can support, as well as recommended adjustments to any other settings. In general, Trystar recommends using SERs as both PTP master and slave.

### Warning about Some Third-party PTP Masters

Trystar has tested its Trystar SERs (PTP slaves) with several third-party clocks as PTP masters with good results. However, some third-party clocks did not perform well when scaled up to systems with a large number of PTP slaves. Unfortunately, the current IEEE 1588 standard does not specify the number of PTP slaves that a given PTP grandmaster must support. For this reason, Trystar recommends against using third-party PTP masters unless specific testing has been done.

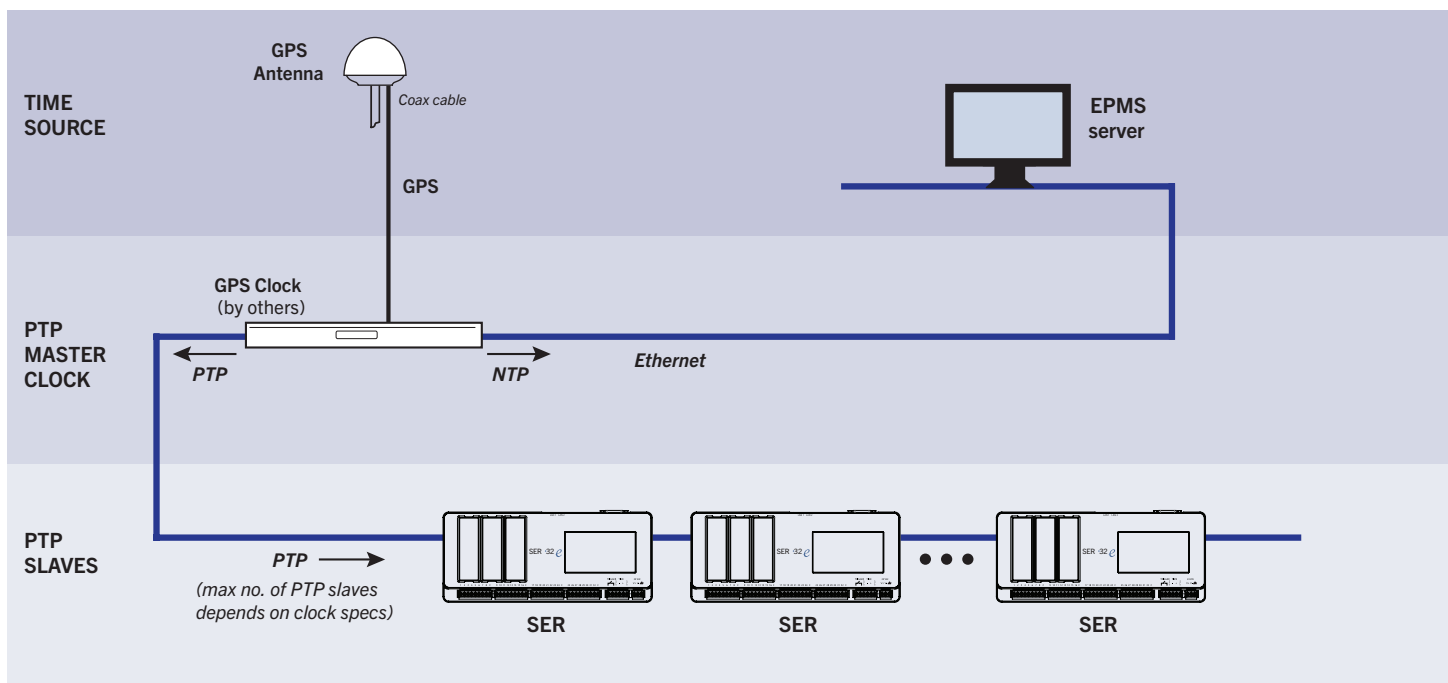

*A third-party GPS receiver/clock serves as PTP master for all SERs (and other EPMS devices that support PTP)*

## PRACTICAL IMPLEMENTATION OF PTP TODAY (CONT.)

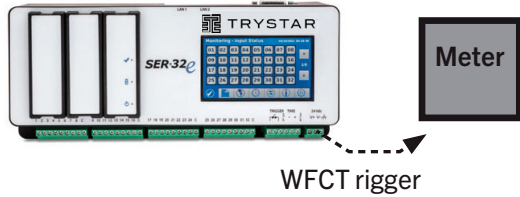

SER, with Trigger Output for Waveform Capture

### Trigger Output for Waveform Capture by Meter

In addition to precise time synchronization via PTP, a second form of synchronization provides critical data for power system analysis. The SER can be configured to output a trigger pulse for any detected status change. Typically, this is used with a compatible power meter to capture voltage and current waveforms associated with the event, both pre- and post-event.

Whether the power meters themselves have the benefit of high-res time sync or not, it is easy to correlate the waveforms with the precise time-stamp by the SER device, making the SER’s I/O a logical extension of the power meter’s own capabilities.

### No PTP? No Problem

Need to sync meters or relays that don’t support PTP? No problem. Trystar Event Recorders offer ways to integrate these devices by converting the PTP time reference to the legacy protocol(s) required, effectively making them “PTP-enabled.” Even though some additional factory wiring is needed, the cost and complexity of field wiring between lineups is eliminated through the use of PTP.

The supported legacy protocols are:

- IRIG-B (Unmodulated)
- DCF77
- 1per10
- ASCII serial time code (over RS-485)

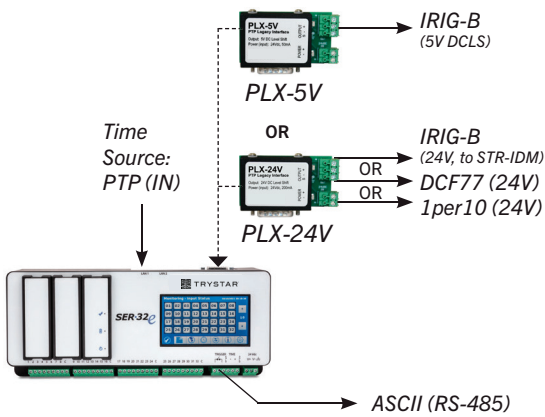

Trystar SER as PTP Slave, with PTP Legacy Interface and ASCII (RS-485) Time-sync Outputs SER-32e

### Time-sync Output: IRIG-B (Unmodulated)

The SER can be configured to output the most common form of IRIG-B: Unmodulated, or DC Level Shift (DCLS) at 5 Vdc nominal, via a PTP Legacy Interface (PLX-5V) connected to its top DB-15 port. This IRIG-B time code includes the full date/time, including the year (IRIG code “B007”), and is compatible with most meters and relays that support IRIG-B. For reliable distribution over longer distances or to a number of devices, this same IRIG-B code can be output at 24 Vdc using a PLX-24V, wired to one or more Trystar STR-IDM IRIG-B Distribution Modules for step-down to 8 conventional IRIG-B signals (at 5 Vdc) per STR-IDM. See STR-IDM instruction bulletin or Tech Note TN-101 on SER System Architectures for more details.

### Time-sync Output: DCF77

The SER can be configured to output the standard DCF77 signal (24 Vdc) via the PTP Legacy Interface (PLX-24V). This protocol is most commonly used by PowerLogic CM3000/4000 series meters from Schneider Electric and Power Xpert PXM 4000/6000/8000 meters from Eaton.

**Note:** Only one protocol can be selected for output via the PLX connector (IRIG-B, DCF77 or 1per10). However, for maximum flexibility, the ASCII / RS-485 output is enabled by default any time an SER is configured with time source = PTP. Thus, an SER can output one of these protocols (via the PLX connector) and output the ASCII / RS-485 signal as well.

#### Time-sync Output: 1per10

The PTP Legacy Interface PLX-24V is also used to output one pulse every 10 seconds (at 24 Vdc). This signal is most commonly used by Sepam 20/40/80 protective relays from Schneider Electric.

#### Time-sync Output (ASCII / RS-485)

The SER has a built-in RS-485 communications port that can be used to output the ASCII serial code (Time + Quality) required by some power meters, such as ION 7550/7650 from Schneider Electric and 9510/9610 from Siemens. The SER is configured to accept PTP as its time source and enabled as time-sync master generating ASCII RS-485 output to one or more devices. If desired, up to 16 devices can be synchronized from one SER over RS-485.

## EPMS SYSTEM EXAMPLE (Sync first SER via NTP)

The first EPMS system architecture example is illustrated below.

**Time Source.** The NTP server and first SER clock may differ by 10-100 msec; however, all other devices are synchronized more precisely with each other.

**Time Distribution.** The first SER serves as PTP grandmaster for all other Trystar SERs (PTP slaves), synchronized within 100  $\mu$ sec of each other.

**Time Conversion.** If other EPMS devices do not yet support PTP, then a nearby SER can also be used as a “time-sync hub” to output the legacy protocol needed. For illustration purposes, protective relays and meters are shown which require different time protocols, along with a nearby SER which outputs the protocol needed:

- MV (medium voltage) switchgear: relays use IRIG-B and meters use ASCII/RS-485
- Generator switchgear: relays use IRIG-B and meters use ASCII/RS-485
- LV (low voltage) switchgear or switchboards: meters shown use IRIG-B
- PDP (power distribution panel): meters shown use DCF77
- UPS cabinets: meters shown use ASCII/RS-485

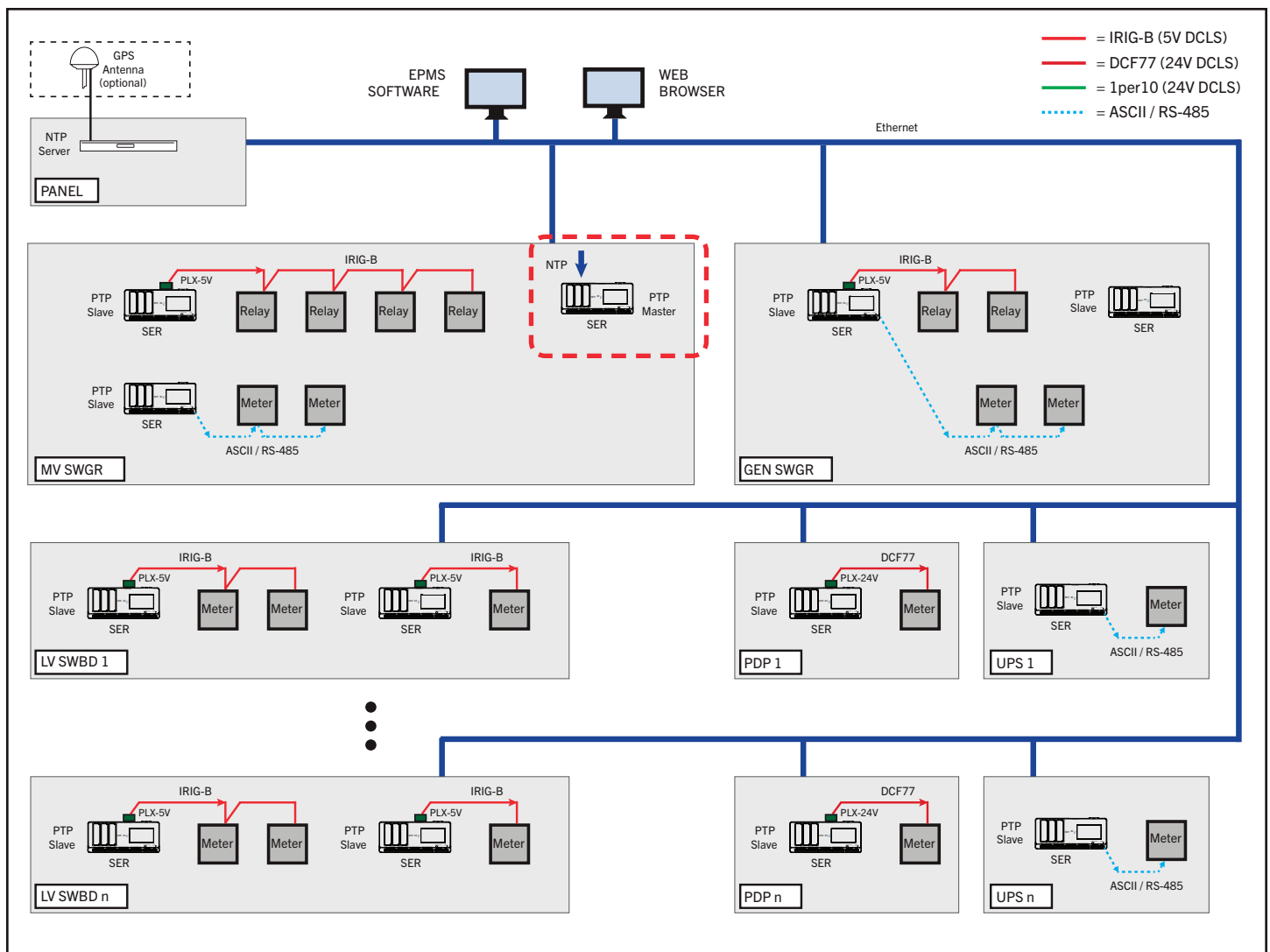

EPMS SYSTEM EXAMPLE—High-def time-sync over Ethernet using PTP, first SER syncs to a network time server (NTP), GPS optional

## EPMS SYSTEM EXAMPLE (IRIG-B, first SER in same panel)

**Time Source.** The first Trystar SER (located in the same panel as the GPS clock) gets its time source from the clock via IRIG-B, not NTP. This improves the relative accuracy to the UTC time reference, as compared with using NTP as its time source.

**Time Distribution and Conversion.** The remainder of the example is unchanged from the previous example. The protective relays are assumed to support IRIG-B, and so a PTP slave SER device outputs this signal to the relays. Likewise, all the other relays and meters are shown using the time-sync protocols they support.

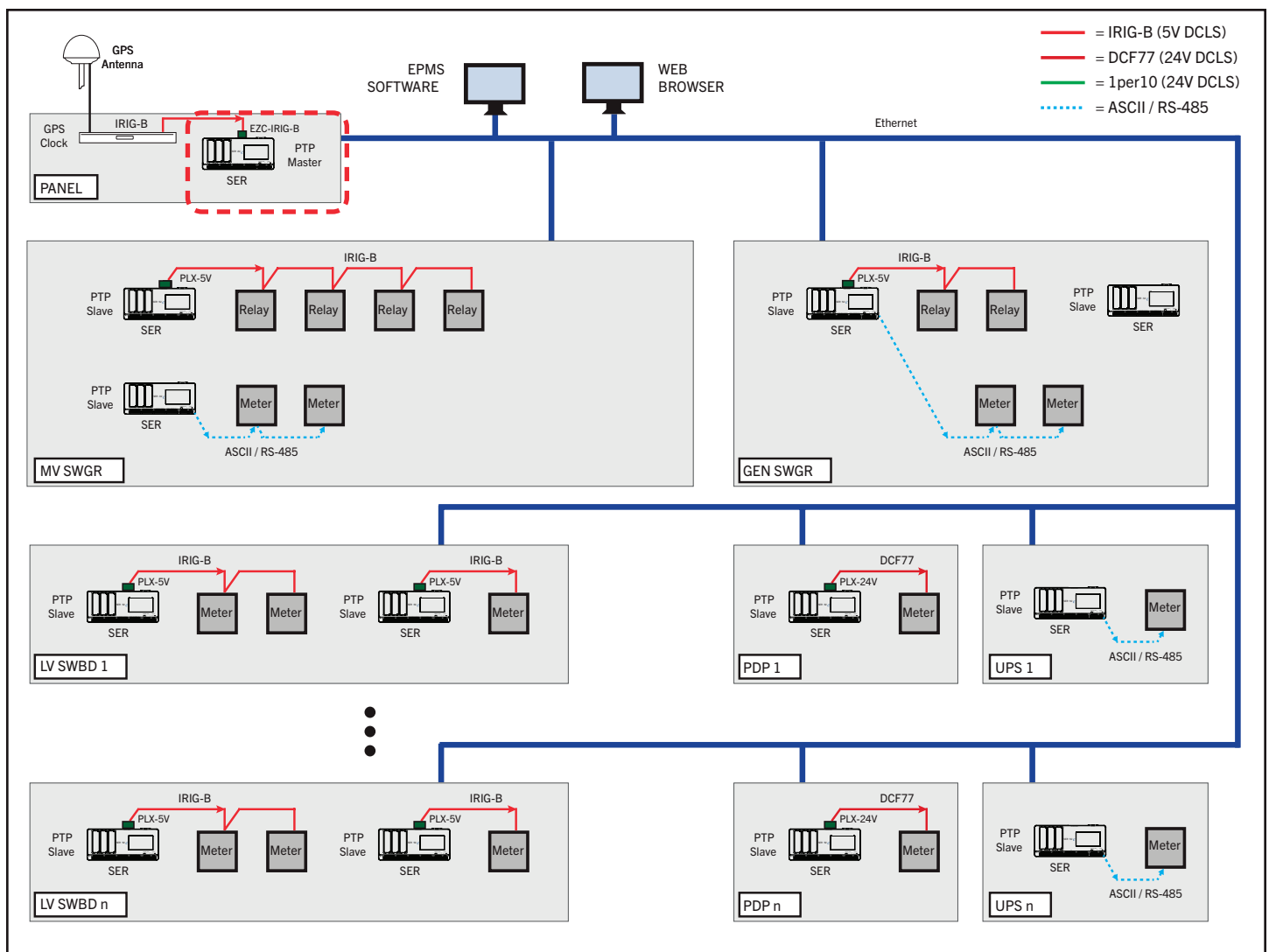

EPMS SYSTEM EXAMPLE—High-def time-sync over Ethernet using PTP; first SER is in same panel as GPS clock (IRIG-B time source)

## EPMS SYSTEM EXAMPLE (Sync first SER via IRIG-B, GPS clock)

The next example is a variation on the design in the previous example.

**Time Source.** The first Trystar SER is located in the MV switchgear and accepts IRIG-B as its time source from a GPS clock.

**Time Distribution (IRIG-B).** Most protective relays also support IRIG-B time sync, and so the same IRIG-B signal is daisy-chained to sync the relays, as well. If the number of relays exceeds the number of devices the clock can support with one IRIG-B channel, then a second IRIG-B output may be needed.

**Time Distribution (PTP).** The first SER serves as PTP grandmaster for all other Trystar SERs (PTP slaves), synchronized within 100  $\mu$ sec of each other.

**Time Distribution (NTP).** The GPS clock may also be equipped with an NTP server option to sync devices which can accept NTP but do not support a precision time protocol, such as the EPMS server.

**Time Conversion.** As in previous examples, the devices located in other power distribution equipment enclosures are synchronized from a nearby SER, using the protocol needed.

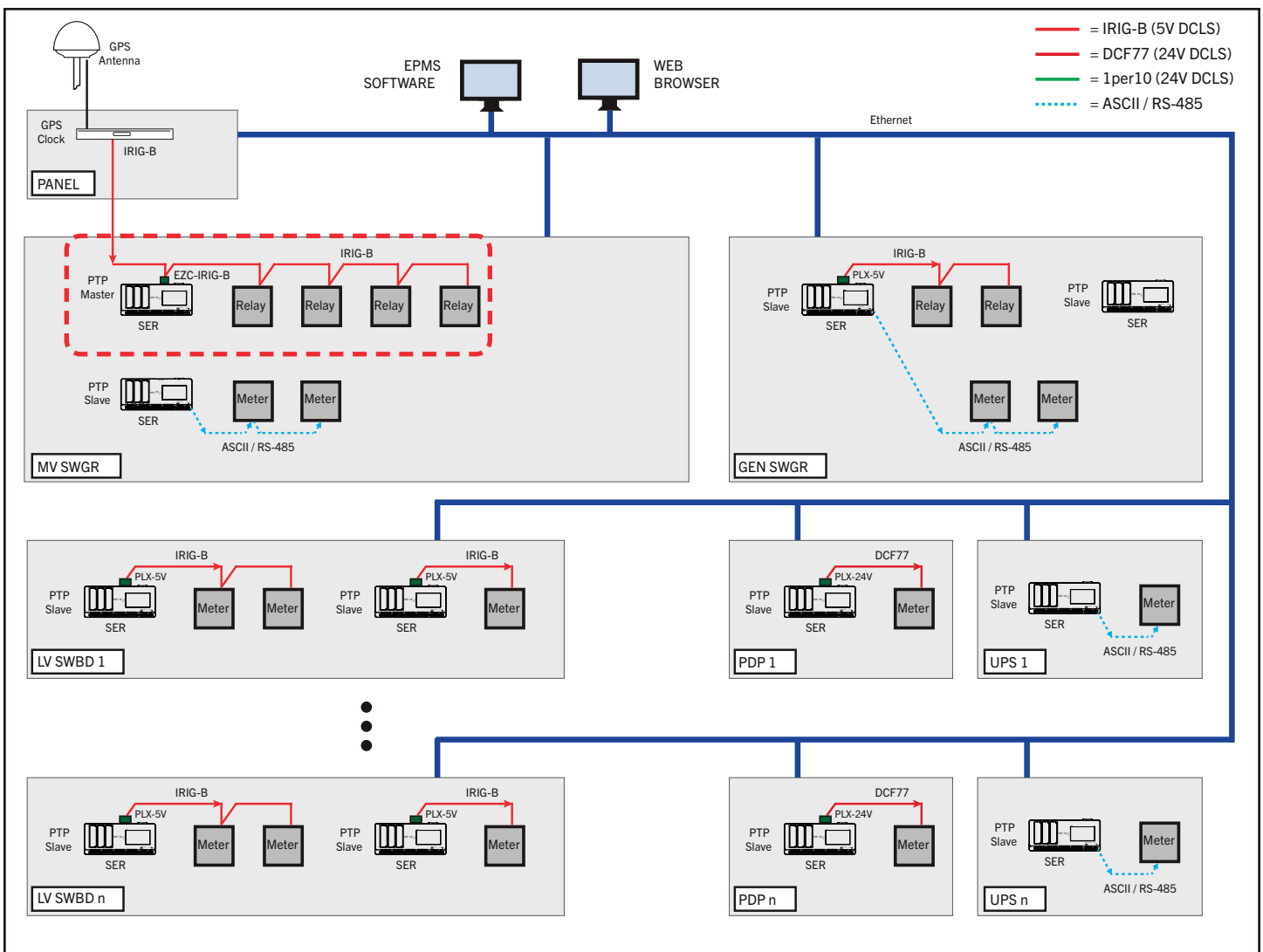

EPMS SYSTEM EXAMPLE—High-def time-sync over Ethernet using PTP; first SER is in MV switchgear (IRIG-B time source from GPS clock)

## EPMS SYSTEM EXAMPLE

### (Sync 2 or more SERs via IRIG-B: PTP Master and PTP Standby Master)

The final example shown below takes the system architecture of the last example one important step further.

**Time Source.** In addition to the first SER, a second Trystar SER also accepts IRIG-B as its time source from the GPS clock. In this design, both SERs are configured as a PTP master using the same PTP domain number. Using the IEEE 1588 “Best Master Clock” algorithm, one SER automatically acts as the PTP grandmaster clock, and the other waits in standby mode in case it is ever needed as a backup.

**Time Distribution.** The first SER or the backup SER serves as PTP grandmaster for all other Trystar SERs (PTP slaves), synchronized within 100  $\mu$ sec of each other. If the first clock fails or goes offline, the backup PTP master becomes the grandmaster clock automatically and remains in service until the other is restored. This ensures reliable, uninterrupted time service to all devices.

**Time Conversion.** As in previous examples, the devices located in other power distribution equipment enclosures are synchronized from a nearby SER, using the protocol needed.

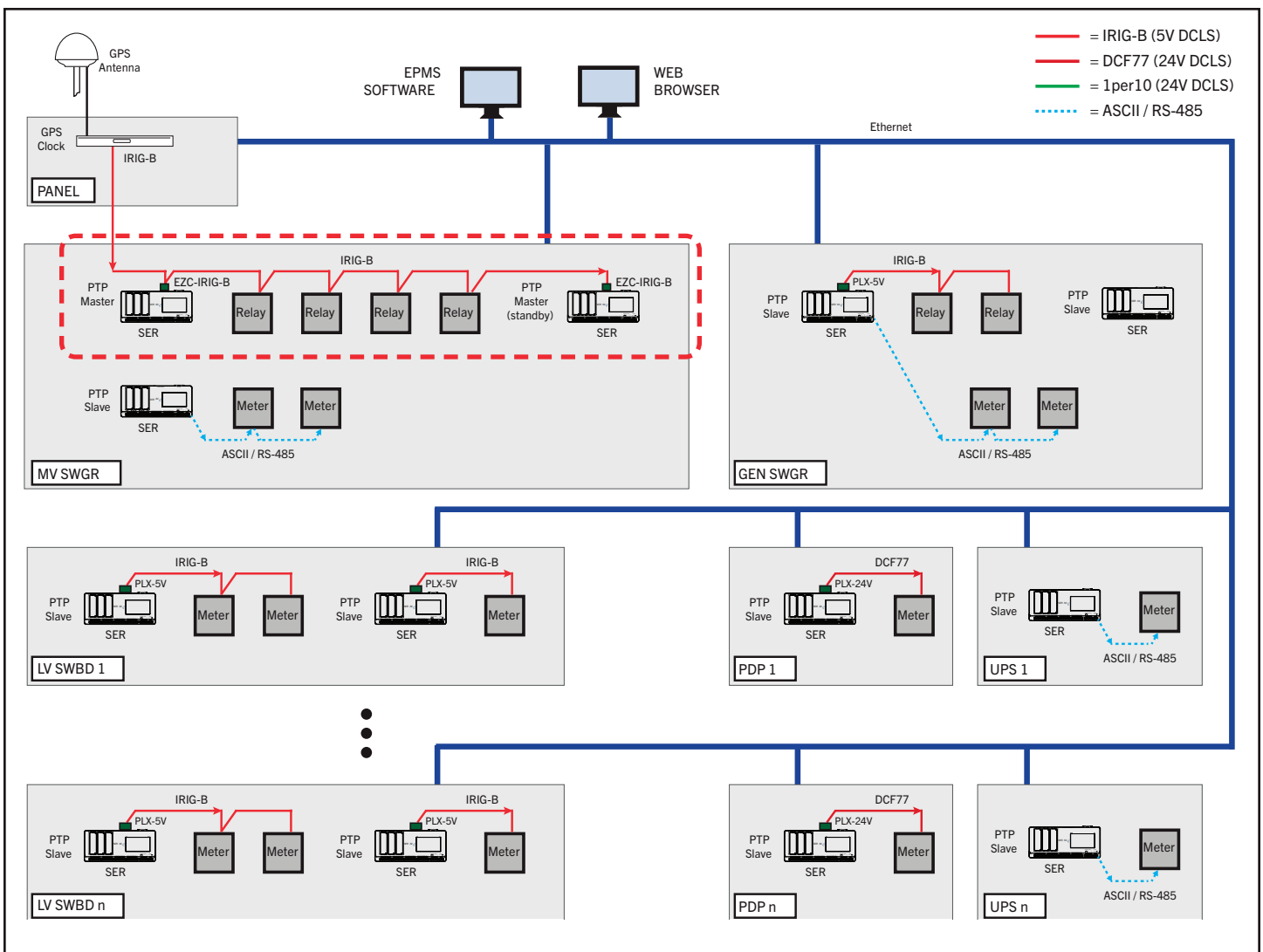

EPMS SYSTEM EXAMPLE—High-def time-sync over Ethernet using PTP; two SERs accept IRIG-B from GPS clock, one is PTP master, other is standby

## SUMMARY

Modern power monitoring systems require 1-msec timestamping, and so “hi-def” time sync (accuracy <100 μs) is essential. SER devices record the exact time of power system events (to 1 msec), enabling root-cause analysis, identifying slow breakers and allowing operators to verify proper system operation. Until recently, separate cabling (often involving multiple protocols) was needed, limiting the benefits to only the largest projects.

Precision Time Protocol (PTP), defined in IEEE 1588 offers a solution to deliver hi-def time synchronization over Ethernet. The key is hardware-assisted time-stamping embedded in the Ethernet 1588 physical interface. However, most of the initial attention to PTP has focused on its potential for achieving very high precision (1 μs or better). The Power Profile, defined in IEEE C37.238, is ostensibly intended for all “power system applications” but in reality is best-suited to substation automation, primarily for electric utilities, with a stated accuracy goal of 1 μs. The resulting characteristics make it unnecessarily strict for industrial/commercial power systems, for which accuracy on the order of 100 μsec is acceptable. Trystar has proposed a “Simple PTP” Profile optimized for power system applications on the demand side of the electric meter.

Simple PTP (SPTP) makes PTP relevant for commercial/industrial power systems, including data centers, hospitals and microgrids. In addition, this extends the benefits of precision timing to a much broader market, even those previously forced to compromise requirements to keep costs low. The PTP-enabled solution is simple, affordable and completely scalable, from a few devices to the largest installation. Now engineers can expect more from their investment in EPMS and know what happened and when—to one millisecond—and without all the extra wires.

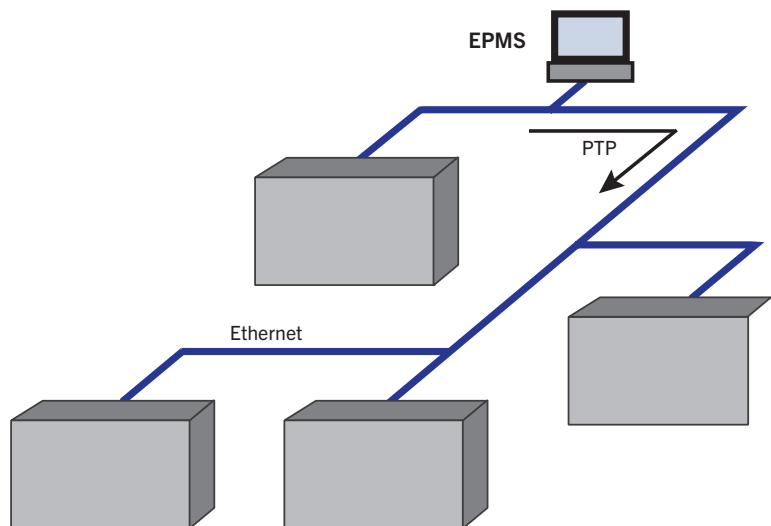

*High-resolution time-sync over Ethernet using PTP—no extra field wiring between equipment lineups*

## REFERENCES

### References

1. IEEE Std 1588™-2008, IEEE Standard for a Precision Clock Synchronization Protocol for Networked Measurement and Control Systems. IEEE Std 1588-2019, “IEEE Standard for a Precision Clock Synchronization Protocol for Networked Measurement and Control Systems,” 7 November 2019
2. IEEE Std C37.238-2011, IEEE Standard Profile for Use of IEEE 1588™ Precision Time Protocol in Power System Applications
3. Kennedy, Robert A., P.E., “GPS Time Synchronization: How precision timing and sequence of events recording will make the Smart Grid even smarter,” *Electrical Construction & Maintenance (EC&M) magazine*, August 19, 2011, pp. 18-20.  
<http://ecmweb.com/computers-amp-software/gps-time-synchronization>
4. Brown, PE, Bill, and Mark Kozlowski, “Power System Event Reconstruction Technologies for Modern Data Centers,” Square D Critical Power Competency Center. Aug. 2006.
5. Dickerson, Bill, P.Eng., Arbiter Systems, Inc. “Time in the Power Industry: How and Why We Use It.”  
<http://www.arbiter.com/solutions/event-time-and-reconstruction.php>
6. “IEEE Standard for SCADA and Automation Systems,” IEEE Std C37.1-2007 (Revision of IEEE Std C37.1-1994).
7. NERC North American Electric Reliability Corporation “Security Guideline for the Electricity Sector: Time Stamping of Operational Data Logs” 009-11-11
8. Dickerson, Bill, “Substation Time Synchronization,” PAC Summer 2007, pp 39-45.
9. Moore, Roger, “Time Synchronization with IEEE 1588,” PAC Summer 2009, pp 47-51.
10. Arnold, Doug and Debbie Henderson, Symmetricom, “Profile for Use of IEEE 1588 Precision Time Protocol in Power System Applications” March 26, 2013.
11. Symmetricom White Paper: “Profile for the Use of the Precision Time Protocol in Power Systems” 2013. [www.symmetricom.com](http://www.symmetricom.com)
12. RFC-5905 “Network Time Protocol Version 4: Protocol and Algorithms Specification” <http://www.ntp.org>
13. Muschlitz, Bruce A., and Gary M. Nelson, “Better Time Synchronization in IEC61850 Networks.”

14. Eidson, John C., Measurement, Control and Communications Using IEEE 1588, Springer-Verlag, London. 2006.
15. Laird, Jeff, “Clock Synchronization Terminology,” InterOperability Laboratory, University of New Hampshire, June 2012.

