

INSTRUCTION BULLETIN
REFERENCE GUIDE

CyTime™
Sequence of Events Recorder
SER-32e

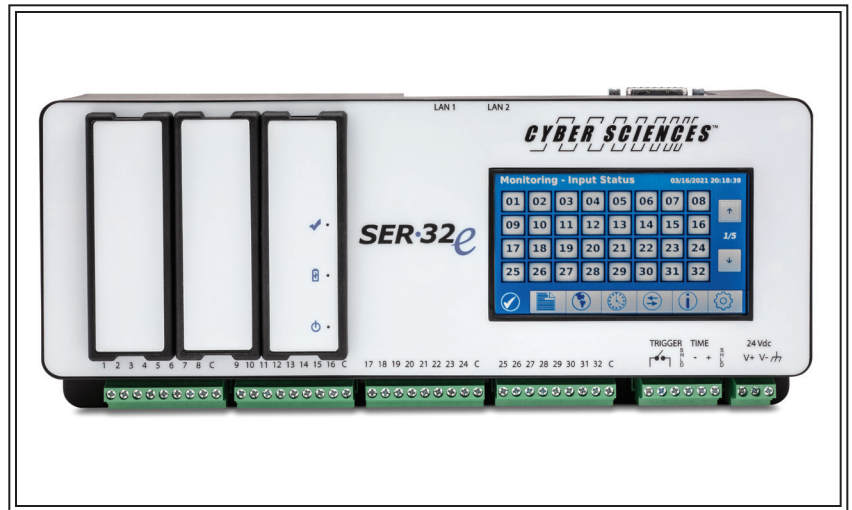

TABLE OF CONTENTS



See Also—SER User’s Guide:

- *Product Overview*
- *Installation*
- *Wiring*
- *Local Display and Keypad*
- *Setup & Monitoring via Web Pages*
- *Specifications*

1—ETHERNET COMMUNICATIONS	1
Ethernet Protocols Supported	1
Modbus Addressing Conventions	1
Modbus Memory Map	2
Byte Order	3
Date/Time Conventions	3
2—MODBUS REGISTER LIST	4-19
3—ACCESSING THE SER EVENT LOG	20
Event Log Contents	20
File Record Access	20
Event Log Registers	21
Record Sequence Numbers	22
Event Codes	22
Type 2 Buffer (Compatibility Mode)	23
Compatibility Registers	23
4—ACCESSING EPSS DATA LOGS	24
EPSS Data Log Overview	24
EPSS Data Log File Structure	25
5—COMMAND INTERFACE	26
Description	26
Command Interface Example 1: Clear Event Log	27
Command Interface Example 2: Initiate Auto Test	27
6—XML SETUP FILE	28
Setup File Overview	28
XML Setup File Example	28
7—RESTFUL API	30
Overview	30
HTTP GET Supported Commands	30
HTTP GET Command Descriptions	31
HTTP GET Example Use	32
How to Get Events	33
8—PRECISION TIME PROTOCOL (PTP)	35
Precision Time Protocol (per IEEE 1588™)	35
PTP Settings and Attributes Supported	36
Timescales and Leap Seconds	37
Adjusting for Local Time Zone	37
Daylight Saving Time (DST)	39
9—TROUBLESHOOTING	40

SAFETY PRECAUTIONS

Important safety precautions must be followed before attempting to install, service, or maintain electrical equipment. Carefully read and follow the safety precautions outlined below.

DANGER

HAZARD OF ELECTRIC SHOCK, EXPLOSION, OR ARC FLASH

- Only qualified workers should install this equipment. Such work should be performed only after reading this entire set of instructions.
- NEVER work alone.
- Before performing visual inspections, tests, or maintenance on this equipment, disconnect all sources of electric power. Assume that all circuits are live until they have been completely de-energized, tested, and tagged. Pay particular attention to the design of the power system. Consider all sources of power, including the possibility of backfeeding.
- Apply appropriate personal protective equipment (PPE) and follow safe electrical practices. For example, in the USA, see NFPA 70E.
- Turn off all power supplying the equipment in which the device is to be installed before installing and wiring the device.
- Always use a properly rated voltage sensing device to confirm that power is off.
- Beware of potential hazards, wear personal protective equipment, and carefully inspect the work area for tools and objects that may have been left inside the equipment.
- The successful operation of this equipment depends upon proper handling, installation, and operation. Neglecting fundamental installation requirements may lead to personal injury as well as damage to electrical equipment or other property.

Failure to follow these instructions can result in death or serious injury.

NOTE:

Electrical equipment should be serviced by qualified personnel. No responsibility is assumed by Cyber Sciences, Inc. for any consequences arising out of the use of this material. This document is not intended as an instruction manual for untrained persons.

1—ETHERNET COMMUNICATIONS

Ethernet Protocols Supported

Note: This instruction bulletin describes product features and behaviors for the latest firmware version available at the time of publication. Cyber Sciences recommends updating to the latest firmware whenever feasible, available for free download:

www.cyber-sciences.com/downloads

The CyTime™ SER-32e Sequence of Events Recorder supports the following Ethernet protocols:

- **Hypertext Protocol Secure (HTTPS):** HTTPS is a networking protocol used by web browsers to access and present data over a secure network. The CyTime SER uses HTTPS to provide secure web server functionality using TLS version 1.3 with 256-bit encryption over TCP port 443 (default).
- **Modbus TCP:** Modbus TCP is a combination of the Modbus protocol, which provides master-slave communication between devices, and TCP/IP, which provides communications over an Ethernet connection. Modbus TCP can be used by application software, PLCs, or other master devices to access data or send commands to the SER, using TCP port 502.

Note: Connections (“Modbus TCP Sockets”) that remain idle for 75 seconds and then fail to acknowledge after three (3) retries are closed automatically (TCP keep-alives).

- **Network Time Protocol (NTP):** NTP is a time protocol used to synchronize clocks of networked devices to a time reference provided by an NTP time server, using UDP port 123.
- **Precision Time Protocol (PTP):** PTP, defined in IEEE Std. (1588-2008/2019), takes advantage of special time-stamping Ethernet hardware to distribute a precise time reference over Ethernet, ensuring time accuracies of 100 μs or better. The PTP “grandmaster” broadcasts precise date/time and network delay correction data to PTP slaves using UDP ports 319 (ptp-event) and 320 (ptp-general) via multicast IP address 224.0.1.129.

Modbus Addressing Conventions

The standard Modbus data model consists of four data tables, and a convention used by most manufacturers is to add a single-digit prefix to indicate register type:

0xxxx — Discrete Output Coils (000001 to 065536)

1xxxx — Discrete Input Contacts (100001 to 165536)

3xxxx — Input Registers (300001 to 365536)

4xxxx — Holding Registers (400001 to 465536)

In this convention, register references use a 1-index, while the actual values used in the data address field of Modbus messages are 0-based (0 to 65535). Thus, a holding register reference number **400201** would be read with function code 03 at data address field **0200**.

In this document, all Modbus registers are expressed using this de facto convention (single-digit prefix to indicate register type, plus offset of 1 from the data address used in the actual Modbus message).

Modbus Memory Map

Note: The SER-32e responds to ID=1 in the “unit identifier” field in the Modbus Application Protocol header.

The CyTime SER-32e provides access to real-time data, configuration values and event records via Ethernet using Modbus TCP protocol. The SER supports Modbus function codes 01, 02, 03, 05, 06, 16 and 20. Up to 44 concurrent Modbus TCP connections are supported. All registers in the SER are read-only holding registers unless otherwise noted.

The SER-32e features a non-volatile event log for SER applications and a second data logging space for Emergency Power Supply Systems (EPSS) reporting. The Modbus memory map contains all the required data to support both functions, as illustrated below.

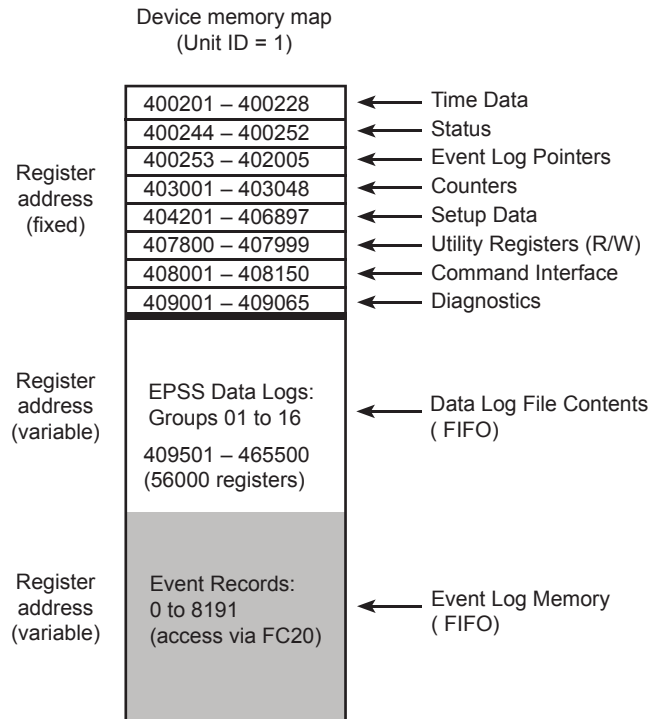

The CyTime SER-32e primary register map is organized into a fixed-register section with designated data fields and two variable memory sections—the first for EPSS data logs and the second for event records, accessible using Function Code 20. The EPSS data log area consists of sixteen (16) user-configurable data log groups to enable EPSS reporting. The record size depends on the number of channels assigned to the group by the user. Up to 56000 registers can be allocated by the user to all data logs.

For sequence of events recording (SER) a total of 8192 events are stored in non-volatile memory; each event record consists of 8 registers. Additional details are provided in the next sections. See the figure above and the next sections for details.

Byte Order

Note: Where applicable, the SER uses “big-endian” encoding, consistent with Modbus standards. That is, the most significant byte or word is stored in the first position, or lowest register. The one exception is the event log—here encoding is reversed (“little-endian”) to maintain compatibility with legacy event recorders.

Modbus protocol is based on 16-bit registers, each of which can contain up to 2 bytes. Unsigned values greater than 65535 are encoded as 32-bit integers using 2 registers, 4 bytes total. The order in which these bytes are stored must therefore be known for the data to be retrieved and correctly interpreted. Modbus declares itself as a ‘big-endian’ protocol, per Modbus Application Protocol Specification, V1.1.b:

“Modbus uses a ‘big-endian’ representation for addresses and data items. This means that when a numerical quantity larger than a single byte is transmitted, the most significant byte is sent first.”

Following this convention, the SER stores all values as “big-endian” except where noted otherwise.

A copy of the Modbus protocol specification is available for free download from the Modbus web site: www.modbus.org/specs.php.

Date/Time Conventions

The CyTime SER-32e provides a user-configurable setting for time zone offset: the time in hours to add to or subtract from Coordinated Universal Time (UTC) to adjust for local time.

The CyTime SER supports adjustments for Daylight Saving Time (DST) or Summer Time. However, Cyber Sciences recommends that event timestamps be based exclusively on UTC or standard time, since discontinuities introduce potential for confusion and make comparisons of historical values more difficult. If an adjustment for DST is desired, this should be made by application software at the end point of consumption (for display or analysis). This topic is discussed in more detail later in this document.

Three (3) different conventions are used by the SER to store the current date/time, depending on the context:

- **Expanded (7-register) format**, in which each element (year, month, day, hour, minute, second), is stored in a separate register. Example: present date/time, in registers 400203 to 400209.
- **Condensed (3 or 4-register) format**, in which two elements are stored per register (month/day in MSB/LSB, year/hour in next register, etc.). The 4th register (for milliseconds) is optional. See Table 1-1 below for details. Example: present date/time, condensed, in registers 400210 to 400212.
- **Compressed (2-register, 32-bit unsigned integer) format**, in which the date/time is expressed in seconds since the “epoch” date of Jan 1, 1984. Example: SER event log, registers 3 and 4 in each event record.

Table 1-1 – Condensed Date/Time Format (with optional ms)

	High-byte (MSB)	Low-byte (LSB)
register 1	Month (0 - 12)	Day (0 - 31)
register 2	Year (0 - 199) (add 1900)	Hour (0 - 23)
register 3	Minute (0 - 59)	Second (0- 59)
register 4 (optional)	Milliseconds (0 - 999)	

Note: To get the year, add 1900 to the value in register 2 high-byte (e.g., a value of 112 in register 2/high-byte represents 112 + 1900 = the year 2012).

2—MODBUS REGISTER LIST

Register (ID = 1)	Description	Type	Range	Notes
400101	Daylight Saving Time (DST) is in effect	integer	0 or 1	0 = false 1 = true ①
400201	Time source (actual)	integer	0 to 32	0 = None (manual / external) 1 = NTP 2 = IRIG-B 4 = Inter-SER (IRIG-B) 8 = DCF77 16 = Inter-SER (DCF77) 32 = PTP (IEEE 1588)
400203	Present day of week	integer	1 to 7	1 = Sunday, 2 = Monday, etc.
400204	Present month	integer	1 to 12	
400205	Present day of month	integer	1 to 31	
400206	Present year	integer	2000 to 2120	
400207	Present hour	integer	0 to 23	
400208	Present minute	integer	0 to 59	
400209	Present second	integer	0 to 59	
400210 to 400212	Present Date/Time (condensed format)	3-register date/time	Jan 1, 2000 to Dec 31, 2120	Condensed date/time format, without ms (see Table 1-1)
400213	Last NTP sync, day of week	integer	1 to 7	1 = Sunday, 2 = Monday, etc.
400214	Last NTP sync, month	integer	1 to 12	
400215	Last NTP sync, day of month	integer	1 to 31	
400216	Last NTP sync, year	integer	2000 to 2120	
400217	Last NTP sync, hour	integer	0 to 23	
400218	Last NTP sync, minute	integer	0 to 59	
400219	Last NTP sync, second	integer	0 to 59	
400222	Time quality (see note on previous page for time source = NTP)	integer	0 to 3	0 = Good (< 1 ms error) 1 = Fair (< 50 ms error) 2 = Poor (> 50 ms error) 3 = Bad (no time sync)
400225 to 400228	Last NTP sync, server IP address, octet 1 to 4 (MSB to LSB)	integer	0 to 255	
400229	PTP Port State	integer	0 to 9	0 = Not Applicable 1 = Initializing 2 = Faulty 3 = Disabled 4 = Listening 5 = Pre-master 6 = Master 7 = Passive 8 = Uncalibrated 9 = Slave

① This register is set to 1 (true) if DST is enabled and the current date/time is within the specified DST interval (between start and end date/time).

Register (ID = 1)	Description	Type	Range	Notes
400230	PTP Clock Class	integer	0 to 255	00 = Not Applicable 06 = Normal (PTP Timescale) 07 = Holdover (PTP) 13 = Normal (UTC Timescale) 14 = Holdover (UTC) 52 = Out-of-spec (PTP) 58 = Out-of-spec (UTC) 255 = Slave-only
400231	PTP Clock Accuracy	integer	0 to 254	00 (0x00) = Not Applicable 32 (0x20) = 25 ns 33 (0x21) = 100 ns 39 (0x27) = 100 μs 41 (0x29) = 1 ms 43 (0x2B) = 10 ms 45 (0x2D) = 100 ms 47 (0x2F) = 1s 49 (0x31) = >10s 254 (0xFE) = unknown
400232	PTP Clock Source (PTP Time Source)	integer	0 to 255	00 (0x00) = Unknown 16 (0x10) = Atomic clock 32 (0x20) = GPS 64 (0x40) = PTP 80 (0x50) = NTP 96 (0x60) = Hand-set (manual) 144 (0x90) = Other 160 (0xA0) = Internal (none)
400233	<i>reserved</i>			
400234	<i>reserved</i>			
400235	<i>reserved</i>			
400236	PTP communications model	integer	1 or 2	1 = Unicast 2 = Multicast
400237	PTP network transport protocol	integer	0, 1 or 2	0 = UDPv4 1 = UDPv6 2 = 802.3 (Layer 2)
400238	PTP operating mode	integer	1 or 2	2 = two-step 1 = one-step
400239	PTP path delay mechanism	integer	0, 1 or 2	0 = disabled 1 = End-to-End (E2E) 2 = Peer-to-Peer (P2P)
400240	PTP announce interval (master)	signed integer	0 to 4 (1 to 16 sec.) Default = 1 (2 sec.)	log-base2 of value in seconds ①
400241	PTP announce receipt time-out (master)	integer	2 to 10 Default = 3	multiple of announce interval
400242	PTP sync interval (master)	signed integer	-1 to 1 (0.5 to 2 sec.) Default = 0 (1 sec.)	log-base2 of value in seconds ①
400243	PTP delay request interval (master)	signed integer	0 to 5 (1 to 32 sec.) Default = 0 (1 sec.)	log-base2 of value in seconds ①

① Please see Section 8 for more details on the convention used in IEEE 1588 to express interval settings in terms of log-base2.

Register (ID = 1)	Description	Type	Range	Notes
400244	Forced OFF—Channels 1 to 16 (Inputs 1-16)	bitmap	0x0000 – 0xFFFF	0 = Normal, 1 = Forced OFF bit 00 – Input 1 bit 01 – Input 2 bit 02 – Input 3 : bit 15 – Input 16
400245	Forced OFF—Channels 17 to 32 (Inputs 17-32)	bitmap	0x0000 – 0xFFFF	0 = Normal, 1 = Forced OFF bit 00 – Input 17 bit 01 – Input 18 bit 02 – Input 19 : bit 15 – Input 32
400246	Forced ON—Channels 1 to 16 (Inputs 1-16)	bitmap	0x0000 – 0xFFFF	0 = Normal, 1 = Forced ON bit 00 – Input 1 bit 01 – Input 2 bit 02 – Input 3 : bit 15 – Input 16
400247	Forced ON—Channels 17 to 32 (Inputs 17-32)	bitmap	0x0000 – 0xFFFF	0 = Normal, 1 = Forced ON bit 00 – Input 17 bit 01 – Input 18 bit 02 – Input 19 : bit 15 – Input 32
400248	Inversion of Inputs (Inputs 1-16)	bitmap	0x0000 – 0xFFFF	0 = Normal, 1 = Inverted bit 00 – Input 1 bit 01 – Input 2 bit 02 – Input 3 : bit 15 – Input 16
400249	Inversion of Inputs (Inputs 17-32)	bitmap	0x0000 – 0xFFFF	0 = Normal, 1 = Inverted bit 00 – Input 17 bit 01 – Input 18 bit 02 – Input 19 : bit 15 – Input 32

Register	Description	Type	Range	Notes
(ID = 1)	STATUS			
400250	<i>reserved</i>			
400251	Status—Channels 1 to 16 (Inputs 1-16)	bitmap	0x0000 – 0xFFFF	0 = OFF, 1 = ON bit 00 – Input 1, bit 01 – Input 2 bit 02 – Input 3 : bit 15 – Input 16
400252	Status—Channels 17 to 32 (Inputs 17-32)	bitmap	0x0000 – 0xFFFF	0 = OFF, 1 = ON bit 00 – Input 17, bit 01 – Input 18 bit 02 – Input 19 : bit 15 – Input 32
400260 to 400267	PTP Clock ID	character array		
EVENT LOG REGISTERS				
400253	Number of events in event log	integer	1 to 8192	
400254	Position of first event record	integer	0 to 8191	
400255	Position of last event record	integer	0 to 8191	
400256 to 400257	Sequence number of last event record	32-bit integer	0 to 4,294,967,295	note: reg 400256 = high word (big-endian—MSW first)
400270	Status - Channels 33-48 (Input or Output depending on configuration)	bitmap	0x0000 – 0xFFFF	0 = Normal, 1 = Forced OFF bit 00 – Chan 33 bit 01 – Chan 34 bit 02 – Chan 35 : bit 15 - Chan 48
400271	Forced OFF—Channels 33 to 48 (Inputs or outputs)	bitmap	0x0000 – 0xFFFF	0 = Normal, 1 = Forced ON bit 00 – Chan 33 bit 01 – Chan 34 bit 02 – Chan 35 : bit 15 - Chan 48
400272	Forced ON—Channels 33 to 48 (inputs or outputs)	bitmap	0x0000 – 0xFFFF	0 = Normal, 1 = Inverted 00 – Chan 33 bit 01 – Chan 34 bit 02 – Chan 35 : bit 15 - Chan 48
400273	Inversion of Inputs (Inputs 33 to 48) (only applies to inputs)	bitmap	0x0000 – 0xFFFF	bit 00 – Chan 33 bit 01 – Chan 34 bit 02 – Chan 35 : bit 15 - Chan 48
400274-299	<i>reserved</i>			
EVENT LOG REGISTERS (Duplicate set)				
402001	Number of events in event log	integer	1 to 8192	
402002	Position of first event record	integer	0 to 8191	
402003	Position of last event record	integer	0 to 8191	
402004 to 402005	Sequence number of last event record	32-bit integer	0 to 4,294,967,295	note: reg 402004 = high word (big-endian—MSW first)

Register	Description	Type	Range	Notes
(ID = 1)	DATA LOG FILE TABLE OF CONTENTS LOCATIONS			
402020	Group 01		(see below)	block of 20 registers total
402040	Group 02			
402060	Group 03			
402080	Group 04			
402100	Group 05			
402120	Group 06			
402140	Group 07			
402160	Group 08			
402180	Group 09			
402200	Group 10			
402220	Group 11			
402240	Group 12			
402260	Group 13			
402280	Group 14			
402300	Group 15			
402320	Group 16			
	DATA LOG FILE TOC DETAILS (typical for 16)			
base + 0	File Header Location (register number)	integer	9501 to 65535 (409501 to 465535)	starting register number of header for a given group (65535 = log file not used)
base + 1	File Type	integer	0 or 1	fixed = 1 (data log)
base + 2	File Size (total allocated), in records	integer	0 to 14000	
base + 3	Record Length (Number of registers per record)	integer	5 to 14	max group members = 10
base + 4	File Mode	integer	fixed = 1	1 = FIFO
base + 5	Record Entry Enable/Disable	integer	0x0000 to 0xFFFF	0x0000 = disabled 0xFFFF = enabled
base + 6	Entry Update Interval	integer	0 to 65535	not used (fixed = 0)
base + 7	Entry Interval Offset Time	integer	0 to 65535	not used (fixed = 0)
base + 8	Current No. of Records in File	integer	0 to 14000	
base + 9	Current First Record Sequence	integer	0 to 14000	pointer—oldest s/n
base + 10	Current Last Record Sequence	integer	0 to 14000	pointer—latest s/n
base + 11 to 13	Date/Time of Last File Reset/Clear (if event log cleared or EPSS data logs re-configured)	3-register date/time	Jan 1, 2000 to Dec 31, 2120	Condensed date/time format, without ms (see Table 1-1)
base + 14	File Size (total allocated), in records	integer	0 to 14000	(same as base + 2)
base + 15	Record Length (Number of registers per record)	integer	5 to 14	(same as base + 3)
base + 16	File Status (actual vs. allocated)	integer	0 to 255	0 = ok 1 = internal failure 255 = file disabled due to invalid configuration
base + 17	Data Location (starting register number of data)	integer	9501 to 65535 (409501 to 465535)	starting register number for the file's data (after header)

Register	Description	Type	Range	Notes
(ID = 1)	OPERATIONS COUNTERS			
403001	Counter—Channel 01 (Input 01)	integer	0 to 65535	
403002	Counter—Channel 02 (Input 02)	integer	0 to 65535	
403003	Counter—Channel 03 (Input 03)	integer	0 to 65535	
403004	Counter—Channel 04 (Input 04)	integer	0 to 65535	
403005	Counter—Channel 05 (Input 05)	integer	0 to 65535	
403006	Counter—Channel 06 (Input 06)	integer	0 to 65535	
403007	Counter—Channel 07 (Input 07)	integer	0 to 65535	
403008	Counter—Channel 08 (Input 08)	integer	0 to 65535	
403009	Counter—Channel 09 (Input 09)	integer	0 to 65535	
403010	Counter—Channel 10 (Input 10)	integer	0 to 65535	
403011	Counter—Channel 11 (Input 11)	integer	0 to 65535	
403012	Counter—Channel 12 (Input 12)	integer	0 to 65535	
403013	Counter—Channel 13 (Input 13)	integer	0 to 65535	
403014	Counter—Channel 14 (Input 14)	integer	0 to 65535	
403015	Counter—Channel 15 (Input 15)	integer	0 to 65535	
403016	Counter—Channel 16 (Input 16)	integer	0 to 65535	
403017	Counter—Channel 17 (Input 17)	integer	0 to 65535	
403018	Counter—Channel 18 (Input 18)	integer	0 to 65535	
403019	Counter—Channel 19 (Input 19)	integer	0 to 65535	
403020	Counter—Channel 20 (Input 20)	integer	0 to 65535	
403021	Counter—Channel 21 (Input 21)	integer	0 to 65535	
403022	Counter—Channel 22 (Input 22)	integer	0 to 65535	
403023	Counter—Channel 23 (Input 23)	integer	0 to 65535	
403024	Counter—Channel 24 (Input 24)	integer	0 to 65535	
403025	Counter—Channel 25 (Input 25)	integer	0 to 65535	
403026	Counter—Channel 26 (Input 26)	integer	0 to 65535	
403027	Counter—Channel 27 (Input 27)	integer	0 to 65535	
403028	Counter—Channel 28 (Input 28)	integer	0 to 65535	
403029	Counter—Channel 29 (Input 29)	integer	0 to 65535	
403030	Counter—Channel 30 (Input 30)	integer	0 to 65535	
403031	Counter—Channel 31 (Input 31)	integer	0 to 65535	
403032	Counter—Channel 32 (Input 32)	integer	0 to 65535	
403033	Counter — Channel 33 (Input 33 or Output R1)	integer	0 to 65535	
403034	Counter — Channel 34 (Input 34 or Output R2)	integer	0 to 65535	
403035	Counter — Channel 35 (Input 35 or Output R3)	integer	0 to 65535	
403036	Counter — Channel 36 (Input 36 or Output R4)	integer	0 to 65535	
403037	Counter — Channel 37 (Input 37 or Output R5)	integer	0 to 65535	
403038	Counter — Channel 38 (Input 38 or Output R6)	integer	0 to 65535	
403039	Counter — Channel 39 (Input 39 or Output R7)	integer	0 to 65535	
403040	Counter — Channel 40 (Input 40 or Output R8)	integer	0 to 65535	
403041	Counter — Channel 41 (Input 41 or Output R9)	integer	0 to 65535	
403042	Counter — Channel 42 (Input 42 or Output R10)	integer	0 to 65535	

Register	Description	Type	Range	Notes
403043	Counter — Channel 43 (Input 43 or Output R11)	integer	0 to 65535	
403044	Counter — Channel 44 (Input 44 or Output R12)	integer	0 to 65535	
403045	Counter — Channel 45 (Input 45 or Output R13)	integer	0 to 65535	
403046	Counter — Channel 46 (Input 46 or Output R14)	integer	0 to 65535	
403047	Counter — Channel 47 (Input 47 or Output R15)	integer	0 to 65535	
403048	Counter — Channel 48 (Input 48 or Output R16)	integer	0 to 65535	

Register	Description	Type	Range	Notes
(ID = 1)	DATE/TIME OF LAST RESET, COUNTERS			
403301 to 403303	Date/Time of Last Reset—Channel 01 (Input 01)	3-register date/time	Jan 1, 2000 to Dec 31, 2120	See Table 1-1 for details
403304 to 403306	Date/Time of Last Reset—Channel 02 (Input 02)	3-register date/time	Jan 1, 2000 to Dec 31, 2120	
403307 to 403309	Date/Time of Last Reset—Channel 03 (Input 03)	3-register date/time	Jan 1, 2000 to Dec 31, 2120	
403310 to 403312	Date/Time of Last Reset—Channel 04 (Input 04)	3-register date/time	Jan 1, 2000 to Dec 31, 2120	
403313 to 403315	Date/Time of Last Reset—Channel 05 (Input 05)	3-register date/time	Jan 1, 2000 to Dec 31, 2120	
403316 to 403318	Date/Time of Last Reset—Channel 06 (Input 06)	3-register date/time	Jan 1, 2000 to Dec 31, 2120	
403319 to 403321	Date/Time of Last Reset—Channel 07 (Input 07)	3-register date/time	Jan 1, 2000 to Dec 31, 2120	
403322 to 403324	Date/Time of Last Reset—Channel 08 (Input 08)	3-register date/time	Jan 1, 2000 to Dec 31, 2120	
403325 to 403327	Date/Time of Last Reset—Channel 09 (Input 09)	3-register date/time	Jan 1, 2000 to Dec 31, 2120	
403328 to 403330	Date/Time of Last Reset—Channel 10 (Input 10)	3-register date/time	Jan 1, 2000 to Dec 31, 2120	
403331 to 403333	Date/Time of Last Reset—Channel 11 (Input 11)	3-register date/time	Jan 1, 2000 to Dec 31, 2120	
403334 to 403336	Date/Time of Last Reset—Channel 12 (Input 12)	3-register date/time	Jan 1, 2000 to Dec 31, 2120	
403337 to 403339	Date/Time of Last Reset—Channel 13 (Input 13)	3-register date/time	Jan 1, 2000 to Dec 31, 2120	
403340 to 403342	Date/Time of Last Reset—Channel 14 (Input 14)	3-register date/time	Jan 1, 2000 to Dec 31, 2120	
403343 to 403345	Date/Time of Last Reset—Channel 15 (Input 15)	3-register date/time	Jan 1, 2000 to Dec 31, 2120	
403346 to 403348	Date/Time of Last Reset—Channel 16 (Input 16)	3-register date/time	Jan 1, 2000 to Dec 31, 2120	
403349 to 403351	Date/Time of Last Reset—Channel 17 (Input 17)	3-register date/time	Jan 1, 2000 to Dec 31, 2120	
403352 to 403354	Date/Time of Last Reset—Channel 18 (Input 18)	3-register date/time	Jan 1, 2000 to Dec 31, 2120	
403355 to 403357	Date/Time of Last Reset—Channel 19 (Input 19)	3-register date/time	Jan 1, 2000 to Dec 31, 2120	

Register	Description	Type	Range	Notes
(ID = 1)	DATE/TIME OF LAST RESET, COUNTERS (CONT.)			
403358 to 403360	Date/Time of Last Reset—Channel 20 (Input 20)	3-register date/time	Jan 1, 2000 to Dec 31, 2120	
403361 to 403363	Date/Time of Last Reset—Channel 21 (Input 21)	3-register date/time	Jan 1, 2000 to Dec 31, 2120	
403364 to 403366	Date/Time of Last Reset—Channel 22 (Input 22)	3-register date/time	Jan 1, 2000 to Dec 31, 2120	
403367 to 403369	Date/Time of Last Reset—Channel 23 (Input 23)	3-register date/time	Jan 1, 2000 to Dec 31, 2120	
403370 to 403372	Date/Time of Last Reset—Channel 24 (Input 24)	3-register date/time	Jan 1, 2000 to Dec 31, 2120	
403373 to 403375	Date/Time of Last Reset—Channel 25 (Input 25)	3-register date/time	Jan 1, 2000 to Dec 31, 2120	
403376 to 403378	Date/Time of Last Reset—Channel 26 (Input 26)	3-register date/time	Jan 1, 2000 to Dec 31, 2120	
403379 to 403381	Date/Time of Last Reset—Channel 27 (Input 27)	3-register date/time	Jan 1, 2000 to Dec 31, 2120	
403382 to 403384	Date/Time of Last Reset—Channel 28 (Input 28)	3-register date/time	Jan 1, 2000 to Dec 31, 2120	
403385 to 403387	Date/Time of Last Reset—Channel 29 (Input 29)	3-register date/time	Jan 1, 2000 to Dec 31, 2120	
403388 to 403390	Date/Time of Last Reset—Channel 30 (Input 30)	3-register date/time	Jan 1, 2000 to Dec 31, 2120	
403391 to 403393	Date/Time of Last Reset—Channel 31 (Input 31)	3-register date/time	Jan 1, 2000 to Dec 31, 2120	
403394 to 403396	Date/Time of Last Reset—Channel 32 (Input 32)	3-register date/time	Jan 1, 2000 to Dec 31, 2120	
403397 to 403399	Date/Time of Last Reset—Channel 33 (Input 33 or Output R1)	3-register date/time	Jan 1, 2000 to Dec 31, 2120	
403400 to 403402	Date/Time of Last Reset—Channel 34 (Input 34 or Output R2)	3-register date/time	Jan 1, 2000 to Dec 31, 2120	
403403 to 403405	Date/Time of Last Reset—Channel 35 (Input 35 or Output R3)	3-register date/time	Jan 1, 2000 to Dec 31, 2120	
403406 to 403408	Date/Time of Last Reset—Channel 36 (Input 36 or Output R4)	3-register date/time	Jan 1, 2000 to Dec 31, 2120	
403409 to 403411	Date/Time of Last Reset—Channel 37 (Input 37 or Output R5)	3-register date/time	Jan 1, 2000 to Dec 31, 2120	
403412 to 403414	Date/Time of Last Reset—Channel 38 (Input 38 or Output R6)	3-register date/time	Jan 1, 2000 to Dec 31, 2120	
403415 to 403417	Date/Time of Last Reset—Channel 39 (Input 39 or Output R7)	3-register date/time	Jan 1, 2000 to Dec 31, 2120	
403418 to 403420	Date/Time of Last Reset—Channel 40 (Input 40 or Output R8)	3-register date/time	Jan 1, 2000 to Dec 31, 2120	
403421 to 403423	Date/Time of Last Reset—Channel 41 (Input 41 or Output R9)	3-register date/time	Jan 1, 2000 to Dec 31, 2120	
403424 to 403426	Date/Time of Last Reset—Channel 42 (Input 42 or Output R10)	3-register date/time	Jan 1, 2000 to Dec 31, 2120	
403427 to 403429	Date/Time of Last Reset—Channel 43 (Input 43 or Output R11)	3-register date/time	Jan 1, 2000 to Dec 31, 2120	

cont.

Register	Description	Type	Range	Notes
403430 to 403432	Date/Time of Last Reset—Channel 44 (Input 44 or Output R12)	3-register date/time	Jan 1, 2000 to Dec 31, 2120	
403433 to 403435	Date/Time of Last Reset—Channel 45 (Input 45 or Output R13)	3-register date/time	Jan 1, 2000 to Dec 31, 2120	
403436 to 403438	Date/Time of Last Reset—Channel 46 (Input 46 or Output R14)	3-register date/time	Jan 1, 2000 to Dec 31, 2120	
403439 to 403441	Date/Time of Last Reset—Channel 47 (Input 47 or Output R15)	3-register date/time	Jan 1, 2000 to Dec 31, 2120	
403442 to 403444	Date/Time of Last Reset—Channel 48 (Input 48 or Output R16)	3-register date/time	Jan 1, 2000 to Dec 31, 2120	

Register	Description	Type	Range	Notes
(ID = 1)	SETUP DATA—COMMUNICATIONS			
404010	Ethernet media type	integer	0	0 = 10/100BaseTX, Auto
404011	DHCP enabled	integer	0 or 1	0 = disabled 1 = enabled
404012 to 404015	IP address, octet 1 to 4 (MSB to LSB)	integer	0 to 255	LAN 1 (default = 169.254.0.10) LAN 2 (default = 169.254.1.10)
404016 to 404019	Subnet mask, octet 1 to 4 (MSB to LSB)	integer	0 to 255	(default = 255.255.0.0)
404020 to 404023	Default gateway, octet 1 to 4 (MSB to LSB)	integer	0 to 255	(default = 0.0.0.0)
404024 to 404050	<i>reserved</i>			
404051	Modbus Server Enabled	integer	0 or 1	0 = disabled 1 = enabled
404052 to 404101	<i>reserved</i>			
404102 to 404107	Device ID (12 characters, 6 registers)	character array		(default = SER-32e)
404108 to 404123	Device name (32 characters, 16 registers)	character array		(default = CyTime SER-32e)

Register	Description	Type	Range	Notes
(ID = 1)	SETUP DATA—TIME			
404191	Daylight Saving Time (DST) adjustment	integer	0 or 1	0 = disabled 1 = enabled
404192	DST start—month	integer	1 to 12	1 = January, 2 = February, etc.
404193	DST start—week	integer	1 to 5	1st, 2nd, 3rd, 4th or 5th
404194	DST start—day of the week	integer	1 to 7	1 = Sunday, 2 = Monday, etc.
404195	DST start—time (hour)	integer	0 to 23	0 = 00:00 (midnight)
404196	DST end—month	integer	1 to 12	1 = January, 2 = February, etc.
404197	DST end—week	integer	1 to 5	1st, 2nd, 3rd, 4th or 5th
404198	DST end—day of the week	integer	1 to 7	1 = Sunday, 2 = Monday, etc.
404199	DST end—time (hour)	integer	0 to 23	0 = 00:00 (midnight)
404201	Time source (user setting)	integer	0, 1, 2, 3, 4, 5 or 7	0 = IRIG-B (5V DCLS via EZC) 1 = IRIG-B (over RS-485) 2 = NTP 3 = None (manual or external) 4 = DCF77 (24V DCLS via EZC) 5 = DCF77 (over RS-485) 7 = PTP (IEEE 1588) slave
404202	Time sync master (OUT)	integer	0 or 1	0 = disabled 1 = enabled
404203	Time zone offset	integer	-720 to +780	Offset in Minutes
404204	<i>reserved</i>			
404205	Time zone offset: Apply to PLX (IRIG-B, DCF77 or 1per10 time-sync output)	integer	0 or 1	0 = disabled 1 = enabled
404206	Time zone offset: Apply to ASCII (RS-485)	integer	0 or 1	0 = disabled 1 = enabled
404207	Alternate date format	integer	0 or 1	0 = disabled (mm/dd/yyyy) 1 = enabled (dd/mm/yyyy)
404211 to 404214	Primary NTP time server IP address, octet 1 to 4 (MSB to LSB)	integer	0 to 255	(default = 24.56.178.140) (AS4181-TDS Telecom, Fort Collins, Colorado)
404215 to 404218	Secondary NTP time server IP address, octet 1 to 4 (MSB to LSB)	integer	0 to 255	(default = 129.6.15.29) (US National Institute of Standards)
404219	NTP poll interval, in minutes	integer	1 to 10080	1, 2, 5, 10, 15, 30, 60, 120, 240, 480, 720, 1440, 10080 (minutes)
404220	Time sync output (if time sync master enabled)	integer	1 - 7	1 = IRIG-B (over RS-485) 2 = DCF77 (over RS-485) 3 = ASCII (over RS-485) 4 = IRIG-B (via PLX) 5 = DCF77 (via PLX) 6 = 1per10 (via PLX) 7 = PTP (IEEE 1588) master

Register	Description	Type	Range	Notes
(ID = 1)	SETUP DATA—TIME (CONT.)			
404221	PTP version	integer	2 (fixed)	IEEE 1588-2008(v2) / 2019(v2.1)
404222 to 404224	PTP Profile ID	hex	00-1B-19-00-01-00 (fixed)	IEEE 1588 E2E Default Profile (Annex I)
404225	PTP domain number	integer	0 to 127	(default = 0)
404226	PTP communications model	integer	2 (fixed)	1 = Unicast 2 = Multicast
404227	PTP network transport protocol	integer	0 (fixed)	0 = UDPv4, 1 = UDPv6, 2 = 802.3 (Layer 2)
404228	PTP operating mode	integer	2 (fixed)	2 = two-step 1 = one-step
404229	PTP path delay mechanism	integer	1 (fixed)	1 = End-to-End (E2E) 2 = Peer-to-Peer (P2P)
404230	PTP announce interval (master)	signed integer	1 (fixed = 2 sec)	log-base2 of value in seconds ①
404231	PTP announce receipt time-out (master)	integer	3 (fixed)	multiple of announce interval
404232	PTP sync interval (master)	signed integer	0 (fixed = 1 sec)	log-base2 of value in seconds ①
404233	PTP delay request interval (master)	signed integer	5 (fixed = 32 sec)	log-base2 of value in seconds ①
404234	PTP packet time to live (TTL)	integer	64 (fixed)	
404235	PTP priority1	integer	0 to 255	PTP master only
404236	PTP priority2	integer	0 to 255	PTP master only
	SETUP DATA—INPUTS			
404248	Inputs—inverted (Inputs 1-16)	bitmap	0x0000 – 0xFFFF	0 = Normal, 1 = Inverted bit 00 – Input 1 bit 01 – Input 2 bit 02 – Input 3 : bit 15 – Input 16
404249	Inputs—inverted (Inputs 17-32)	bitmap	0x0000 – 0xFFFF	0 = Normal, 1 = Inverted bit 00 – Input 17 bit 01 – Input 18 bit 02 – Input 19 : bit 15 – Input 32

① Please see Section 8 for more details on the convention used in IEEE 1588 to express interval settings in terms of log-base2.

Register	Description	Type	Range	Notes
(ID = 1)	SETUP DATA— INPUTS (CONT.)			
404251	Event recording—Channels 1 to 16 (Inputs 1-16)	bitmap	0x0000 – 0xFFFF	0 = disabled, 1 = enabled bit 00 – Input 1 bit 01 – Input 2 bit 02 – Input 3 : bit 15 – Input 16
404252	Event recording—Channels 17 to 32 (Inputs 17-32)	bitmap	0x0000 – 0xFFFF	0 = disabled, 1 = enabled bit 00 – Input 17 bit 01 – Input 18 bit 02 – Input 19 : bit 15 – Input 32
404253	Event recording—Channels 33 to 48	bitmap	0x0000 – 0xFFFF	0 = disabled, 1 = enabled bit 00 – Channel 33 bit 01 – Channel 34 bit 02 – Channel 35 : bit 15 – Channel 48
404259	Inputs—invited (Inputs 33-48)	bitmap	0x0000 – 0xFFFF	0 = Normal, 1 = Inverted bit 00 – Input 33 bit 01 – Input 34 bit 02 – Input 35 : bit 15 – Input 48
404260	Expansion Slot 1	bitmap	0xFF = Not installed	0xC8 = Input card installed 0xA8 = Output card installed
404261	Expansion Slot 2	bitmap	0xFF = Not installed	0xC8 = Input card installed 0xA8 = Output card installed
404302 to 404333	Inputs 1 to 32—Filter, in ms	integer	0 to 65535	0 = disabled (default = 20ms)
404334 to 404365	Inputs 1 to 32—Debounce, in ms	integer	0 to 65535	0 = disabled (default = 20ms)
404366 to 404397	Inputs 1 to 32—Chatter count	integer	0 to 255	0 = disabled (default = 20ms)
404402 to 404913	Inputs 1 to 32—Input names (32 characters, 16 registers each)	character array		(default = Input xx, where xx = 01-32)
405002 to 405257	Inputs 1 to 32—off text (16 characters, 8 registers each)	character array		(default = OFF)
405302 to 405557	Inputs 1 to 32—on text (16 characters, 8 registers each)	character array		(default = ON)

Register	Description	Type	Range	Notes
405651	High-speed trigger output—Inputs 1 to 16	bitmap	0x0000 – 0xFFFF	0 = disabled (default), 1 = enabled bit 00 – Input 1 bit 01 – Input 2 bit 02 – Input 3 : bit 15 – Input 16
405652	High-speed trigger output—Inputs 17 to 32	bitmap	0x0000 – 0xFFFF	0 = disabled (default), 1 = enabled bit 00 – Input 17 bit 01 – Input 18 bit 02 – Input 19 : bit 15 – Input 32
405653	High-speed trigger output—Inputs 33 to 48	bitmap	0x0000 – 0xFFFF	<i>(applies to inputs only)</i>
405654 to 405669	Channels 33 to 48—Filter, in ms	integer	0 to 65535	0 = disabled
405670 to 405685	Channels 33 to 48—Debounce, in ms	integer	0 to 65535	0 = disabled
405686 to 405701	Channels 33 to 48—Chatter count	integer	0 to 255	0 = disabled
405702 to 405957	Channels 33 to 48—Input or Output names (32 characters, 16 registers each)	character array		
405958 to 406085	Channels 33 to 48—off text (Input or Output) (16 characters, 8 registers each)	character array		
406086 to 406213	Channels 33 to 48—on text (Input or Output) (16 characters, 8 registers each)	character array		
406214 to 406640	<i>reserved</i>			

Register	Description	Type	Range	Notes
(ID = 1)	SETUP—CHANNELS LOG GROUP (CONT.)			
406641	Input 01: Log Group	integer	0 to 32768	0 = None Assigned (default) 1 = Log Group 1 2 = Log Group 2 4 = Log Group 3 8 = Log Group 4 16 = Log Group 5 : 32768 = Log Group 16
406642	Input 02: Log Group	integer	0 to 32768	
406643	Input 03: Log Group	integer	0 to 32768	
406644	Input 04: Log Group	integer	0 to 32768	
406645	Input 05: Log Group	integer	0 to 32768	
406646	Input 06: Log Group	integer	0 to 32768	
406647	Input 07: Log Group	integer	0 to 32768	
406648	Input 08: Log Group	integer	0 to 32768	
406649	Input 09: Log Group	integer	0 to 32768	

Register	Description	Type	Range	Notes
406650	Input 10: Log Group	integer	0 to 32768	
406651	Input 11: Log Group	integer	0 to 32768	
406652	Input 12: Log Group	integer	0 to 32768	
406653	Input 13: Log Group	integer	0 to 32768	
406654	Input 14: Log Group	integer	0 to 32768	
406655	Input 15: Log Group	integer	0 to 32768	
406656	Input 16: Log Group	integer	0 to 32768	
406657	Input 17: Log Group	integer	0 to 32768	
406658	Input 18: Log Group	integer	0 to 32768	
406659	Input 19: Log Group	integer	0 to 32768	
406660	Input 20: Log Group	integer	0 to 32768	
406661	Input 21: Log Group	integer	0 to 32768	
406662	Input 22: Log Group	integer	0 to 32768	
406663	Input 23: Log Group	integer	0 to 32768	
406664	Input 24: Log Group	integer	0 to 32768	
406665	Input 25: Log Group	integer	0 to 32768	
406666	Input 26: Log Group	integer	0 to 32768	
406667	Input 27: Log Group	integer	0 to 32768	
406668	Input 28: Log Group	integer	0 to 32768	
406669	Input 29: Log Group	integer	0 to 32768	
406670	Input 30: Log Group	integer	0 to 32768	
406671	Input 31: Log Group	integer	0 to 32768	
406672	Input 32: Log Group	integer	0 to 32768	
406673	Input 33 OR Output R1: Log Group	integer	0 to 32768	
406674	Input 34 OR Output R2: Log Group	integer	0 to 32768	
406675	Input 35 OR Output R3: Log Group	integer	0 to 32768	
406676	Input 36 OR Output R4: Log Group	integer	0 to 32768	
406677	Input 37 OR Output R5: Log Group	integer	0 to 32768	
406678	Input 38 OR Output R6: Log Group	integer	0 to 32768	
406679	Input 39 OR Output R7: Log Group	integer	0 to 32768	
406680	Input 40 OR Output R8: Log Group	integer	0 to 32768	
406681	Input 41 OR Output R9: Log Group	integer	0 to 32768	
406682	Input 42 OR Output R10: Log Group	integer	0 to 32768	
406683	Input 43 OR Output R11: Log Group	integer	0 to 32768	
406684	Input 44 OR Output R12: Log Group	integer	0 to 32768	
406685	Input 45 OR Output R13: Log Group	integer	0 to 32768	
406686	Input 46 OR Output R14: Log Group	integer	0 to 32768	
406687	Input 47 OR Output R15: Log Group	integer	0 to 32768	
406688	Input 48 OR Output R16: Log Group	integer	0 to 32768	

Register	Description	Type	Range	Notes
(ID = 1)	SETUP DATA—GROUPS			
406740	Total number of groups (as enabled by user)	integer	0 to 16	
406741	Groups 1 to 16 – EPSS data logging disabled/enabled	bitmap	0x0000 – 0xFFFF	0 = disabled (default), 1 = enabled bit 00 – Group 1 bit 01 – Group 2 bit 02 – Group 3 : bit 15 – Group 16
406742 to 406997	Groups 1 to 16 – Group names (32 characters, 16 registers each)	character array		
	UTILITY REGISTERS			
407800 to 407999	Mailbox registers (read/write) for customer use (total of 200 16-bit registers)			
	COMMAND INTERFACE			
408001	Command register (used to initiate all commands)	integer	0 to 65535	See Section 4 for details
408002 to 408150	Additional registers for control parameters or returned data	integer	0 to 65535	
	COMPATIBILITY REGISTERS			
000001 to 400198	Registers supported for backwards compatibility with some legacy devices (by other manufacturers)			See Section 2 for details

Register	Description	Type	Range	Notes
(ID = 1)	DIAGNOSTICS			
409001	Device ID code	integer	32000	32000 = SER-32e
409002	Catalog number code	integer	50	50 = SER-32e
409003	Hardware version	hex	A0 to FF	
409004	Firmware version, FPGA configuration (CFM)	integer	0 to 65535	
409005	Firmware version, FPGA user (UFM)	integer	0 to 65535	
409006	Firmware version, system processor	integer	100 to 999	Divide value by 100
409007	Date of manufacture, month	integer	1 to 12	
409008	Date of manufacture, year	integer	2000 to 2120	
409009	Firmware version, Power Control Module	integer	100 to 999	Divide value by 100
409010	<i>reserved</i>			
409011	IP address type: static or dynamic (actual)	integer	0 or 1	0 = static, 1 = dynamic
409012 to 409015	IP address, octet 1 to 4 (MSB to LSB)	integer	0 to 255	
409016 to 409019	Subnet mask, octet 1 to 4 (MSB to LSB)	integer	0 to 255	

Register	Description	Type	Range	Notes
409020 to 409023	Default gateway, octet 1 to 4 (MSB to LSB)	integer	0 to 255	
409024 to 409025	Serial number	32-bit integer	0 to 4,294,967,295	note: reg 409024 = high word (big-endian—MSW first)
409041	Ethernet port active	Integer	1 or 2	1 = LAN 1, 2 = LAN 2
409042 to 409047	Active ① MAC address (MSB to LSB)	hex	0x0000 to 0xFFFF	format hh-hh-hh-hh-hh-hh
409048	Modbus sockets, number used	integer	0 to 44	
409049	Modbus sockets, number free	integer	0 to 44	
409050	Firmware build number (internal use)	integer	0 to 65535	

① The active port is 1 when cable is plugged into the left port, 2 when it's plugged into the right port, 1 when both have cables plugged in, and 1 when no cables are plugged in.

Register	Description	Type	Range	Notes
(ID = 1)	DIAGNOSTICS			
409051	Device diagnostics, self-test results	bitmap	0x0000 – 0xFFFF	<p><i>OUTPUT MODULE</i> <i>0 = normal, 1 = error</i> <i>bit 00 – set to “1” if any failure</i> <i>bit 01 – Error, event module</i> <i>bit 02 – Error, time module</i> <i>bit 03 – Error, system module</i> <i>bit 04 – DHCP status</i> <i>bit 05 – NTP server</i> <i>bit 06 – Storage</i> <i>bit 07 – XML setup file</i> <i>bit 08 – RTC Battery</i> <i>bit 09 – Power Backup</i> <i>bit 10 – R01-R08 TWARN “Relay Over-Temp”</i> <i>bit 11 – R09-R16 TWARN “Relay Over-Temp”</i> <i>bit 12 – R01-R08 PGOOD “24V”</i> <i>bit 13 – R09-R16 PGOOD “24V”</i> <i>bit 14 – R01-R08 FAULT “Relay Fault”</i> <i>bit 15 – R09-R16 FAULT “Relay Fault”</i></p>
409052	Relay disabled due to temperature overload	bitmap	0x0000 – 0xFFFF	<p><i>0 = normal, 1 = disabled</i> <i>bit 00 – R1</i> <i>bit 01 – R2</i> <i>bit 02 – R3</i> ... <i>bit 15 – R16</i></p>
409053 to 409054	Carrier board temperature in milli-Celcius	32-bit integer	0 to 4,294,967,295	note: reg 409053 = high word (MSW first); Divide by 1000 to get the value in Celcius.
409061	Scale factor for registers 409062 – 409065	integer	1 or 1024	
409062 to 409063	Total memory, in bytes (MSW, LSW) (multiply by scale factor)	32-bit integer	0 to 4,294,967,295	note: reg 409062 = high word (MSW first);
409064 to 409065	Free space, in bytes (MSW, LSW) (multiply by scale factor)	32-bit integer	0 to 4,294,967,295	note: reg 409064 = high word (MSW first);
409101 to 409299	<i>reserved for factory use</i>			

3—ACCESSING THE SER EVENT LOG

Event Log Contents

The CyTime SER-32e features an event log file system containing up to 8192 event records. Each record consists of 8 registers (9 registers if reading all of the IO expansion card data) describing the event:

- date and time of the event (adjusted for local time, if applicable)
- input name
- event type
- input status
- time quality at time of the event
- unique record sequence number

File Record Access

The primary method for retrieving SER events is “file record access” using Modbus function code 20. The SER event log memory stores event records in “circular” fashion, rolling over after 8192 events, in a first-in-first-out (FIFO) stack. The total number of events is stored in holding register 402001, with record pointers in 402002 and 402003. First, these values are read (e.g., function code 03), then event records are accessed one at a time using function code 20, starting with the first event record position (from register 402002) through 8191, and starting over at 0, if necessary, up to the last event record position (stored in register 402003). To ensure reliable software access even after rollover (excess of 8192 events), the sequence number of last event record (registers 402004-402005) may be read periodically as well.

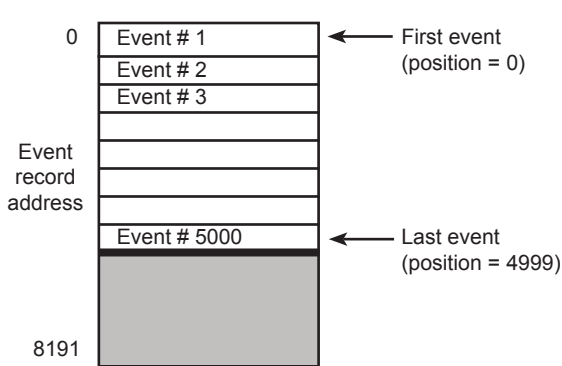

Example 1:
Total # of events = 5000

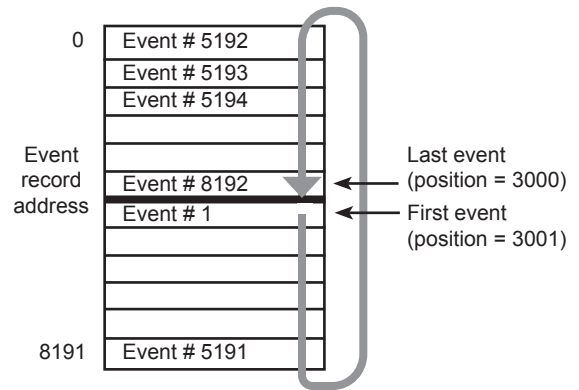

Example 2:
Total # of events = 8192

Table 3-1 – File Record Access (FC 20) Example

Description	Bytes	Request (hex)	Notes
Modbus Function Code 20	1 byte	0x14	function code 20 (hex 14) for file record access
Byte count	1 byte	0x07	always 0x07
Reference type	1 byte	0x06	always 0x06
File number	2 bytes	0x0001	always 0x0001
Record number	2 bytes	0x0000 to 0x1FFF	record position number of event to be read (based on value in register 402002: starting position)
Record length	2 bytes	0x0008 or 0x0009	8 or 9 (0x0008 or 0x0009), 9 registers if reading all of IO expansion card data.

Event Log Registers

Registers 402001 through 402005 are read using Modbus function code 03, while event records (8 registers per event record) are read using Modbus function code 20 for efficient file record access.

Table 3-2 – Event Log Registers

Register	Description	Type	Range	Notes
(ID = 1)	EVENT LOG REGISTERS			
402001	Number of events in event log	integer	1 to 8192	
402002	Position of first event record	integer	0 to 8191	
402003	Position of last event record	integer	0 to 8191	
402004 to 402005	Sequence number of last event record	32-bit int	0 to 4,294,967,295	note: reg 402004 = high word (big-endian—MSW first)
EVENT LOG FILE RECORD (TYPICAL FOR 8192)				
1	Event description, part 1	bitmap	0x0000 – 0xFFFF	bit 00 — bit 01 — bit 02 — bit 03 — bit 04 — bit 05 — bit 06 — bit 07 — bit 08 — bit 09 — bit 10 — bit 11 — bit 12 — bit 13 — bit 14 — bit 15 —
	Event description, part 2	bitmap	0x0000 – 0xFFFF	bit 00 — bit 01 — bit 02 — bit 03 — bit 04 — bit 05 — bit 06 — bit 07 — bit 08 — bit 09 — bit 10 — bit 11 — bit 12 — bit 13 — bit 14 — bit 15 —
3 and 4	No. of seconds since Jan 1, 1984 (LSW, MSW)	32-bit int	0 to 4,294,967,295	note: reg 3 = low word (little-endian—LSW first)
5 and 6	Event sequence number (LSW, MSW)	32-bit int	0 to 4,294,967,295	note: reg 5 = low word (little-endian—LSW first)
7 and 8	Coincident Status channels 1-32 ①	32-bit int	0 to 4,294,967,295	note: reg 7 - low word (little-endian - LSW first)

① Not applicable to system events. If reading 9 registers, 9 = Coincident Status 33-48

Record Sequence Numbers

Unique sequence numbers are assigned to each event record in the file, ranging from 0 to 4,294,967,295. Sequence numbers may be useful with application software to verify the sequence of event data uploaded over a period of time, even if the SER event record rolls over internally after its 8192 limit. In addition, if the event log is cleared, the unique sequence numbers distinguish new events from those previously recorded.

Event Codes

The event codes shown below are used in the event log file record to describe the type of event recorded by the SER.

Table 3-3 – Event Codes

Event Code	Type
0	Output Status Change (Off to On, On to Off)
1	Input Status Change (Off to On, On to Off)
2	Input (or Output) Enabled for Event Recording (by User)
3	Input (or Output) Disabled for Event Recording (by User)
4	Input Chatter Count Off (Event Recording Resumed)
5	Input Chatter Count On (Event Recording Suspended)
6	Power On
7	SER Inter-Device (RS-485) Time Sync Lock
8	SER Inter-Device (RS-485) Time Sync Fail
9	Internal Error
10	Event Log Cleared
11	24V Power Loss
12	24V Power Restored
13	<i>reserved</i>
14	Manual Time Set
15	Setup Configuration Changed
16	Daylight Saving Time (DST) Start/End Switchover
17	Reset
18	Firmware Upgraded
19	Power Fail
20	PTP / NTP Time Sync Lock
21	PTP / NTP Time Sync Fail
22	Time Sync Lock (IRIG-B or DCF77)
23	Time Sync Fail (IRIG-B or DCF77)
24	Test Mode ON
25	Test Mode OFF
26	High-Speed Trigger Out
27	Test Mode Input Status Change (Forced Off or On)
28	Test Mode Output Status Change (Forced OFF or ON)
29	RTC Battery Low
30	Power Control Module Issue
31	<i>reserved</i>

Type 2 Buffer (Compatibility Mode)

To maintain backwards compatibility with some legacy devices, the CyTime SER supports an additional method for retrieving event records. The table below shows the registers used (ID=1). The procedure is as follows:

1. Read coil (FC 01) at address 000001 until a "1" is returned.
2. Next, read holding register (FC 03) at address 400103 to get the total number of events in buffer (0 to 22).
3. Then read holding registers 400111 through 400198 (or fewer if buffer contains less than 22 events).
4. Once buffer contents read, write a "1" to coil at address 000002 (FC 05).
5. Begin reading coil 000001 again until value is set to "1"
6. Repeat process until all events are retrieved.

Note: with this method, only one master may retrieve event records, since the event log is cleared as events are read. This does not affect access to event log using File Record Access method (FC 20) described previously.

Table 3-4 – Compatibility Registers

Register	Description	Type	Range	Notes
(ID = 1)	COMPATIBILITY REGISTERS			
000001	Data buffer ready	bit (coil)	0 or 1	value of "1" indicates "ready"
000002	Data buffer acknowledge	bit (coil)	0 or 1	write "1" to clear buffer
400102	Buffer type	integer	2	
400103	Number of events in buffer	integer	0 to 22	
400111 to 400198	Event data (4 registers per event record)	bitmap, 32-bit int	---	see table with event log registers, reg 1 to 4

4—ACCESSING EPSS DATA LOGS

EPSS Data Log Overview

The CyTime SER-32e has 16 data log files each containing a variable number of event records. Each record consists of at least 5 registers describing the event, depending on the number of channels in the data log group:

- date and time of the event (adjusted for local time, 4 registers)
- input status at time of event (one register per group member)

Unlike the SER event log, the EPSS data logs record the details of an input whose status changes and *also* the status of all group members at the time of the event. This can be used by EPSS software to report the status change of one group member to trigger an event, such as an ATS switching to emergency power, while simultaneously reporting the condition of associated equipment in the emergency power supply system.

The data log structure for EPSS report data consists of up to 16 data log groups, each of which can be allocated a variable number of registers, up to a total of 56,000 for all log files. Data log file table of contents (TOC) are stored in fixed locations beginning with register number 402020. Each log file's TOC contains information describing the file's contents, including pointers to a header record at the beginning of each file which, in turn, contains the registers pointing to the status of group members. Refer to the diagram below for an explanation of this file structure.

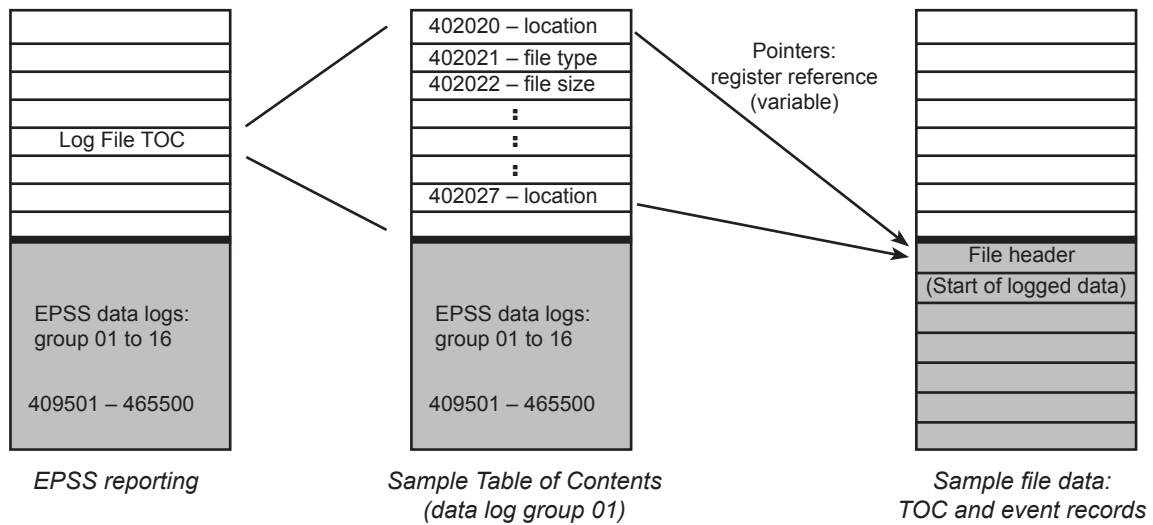

Fig 4–1. EPSS data file structure: overview

EPSS Data Log File Structure

The SER-32e EPSS data log structure is composed of variable-length records, depending on the number of channels assigned to a data log group. Each data file location (starting register number) is specified in the file’s “Table of Contents” (TOC). The first record in each EPSS data log file is a header record matching the register structure of all data records, but its values contain the channel number(s) whose status values are stored.

Legend
 Header = Header record which defines the contents of data records
 Record Length (RL) = 4 registers (for date/time) + 1 to 10 registers (1 per group member)
 Allocated File Size (AFS) = Total number of registers per log group allocated by user
 File Size (FS) = Actual number of registers used (equals “no. of records + 1” x RL)

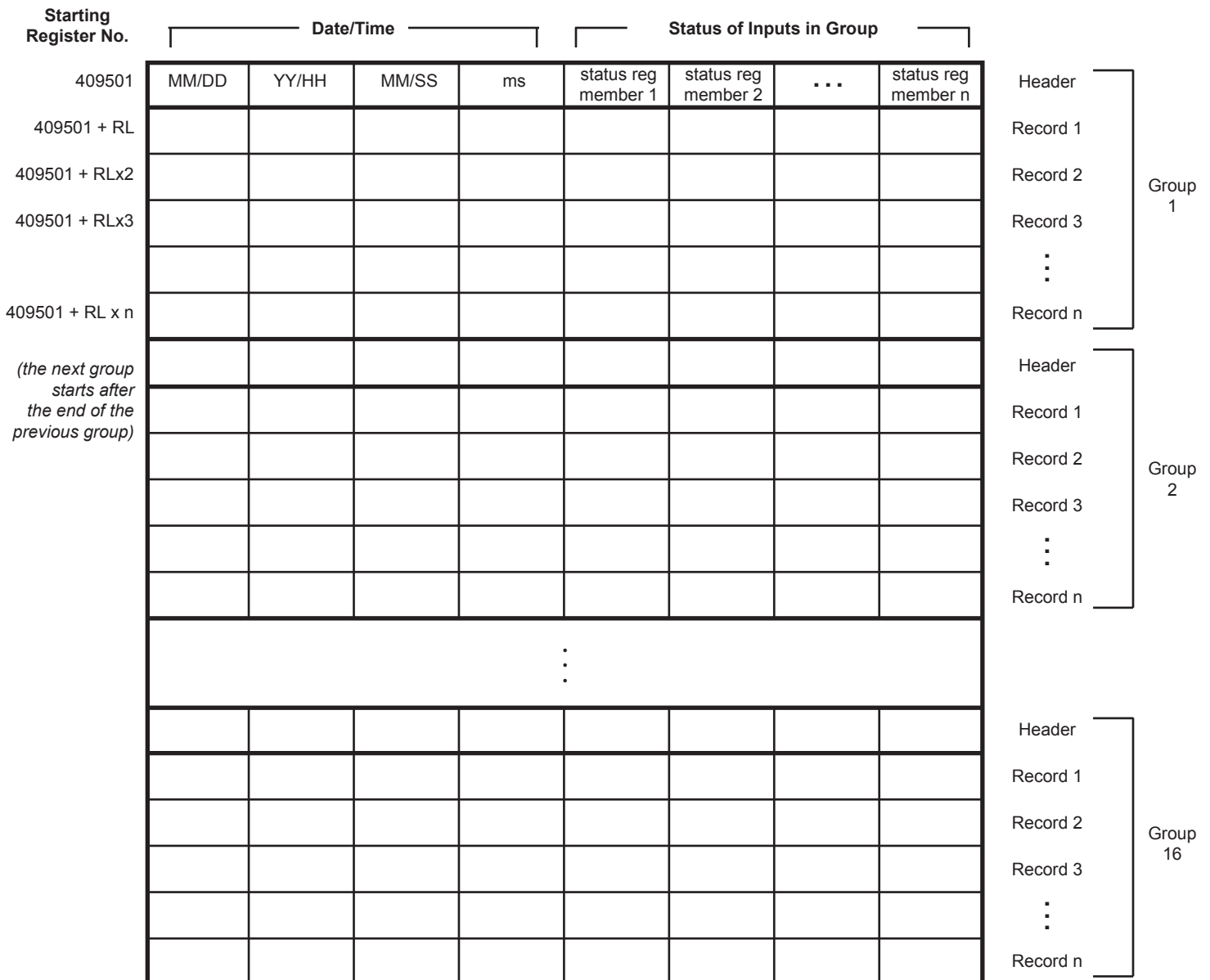

Fig 4–2. EPSS data log structure

5—COMMAND INTERFACE

Description

The CyTime SER-32e provides a command interface to support selected control actions over an Ethernet communications network using Modbus TCP. Single- or multiple-register writes are supported (Function Codes 06 or 16, respectively).

Table 5-1 – Command Interface Registers

Register	Description
(ID = 1)	COMMAND INTERFACE
408001	Command register (accepts command code)
408002 to 408016	Registers used to specify additional parameters, if applicable
408021 to 408150	Registers used for returned data, if applicable (reserved for future use)

Table 5-2 – Command Codes/Parameters

Command		Command Parameter		Description
REGISTER	CODE	REGISTER	PARAMETER(S)	
408001	1110	none	none	Causes soft reset of the unit (restarts device)
408001	4210	408002	1	Clears event log
408001	9700	none	none	Creates and activates default SSL certificate
408001	9750	408002	1	Recalibrates the HMI display
408001	21930	408002	24	Initiates auto-test (simulation): 1) generates a “Test Mode ON” event (code 24) in event log 2) generates a “Test Status Change” event, off-to-on and then back on-to-off, for each channel at 1 ms intervals. 3) generates a “Test Mode OFF” event (code 25) in event log indicating the end of test mode. (The device returns to normal mode and resumes event recording immediately after the test is completed.)
408001	25000	408002 and 408003	current date/time (local time) in sec. since Jan 1, 1984	Sets device clock to the specified date/time (big-endian): 1) place high word (MSW) in register 408002 2) and low word (LSW) in register 408003
408001	25001	408002 to 408005	current date/time	Uses condensed, 4-register format for date/time (includes ms)
408001	3365	408002	input number (1-32)	Reset operations counter for the specified input
408001	3365	408002	9999	Reset operations counters—all channels
408001	3320	408002	relay output number (1-16)	De-energize (turn off) the specified relay output R1-R16 for output expansion cards
408001	3321	408002	relay output number (1-16)	Energize (turn on) the specified relay output R1-R16 for output expansion cards
408001	3322	408002	16-bit bitmap corresponding to Relay outputs (R1-R16)	Control relay outputs—energize or de-energize the relay outputs, according to an 16-bit bitmap for output expansion cards. (allows simultaneous command of multiple relays using a single write).
408001	3361	408002	output number (1-16)	Reset operations counter for the specified output for output expansion cards
408001	3361	408002	9999	Reset operations counters—all outputs for output expansion cards.

Command Interface Example 1: Clear Event Log

Example: To clear the event log using the command interface:

1. Write value of 1 to parameter register 408002.
2. Write command code 4210 (0x1072) to command register 408001.
3. The SER clears the event log, records an “Event Log Cleared” event (code 10).

Note: The command interface registers can be written in one step using FC16 (multiple register write) or two steps using FC06 (single register write). If command is done in two steps, it must be done in the order shown above.

Command Interface Example 2: Initiate Auto Test

Example 2: To initiate auto-test using the command interface:

1. Write value of 24 to parameter register 408002.
2. Write command code 21930 (0x55AA) to command register 408001.
3. The SER enters test mode and generates “Test Status Change” events (code 27), off-to-on and on-to-off, for each input at 1 ms intervals, as well as test mode on/off events (codes 24 and 25).
4. Repeat process to initiate another test, if desired.

6—XML SETUP FILE

Setup File Overview

Note: the XML setup file should only be modified by advanced users familiar with XML structure, since errors could cause the SER to malfunction.

SER-32e setup data is stored in non-volatile memory in an XML file format. While the normal method for configuring the unit is through its embedded web pages, setup changes can also be made by editing the XML setup file using a text editor, such as Microsoft® Notepad. In the setup/admin section you can download the _SETUP.XML, modify it, and then upload it to the unit, or to a different unit. In this way, standard setup templates can be created and replicated quickly across multiple units.

XML Setup File Example

The XML setup file is called “_SETUP.XML”. An excerpt of the XML setup file is shown below.

```
<?xml version="1.0"?>
<setup xmlns:xsi="http://www.w3.org/2001/XMLSchema-instance" schemaVersion="8" xsi:noNameSpaceSchemaLocation="http://www.cyber-sciences.com/products/xsd/ser.xsd">
  <comms>
    <media_type>0</media_type>
    <DHCP_enabled>false</DHCP_enabled>
    <IP_address octet="1">169</IP_address>
    <IP_address octet="2">254</IP_address>
    <IP_address octet="3">0</IP_address>
    <IP_address octet="4">10</IP_address>
    <subnet_mask octet="1">255</subnet_mask>
    <subnet_mask octet="2">255</subnet_mask>
    <subnet_mask octet="3">0</subnet_mask>
    <subnet_mask octet="4">0</subnet_mask>
    <default_gateway octet="1">0</default_gateway>
    <default_gateway octet="2">0</default_gateway>
    <default_gateway octet="3">0</default_gateway>
    <default_gateway octet="4">0</default_gateway>
    <FTP_enabled>false</FTP_enabled>
    <device_ID>SER-32e</device_ID>
    <device_name>SER-32e</device_name>
    <Modbus_enabled>true</Modbus_enabled>
  </comms>
  <time>
    <time_source>4</time_source>
    <time_sync_master>false</time_sync_master>
    <time_sync_out>2</time_sync_out>
    <time_zone_offset>-6.00</time_zone_offset>
    <time_zone_offset_PLX>false</time_zone_offset_PLX>
    <time_zone_offset_ASCII>false</time_zone_offset_ASCII>
    <DST_enabled>false</DST_enabled>
    <DST_start>
      <month>3</month>
      <week>2</week>
      <day>1</day>
      <hour>2</hour>
    </DST_start>
    <DST_end>
      <month>11</month>
      <week>1</week>
      <day>1</day>
      <hour>2</hour>
    </DST_end>
    <alt_date_format>false</alt_date_format>
    <hourly_time_update>false</hourly_time_update>
  </time>
</setup>
```



```

<NTP_interval>60</NTP_interval>
<NTP_server1 octet="1">24</NTP_server1>
<NTP_server1 octet="2">56</NTP_server1>
<NTP_server1 octet="3">178</NTP_server1>
<NTP_server1 octet="4">140</NTP_server1>
<NTP_server2 octet="1">129</NTP_server2>
<NTP_server2 octet="2">6</NTP_server2>
<NTP_server2 octet="3">15</NTP_server2>
<NTP_server2 octet="4">29</NTP_server2>
<PTP_domain_number>0</PTP_domain_number>
<PTP_priority1>128</PTP_priority1>
<PTP_priority2>128</PTP_priority2>
</time>
<inputs>
<input id="1">
  <enabled>true</enabled>
  <input_name>Input 01</input_name>
  <filter>0</filter>
  <debounce>0</debounce>
  <chatter>0</chatter>
  <off_text>Off</off_text>
  <on_text>On</on_text>
  <trigger>>false</trigger>
  <inverted>>false</inverted>
  <log_group>0</log_group>
</input>
  .
  .
  .
<outputs>
  <output id="1">
    <enabled>true</enabled>
    <output_name>Output 01</output_name>
    <off_text>Off</off_text>
    <on_text>On</on_text>
    <log_group>0</log_group>
  </output>
  .
  .
  .
</outputs>
<groups>
  <group id="1">
    <enabled>>false</enabled>
    <group_name>Group 01</group_name>
    <log_size>0</log_size>
  </group>
  .
  .
  .
</groups>
<admin>
  <username>admin</username>
  <password>***** =</password>
</admin>
</setup>

```

Fig 6–2. XML setup file (_SETUP.XML)

7—RESTFUL API

Overview

The SER-32e provides access to status, event, setup and diagnostic information through its secure (HTTPS) web interface. The HTML5 web interface is based on a “REST-ful” design (Representational State Transfer). It implements client-side open standards such as HTML5, JQuery, JQuery UI, Bootstrap, JSON, CSS3, JavaScript, & AJAX. The web interface uses REST-based operations (HTTP GET & HTTP POST) via AJAX (Active JavaScript) to get or post static and dynamic data. The API returns JSON data (JavaScript Object Notation) for both the HTTP GET & HTTP POST requests.

Information on implementing typical HTTP GET requests is included here. For additional detail and information on all HTTP GET and HTTP POST requests, refer to “SER-32e_REST_Web_Service_API_HTML5.pdf”.

HTTP GET - Supported Commands

- 1) `"/setup/comms"`
- 2) `"/setup/time"`
- 3) `"/setup/time/refresh"`
- 4) `"/setup/inputs"`
- 5) `"/setup/outputs"`
- 6) `"/setup/groups"`
- 7) `"/setup/groups/name"`
- 8) `"/setup/admin"`
- 9) `"/setup/https"`
- 10) `"/setup/configuration"`
- 11) `"/setup/firmware_upgrade"`
- 12) `"/channels/status"`
- 13) `"/channels/data"`
- 14) `"/channels/name"`
- 15) `"/channels/name/ext"`
- 16) `"/events/last"`
- 17) `"/events" (top 100)`
- 18) `"/events?record=0&count=10" (query based)`
- 19) `"/events/short" (plus record/count query)`
- 20) `"/events/verbose" (plus record/count query, max 50 records)`
- 21) `"/events/posix" (plus record/count query)`
- 22) `"/events/posix/short" (plus record/count query)`
- 23) `"/events/posix/verbose" (plus record/count query, max 50 records)`
- 24) `"/diag"`
- 25) `"/diag/refresh"`
- 26) `"/diag/backups"`
- 27) `"/modbus?register=201&count=10"`

HTTP GET - Command Descriptions

The response values for each HTTP GET request are described below. Response strings are in JSON format, i.e. {"key1": "value1", "key2": "value2"}.

"/channels/status"

This reports the channels' current states and other setup data.

- 1) Response parameters
 - a) Status
This is a bitmask with left most bit channel 1, right most bit channel 32. A bit value of 1 indicates the channel is in on.
 - b) Inverted
A bitmask indicating each channel's inverted setting. Left most bit is channel 1.
 - c) Forced_off / Forced_on
A bitmask indicating each channel's forced off/on state (which only occurs during test mode). Left most bit is channel 1.
- 2) Example response:
{ "status": 8, "inverted": 8, "forced_off": 0, "forced_on": 0, "device_diagnostics": 0 }

"/events/last"

This reports the event record pointers.

- 1) Response parameters
 - a) NumberOfEvents
This is the total number of events captured, from 1 to 8192.
 - b) FirstRecord
This is the location from 0 to 8191 of the first record location.
 - c) LastRecord
This is the location from 0 to 8191 of the last record location.
 - d) LastSequenceNumber
This is the sequence number of the last record.
- 2) Example response
{ "NumberOfEvents": 8192, "FirstRecord": 0, "LastRecord": 10, "LastSequenceNumber": 10340819 }

"/events" (top 100, 8 register format with local 1984 epoch timestamp)

- 1) Example response:
{ "events": [{"r": "0221-828A-C46B-3FD5-0001-0000-0000-0000"}, {"r": "021A-838A-C46E-3FD5-0064-0000-0000-0000"}] }

*See page 21, "Table 3-2 – Event Log Registers" for format.

"/events?record=0&count=3" (8 register format with local 1984 epoch timestamp)

- 1) Example response:
{ "events": [{"r": "0641-8013-C420-3FD5-0001-0000-0000-0000"}, {"r": "0261-8013-C420-3FD5-0002-0000-0000-0000"}, {"r": "021A-810D-C420-3FD5-0003-0000-0000-0000"}] }

*See page 21, "Table 3-2 – Event Log Registers" for format.

"/events/short?record=0&count=3" (4 register format with local 1984 epoch timestamp)

- 1) Example response:
{
 "events": [{"r": "0641-8013-C420-3FD5"}, {"r": "0261-8013-C420-3FD5"}, {"r": "021A-810D-C420-3FD5"}]}
}

*See page 21, "Table 3-2 – Event Log Registers" for format.

"/events/verbose?record=0&count=3" (with local 1984 epoch timestamp, 50 records max)

- 1) Example response:
{
 "events": [{"event_type": 10, "channel": 0, "status": 0, "dst_active": 1, "milliseconds": 725, "time_quality": 0, "seconds": 1176554005, "seq_num": 1, "coincident": 0}, {"event_type": 19, "channel": 0, "status": 0, "dst_active": 1, "milliseconds": 761, "time_quality": 0, "seconds": 1176554941, "seq_num": 2, "coincident": 0}, {"event_type": 6, "channel": 0, "status": 1, "dst_active": 1, "milliseconds": 2, "time_quality": 3, "seconds": 1176554983, "seq_num": 3, "coincident": 0}]}
}

*See page 21, "Table 3-2 – Event Log Registers" for format.

"/events/posix?record=0&count=3" (8-register format with Posix epoch UTC timestamp)

- 1) Example response:
{
 "events": [{"r": "0641-8013-3AF9-6075-0001-0000-0000-0000"}, {"r": "0261-8013-3EA1-6075-0002-0000-0000-0000"}, {"r": "021A-810D-3ECB-6075-0003-0000-0000-0000"}]}
}

*See page 21, "Table 3-2 – Event Log Registers" for format.

"/events/posix/short?record=0&count=3" (4-register format with Posix epoch UTC timestamp)

- 1) Example response:
{
 "events": [{"r": "000A-02D5-3AF9-6075"}, {"r": "0013-02F9-3EA1-6075"}, {"r": "0406-C002-3ECB-6075"}]}
}

*See page 21, "Table 3-2 – Event Log Registers" for format.

"/events/posix/verbose?record=0&count=3" (with Posix epoch UTC timestamp, 50 records max)

- 1) Example response:
{
 "events": [{"event_type": 10, "channel": 0, "status": 0, "dst_active": 0, "milliseconds": 725, "time_quality": 0, "seconds": 1618295545, "seq_num": 1, "coincident": 0}, {"event_type": 19, "channel": 0, "status": 0, "dst_active": 0, "milliseconds": 761, "time_quality": 0, "seconds": 1618296481, "seq_num": 2, "coincident": 0}, {"event_type": 6, "channel": 0, "status": 1, "dst_active": 0, "milliseconds": 2, "time_quality": 3, "seconds": 1618296523, "seq_num": 3, "coincident": 0}]}
}

*See page 21, "Table 3-2 – Event Log Registers" for format.

HTTP GET - Example Use

The following examples demonstrate how to access Status and Event data from the SER.

How to get status

To get Status information, use the following HTTP Get command **"/channels/status"**. Simply navigate to the SER's IP address, log-in and append the command to the IP address, i.e.: <https://169.254.0.10/channels/status>

This example JSON data is object for status information identifying Input 4 = ON and Inverted: `{"status": 8,"inverted": 8,"forced_off": 0,"forced_on": 0,"device_diagnostics": 0}`

Status JSON Format

Each value in the keys of this JSON object is an unsigned 32-bit integer decimal value where a value of 0 = OFF and a value of 1 = ON. Input channels are represented in the JSON object as:

- bit 00 – Input 1
- bit 01 – Input 2
- bit 02 – Input 3, etc.

- 1) "status" - Status of channels.
- 2) "inverted" - Inversion of Inputs.
- 3) "forced_off" - Test Mode Input Status (Forced OFF).
- 4) "forced_on" - Test Mode Input Status (Forced ON).
- 5) "device_diagnostics" - Device diagnostics, self-test results.

*See Page 19, Modbus registers 9051 – 9052 for diagnostics format.

How To Get Events

To get Event log records, use the following two HTTP Get commands: `"/events/last"` and `"/events"`. First, use the `"/events/last"` to discover the number of events in the Event log. From this result, the `"/events"` command can be called with the parameters for starting record and number of records desired. Here are examples for each:

To get the number of events in the Event log, use the command: `"/events/last"`. This command returns a JSON object:

```
{"NumberOfEvents": 8192, "FirstRecord": 0, "LastRecord": 8191, "LastSequenceNumber": 10340819}
```

From this result, the top 100 events in the log can be requested by subtracting (100-1) from "LastRecord" as the "record" parameter, and enter 100 as the "count" parameter:

```
"/events?record=8092&count=100"
```

NOTE: The maximum number of events that can be requested by one call is 100.

The command `"/events?record=8092&count=100"` returns a JSON object:

```
{"events": [{"r": "0814-0141-38E4-4085-1F9D-0000-0000-0000"}, xxx, {"r": "0814-0174-6F5A-4092-2000-0000-0000-0000"}]} (only the first record and last record are shown)
```

Events JSON Format

`"/events/last"`

- 1) NumberOfEvents - number of events in event log.
- 2) FirstRecord – The zero based starting record position of the request.
- 3) Count – The total number of records requested.
- 4) LastSequenceNumber - sequence number of last event record.

“/events?record=8092&count=100” – this command uses parameters for record and count, where “?” precedes the first event record number, and “&” precedes the count parameter.

Each Event log record contains the registers for:

- 1) Event record description.
- 2) Number of seconds.
- 3) Last sequence number.
- 4) Bit mask of coincident input status.

For the example, the first register’s value is “0814-0141-38E4-4085-1F9D-0000-0000-0000”. This is the event record for event 8092. The event record is eight 16-bit hex values (registers 1-8), separated by the dash symbol. To parse the event record, split the result into an array, separated by the “-”(dash) symbol.

- 1) “0814” hex value is the event description part 1 (reg 1).
- 2) “0141” hex value is the event description part 2 (reg 2).
- 3) “38E4” (reg 3) and “4085” (reg 4) hex value is the number of seconds since Jan 1, 1984 in local time. (LSW, MSW), where “38E4” (reg 3) = low word (little-endian—LSW first).
- 4) “1F9D” (reg 5) and “0000” (reg 6) hex value is the sequence number of the event record (LSW, MSW), where “1F9D” (reg 5) = low word (little-endian—LSW first).
- 5) “0000” (reg 7) and “0000” (reg 8) hex value are the coincidence channels (MSW, LSW), where “0000” (reg 7) = high word (big-endian—MSW first).

*Please see Page 21, Table 3-2 – Event Log Registers for format.

8—PRECISION TIME PROTOCOL (PTP)

Precision Time Protocol (per IEEE 1588)

1588 Time Settings Convention:

The IEEE 1588 standard expresses Announce, Sync and Delay message interval settings as a log-base2 of the value in seconds (2^{-128} to 2^{127}), subject to further limits established in a PTP profile.

For example, a setting of “0” = 2^0 (1 second). See the conversion table below for some common values.

Interval Setting (Log-Base2 Result)	Interval Value (Seconds)
-1	0.5
0	1
1	2
2	4
3	8
4	16
5	32

To avoid confusion, Cyber Sciences expresses all time intervals in seconds, except for Modbus register values (which require a signed-integer format). When comparing with third-party PTP settings, be careful to note the convention used.

Introduction to IEEE 1588-2019

IEEE Std 1588 defines the Precision Time Protocol (PTP) with a goal of achieving very high precision for time-synchronization over a packet-based network such as Ethernet. PTP takes advantage of special Ethernet hardware for precise time-stamping of the Ethernet frame send and receive times and prescribes a very precise mechanism to correct for delays introduced in the network path from the master clock (time reference), through multiple levels of switches, to the slave clocks (time consumers).

The Simple PTP Profile—Based on IEEE 1588 Default Profile

CyTime SER-32e Event Recorders use a “Simple PTP” Profile optimized for commercial/industrial power system applications (including data centers, hospitals and microgrids). Simple PTP is intended to achieve time sync over Ethernet with accuracy of at least 100 μ s, taking advantage of the same Ethernet network infrastructure used for power monitoring—without requiring special PTP-compliant Ethernet switches (transparent clocks). There is no need for special prioritization of PTP packets in managed switches, nor any constraints on network topology. To accomplish time synchronization, Simple PTP uses the PTP delay request-response mechanism (also called “End-to-End”). Other simplifications include using UTC as its timescale (instead of TAI) and longer message intervals (e.g., updates every 32s) to minimize network traffic.

PTP Options Supported by CyTime SER-32e

Though the “Simple PTP” Profile is proposed by Cyber Sciences, it is not proprietary. Simple PTP is based on the IEEE 1588 “Default Profile” defined in (IEEE-1588-2008 Annex J and 2019 Annex I). Devices using Simple PTP are interoperable with others set to use this profile.

When SER-32e Event Recorders are used as both the PTP master and PTP slaves, they support the PTP options indicated below. When a third-party clock is used as grandmaster, the SER-32e PTP slaves can support the options shown in the column at right. In general, set third-party clocks to use the Default Profile (Delay Request-Response, or E2E) for compatibility with the SER-32e.

PTP Options	Range of Supported Values	
	SER Master and Slave	SER Slave-only (compatibility)
PTP Version Number (IEEE 1588)	v2 (2008) / v2.1 (2019)	v2 (2008), v2.1 (2019)
PTP Profile ID (IEEE 1588 Default Profile, Annex I - 2019 / Annex J - 2008)	00-1B-19-00-01-00	00-1B-19-00-01-00
Clock Types Supported	Ordinary clock: Grandmaster-capable Slave-only	Ordinary clock: Slave-only
Communications Model	Multicast	Multicast
Network Transport Protocol	UDP/IPv4	UDP/IPv4
Path Delay Mechanism	End-to-end (E2E)	End-to-end (E2E)
Operating Mode	2-step	1-step or 2-step
Timescale	Application-specific (UTC)	Application-specific (UTC) or PTP (TAI)

PTP Settings and Attributes Supported

When SER-32e Event Recorders are used as both the PTP master and PTP slaves, they support the simplified PTP settings and attributes indicated below. For compatibility with a third-party clock used as grandmaster, SER-32e PTP slaves can support a wider range of settings and attributes, as shown on right.

PTP Settings and Attributes	Range of Values Supported	
	SER Master and Slave	SER Slave-only (compatibility)
Domain Number	0 to 127 (default = 0)	0 to 127 (default = 0)
Announce Interval (master)	2 seconds	1, 2, 4, 8, 16, 32 sec
Announce Receipt Time-out (master)	3 (Multiple of Announce Interval)	2 to 10 (Multiple of Announce Interval)
Sync Interval (master)	1 second	0.5, 1, 2, 4, 8, 16, 32, 64 sec
Delay Request Interval (master)	32 seconds	0.5, 1, 2, 4, 8, 16, 32, 64 sec (1588 std requires Delay Request Interval to be >= the Sync Interval and <= 32x)
Priority1 and Priority2	0-255 (master), 255 (slave)	255 (slave)
Clock Identity	(Usually based in part on MAC address)	(Usually based in part on MAC address)
Port State	1 = Initializing (transient state) 2 = Faulty (error condition) 3 = Disabled (PTP not used) 4 = Listening (waiting for sync) 5 = Pre-master (transient state) 6 = Master (normal state for PTP master) 7 = Passive (only for multiple masters) 8 = Uncalibrated (transient state) 9 = Slave (normal state for PTP slave)	1 = Initializing (transient state) 2 = Faulty (error condition) 3 = Disabled (PTP not used) 4 = Listening (waiting for sync) 5 = Pre-master (not applicable) 6 = Master (not applicable) 7 = Passive (not applicable) 8 = Uncalibrated (transient state) 9 = Slave (normal state for PTP slave)
Clock Class	13 = Normal (UTC) 14 = Holdover (UTC) 58 = Out-of-spec (UTC) 255 = Slave-only	06 = Normal (PTP Timescale) 07 = Holdover (PTP Timescale) 13 = Normal (UTC) 14 = Holdover (UTC) 52 = Out-of-spec (PTP Timescale) 58 = Out-of-spec (UTC) 255 = Slave-only
Clock Source *	16 (0x10) = Atomic clock 32 (0x20) = GPS 64 (0x40) = PTP 80 (0x50) = NTP 96 (0x60) = Hand-set (manual) 144 (0x90) = Other 160 (0xA0) = Internal (none)	16 (0x10) = Atomic clock 32 (0x20) = GPS 64 (0x40) = PTP 80 (0x50) = NTP 96 (0x60) = Hand-set (manual) 144 (0x90) = Other 160 (0xA0) = Internal (none)
Clock Accuracy *	39 (0x27) = 100 μs 41 (0x29) = 1 ms 43 (0x2B) = 10 ms 45 (0x2D) = 100 ms 47 (0x2F) = 1 s 49 (0x31) = >10s 254 (0xFE) = unknown	32 (0x20) = 25 ns 33 (0x21) = 100 ns 39 (0x27) = 100 μs 41 (0x29) = 1 ms 43 (0x2B) = 10 ms 45 (0x2D) = 100 ms 47 (0x2F) = 1 s 49 (0x31) = >10s 254 (0xFE) = unknown
PTP Packet Time-To-Live (TTL)	64	1 to 64

* for PTP slaves, this value is obtained from the PTP grandmaster.

Timescales and Leap Seconds

Relationships of Timescales

GPS = Global Positioning System
TAI = International Atomic Time
UTC = Coordinated Universal Time

TAI is always ahead of GPS time by 19 seconds. At the time of this publication, there have been 36 leap seconds. This gives the following relationships:

TAI = GPS + 19 s
UTC = GPS - 17 s (and counting)
UTC = TAI - 36 s (and counting)

There are three different timescales used for time synchronization: UTC, TAI and GPS. UTC is adjusted periodically for changes in the rate of the earth’s rotation by adding or subtracting leap seconds, whereas, TAI and GPS are not affected. PTP specifies TAI as its default timescale. Today, the use of TAI vs. UTC is somewhat academic; most devices use UTC as their time reference but ignore any advance warning of “leap second coming” even if present, such as the announce bit in the IRIG-B standard. Furthermore, it’s not clear how they would use this information even if they did support it. There have been several instances of leap seconds in the past 20 years, the most recent in 2016. Timestamps of events recorded just before or just after the leap second may produce confusing data, but otherwise, devices are expected to operate normally without incident.

The PTP standard also allows for other timescales (primarily UTC), but these are designated by alternate attribute codes. Any timescale other than TAI is called “Arbitrary” (or “ARB”) or “application specific.”

Please refer to the summary chart at left for a comparison of the three timescales, as well as their relationship to each other.

Adjusting for Local Time Zone

Historical events are stored with date/timestamps relative to a known time reference, such as UTC (Coordinated Universal Time). There are two accepted methods for adjusting timestamps for a local time zone: adjust once at the final point of consumption (Figure 8-1), or set each intermediate device to use the appropriate time zone offset, but still transfer the time reference to each via UTC (Figure 8-2).

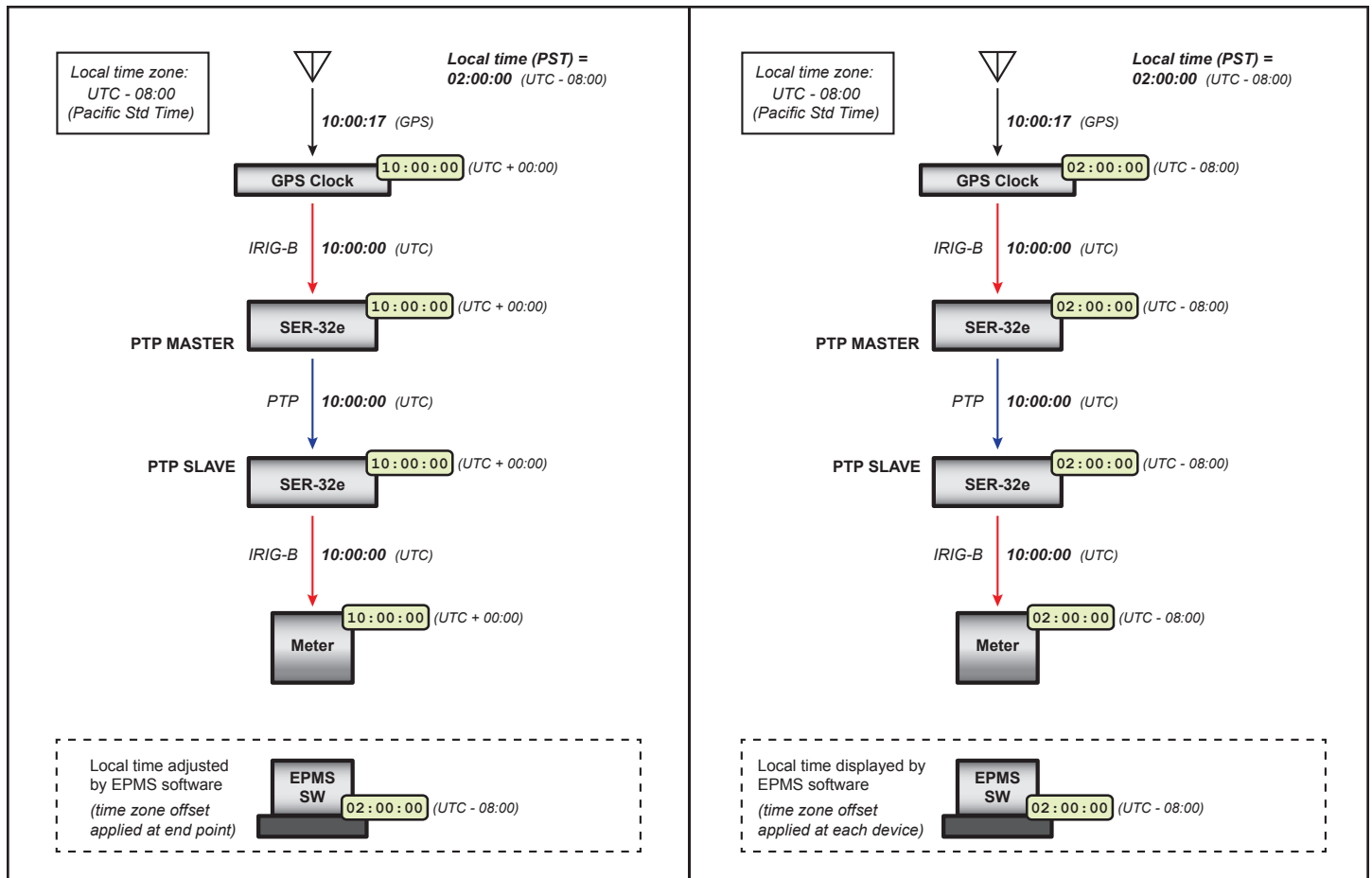

Figure 8-1. Local time adjusted at end-use point (EPMS software)

Figure 8-2. Local time adjusted at each device in system

Adjusting for Local Time Zone (cont.)

The example in Fig 8-1 is attractive for its simplicity, and the example in Fig 8-2 is sometimes considered more intuitive. However, this second option requires that all devices be equipped with a local time zone setting, which is not always the case. Consider the example in Fig 8-3. Without some way to adjust the time reference in the DCF77 signal to the meter it will simply display the time as received (UTC).

To solve this interoperability problem, the CyTime SER-32e offers a setup option to “apply local time zone offset” to one or more of its output signals (IRIG-B or DCF77 via PLX accessory or ASCII/RS-485 output native to the SER). Fig. 8-4 illustrates the solution employing this method. Instead of transferring the time reference based on UTC between devices, the SER outputs the time reference in DCF77 already adjusted for the local time zone.

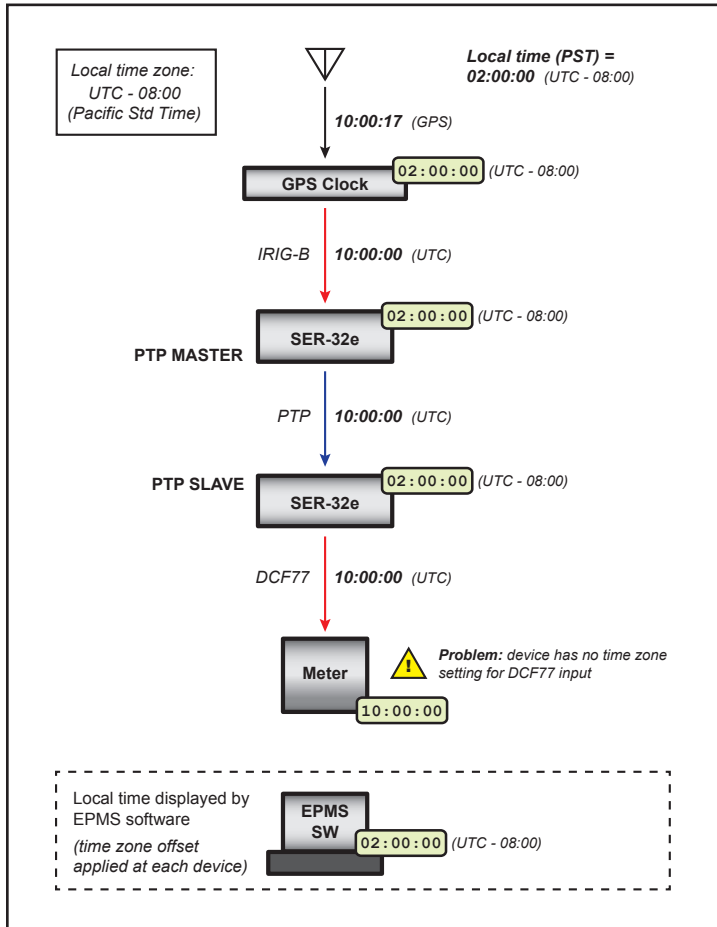

Figure 8-3. Local time adjusted at each device—except one

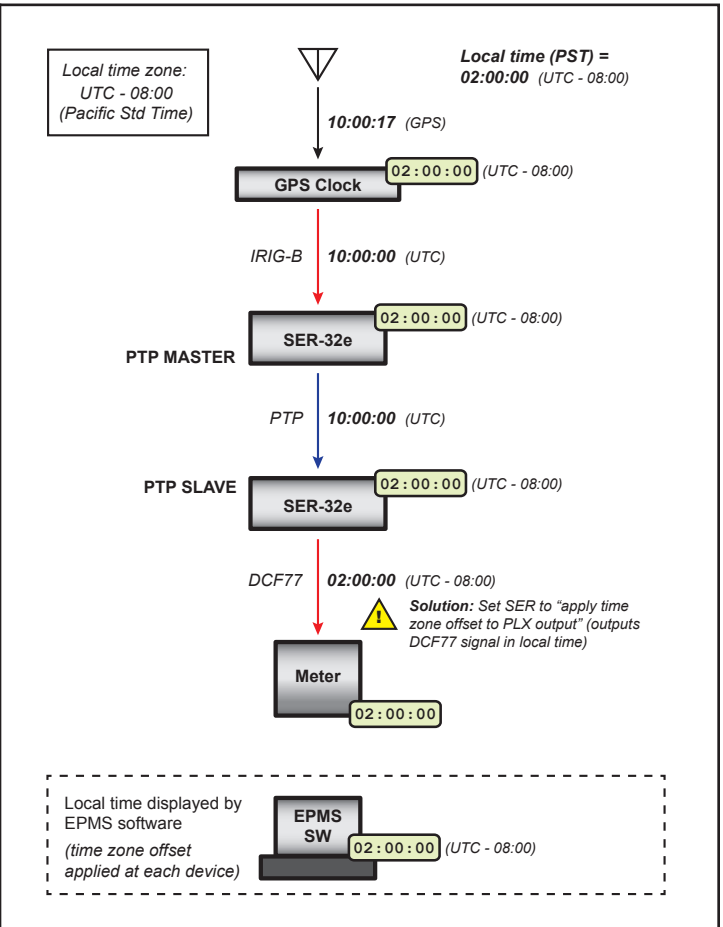

Figure 8-4. Local time adjusted at (or to) each device

Adjusting for Local Time Zone (cont.)

One final example of adjusting clocks for local time zone offset is shown in Fig. 8-5 below. In this example, a third-party GPS clock is configured as PTP master, and transmits its time reference in terms of TAI. PTP slave devices such as the CyTime SER automatically adjust from TAI timescale to UTC timescale. Then, if desired, each device adjusts its own clock for the local time zone according to its user setting.

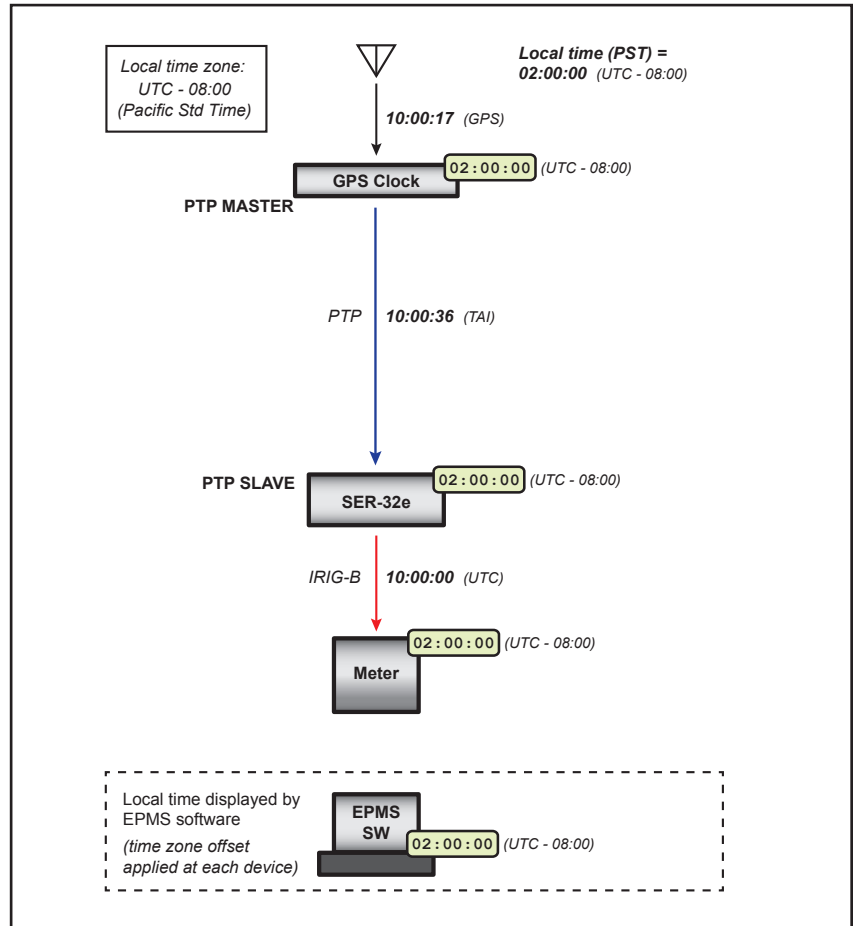

Figure 8-5. Local time adjusted at each device in system (GPS clock as PTP master)

Daylight Saving Time (DST)

Cyber Sciences recommends that event timestamps be based exclusively on UTC or standard time, since discontinuities introduce potential for confusion and make comparisons of historical values more difficult. For example, if events occur around the time of the start of DST (“Spring forward”), their timestamps may appear one hour further apart than the actual elapsed time.

Even worse, events recorded during the ending changeover (“Fall back”), can have the same timestamps as events actually occurring one hour apart, with no way to distinguish the truth. Clearly, the concept of Daylight Saving Time is not compatible with timestamps in sequence of events recording.

To provide maximum flexibility, the CyTime SER supports adjustments for Daylight Saving Time (DST) or Summer Time. However, it is recommended all event timestamps be stored in reference to UTC and adjusted for local time and DST by application software at the point of consumption (edge software application) to enable system wide display, analysis and analytics.

9—TROUBLESHOOTING

LCD Error Messages	Possible Cause	Suggested Actions
1000	Internal firmware update error	Restart the unit ①, verify firmware revisions are as expected. Run, or re-run latest firmware update. If problem repeats, contact technical support
2000	Internal error	Restart the unit ①, if issue returns contact technical support
3000	XML setup error	Restart the unit ①, if issue returns contact technical support
6000	Error on initialization	Restart the unit ①, if issue returns contact technical support
7000	Read error	Restart the unit ①, if issue returns contact technical support
8000	Write error	Restart the unit ①, if issue returns contact technical support
65535	All other errors	Restart the unit ①, if issue returns contact technical support
Error	Possible Cause	Suggested Actions
No PTP Time Sync	PTP master clock may need configuration, has lost its time sync, or the PTP master clock is set to a different domain.	<ul style="list-style-type: none"> • Check that the master clock is time synced and set the slave devices to the same domain number • Ensure the PTP master clock is configured for the Delay Request-Response Default PTP profile • Confirm managed Ethernet switch(s) are configured to support PTP messaging • Ensure there is not another PTP master in the system with same domain number • - Ensure all managed switches are configured to allow PTP packets
Loss of Time Sync (PTP)	PTP master clock has lost its time sync or has been set to a different domain number.	<ul style="list-style-type: none"> • Confirm the PTP master clock is time sync'ed • Ensure the PTP master and slave devices have the same domain number
Loss of Time Sync (NTP)	NTP servers are invalid or unreachable, or the NTP clock has lost its time sync.	<ul style="list-style-type: none"> • Check the "Last Successful NTP Sync" value on the SER's Time setup web page. A value of '---' indicates the NTP server is unreachable • Ensure the Subnet mask and default gateway are correct in Setup>> Communications • Confirm network connectivity to the NTP server • Ensure the NTP clock is synchronized • Enter an alternate NTP server IP address. • Restart the SER
Events are Out of Order	<p>A channel could be configured with a longer filter and/or debounce setting than the other channels resulting in additional time being required to confirm a valid event.</p> <p>The time value on an event appears far off.</p>	<ul style="list-style-type: none"> • This is normal behavior if the filter and/or debounce values are significantly different between channels. To correct the view, click on the "Date/Time" heading in the "Monitoring/Events" web page to sort events by date/time • Refresh the web page view by pressing F5 • This could happen if events occur while the unit is acquiring its time sync lock. Sort events by sequence number instead of date/time

Error	Possible Cause	Suggested Actions
Event With 'Internal Error' Description Appears	An event record has been corrupted.	<ul style="list-style-type: none"> • A backup of the event file may be retrieved for further examination. Contact technical support for assistance.
Web Interface Appears Unavailable	<p>Incorrect URL in the address bar.</p> <p>The IP address is unreachable from the browser's location on the network, or another device is using the same IP address as the SER.</p>	<ul style="list-style-type: none"> • Verify the SER's IP address by viewing the Communications (third) tab on the LCD. • Verify the IP address can be pinged and that there is no other device on the network that shares the same IP address. • If another device is using the same IP address, one of the device's IP addresses must be changed.
Unable to Access the Modbus Registers	<p>The SER provides an option to enable or disable Modbus communications on the "Setup > Communications" web page.</p> <p>Port 502 is blocked on your network.</p>	<ul style="list-style-type: none"> • Confirm the " Modbus Server Enabled" option is selected and click apply. • Enable port 502 on managed IT devices.
Inputs Do Not Work	24 Vdc whetting voltage may not be present.	<ul style="list-style-type: none"> • Ensure 24 Vdc whetting voltage is present on contacts being monitored. • Confirm Input voltages are within SER specification (24 Vdc, -15% / +10%). Input voltages outside this range may not function as expected or may damage inputs.
Lost / Forgotten User Login Credentials	Personnel change or typing error in entering login credentials.	<ul style="list-style-type: none"> • The SER provides a method for resetting login credentials to factory defaults. Refer to "Section-4" of the SER User's Guide (IB-SER-04) for detailed instructions.

① Restart device through the device's display or web page, pressing the reset button, or by disconnecting from power, then reconnecting again.

Technical Support

If you have questions we recommend reviewing the Technical Library and FAQs on our web site, or request technical support through our our website at: www.cyber-sciences.com/our-support/support-contact or call 615-890-6709.

Prior to contacting Cyber Sciences' technical support, please be prepared to provide:

- Model number
- Serial number
- MAC address
- Firmware version
- Hardware version
- Date of manufacturer

This information can be found on the device's product label, display under "Diagnostics" (second tab from the right) or web page under "Diagnostics>Device".

Providing a detailed description of the issue (screen captures, event logs, information from 'Diagnostics') can be very helpful.

The service marks, "Reliable Power Starts With Reliable Data," CyTime, and the Cyber Sciences stylized logo are trademarks of Cyber Sciences.
All other trademarks are the property of their respective owners.



Cyber Sciences, Inc. (CSI)
229 Castlewood Drive, Suite E
Murfreesboro, TN 37129 USA
Tel: +1 615-890-6709
Fax: +1 615-439-1651



Doc. no: IB-SER32e-02 December 2024
(Supercedes Jan-2022)