

FRONT VIEW

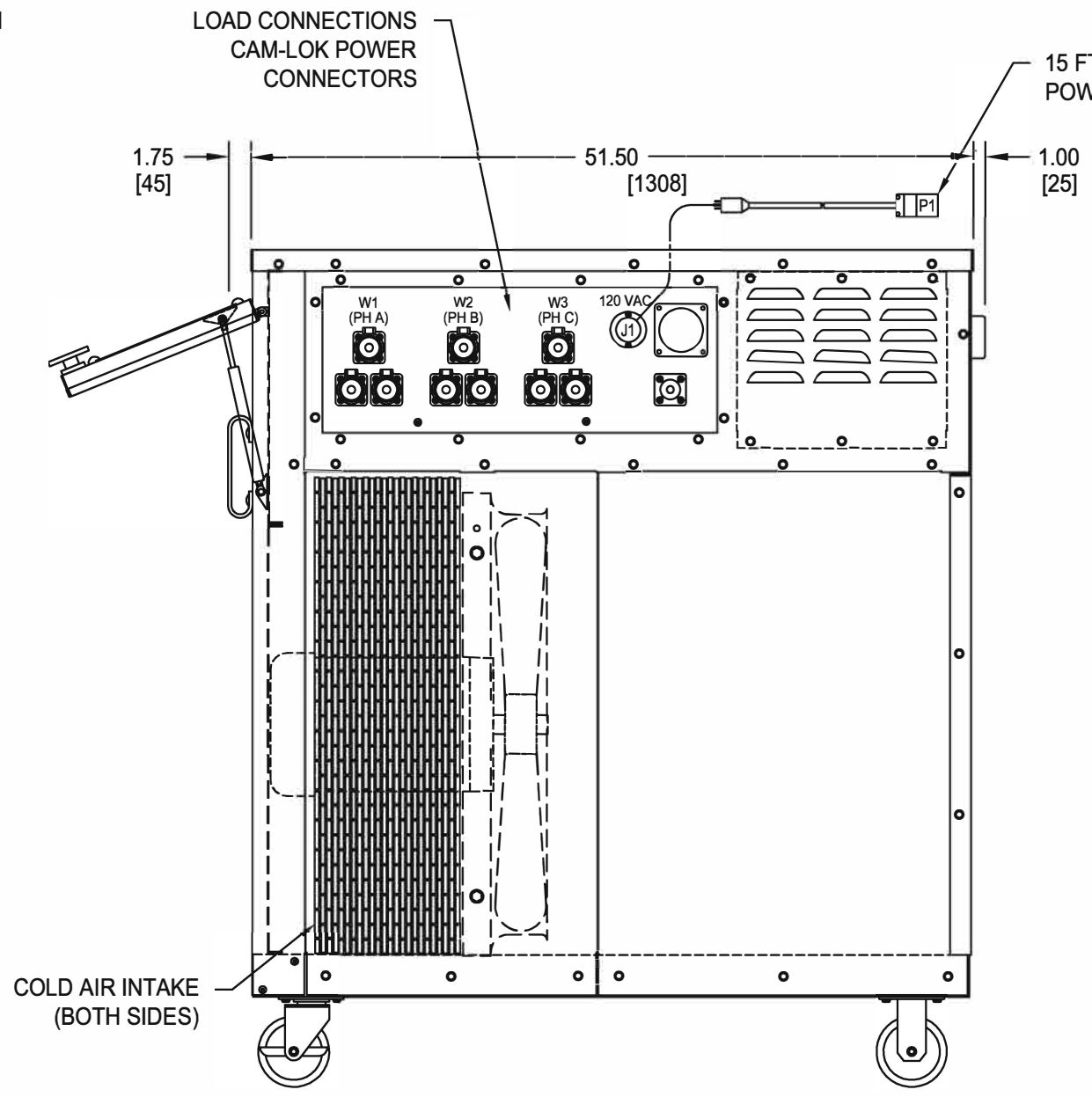

RIGHT SIDE VIEW

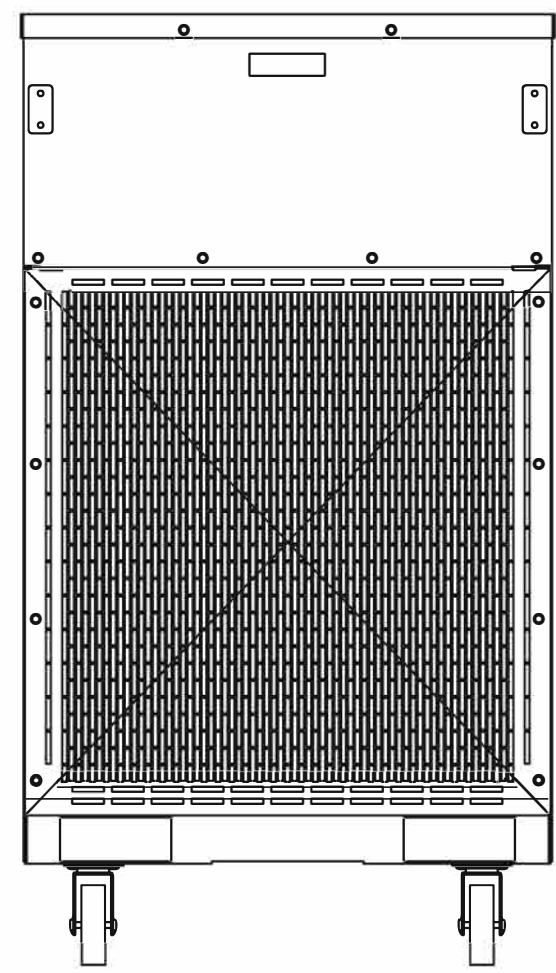

REAR VIEW (EXHAUST END)

THIS DRAWING IS PROPERTY OF LOAD BANKS DIRECT AND SHALL REMAIN SO WHILE IN USER'S POSSESSION. THE TECHNOLOGY SHOWN HERE IS STRICTLY PROPRIETARY AND IS NOT TO BE DISCLOSED TO ANY 3RD PARTY WITHOUT LOAD BANKS DIRECT PRIOR CONSENT.

- GENERAL NOTES:**
- A. UNLESS OTHERWISE NOTED:
1. ALL DIMENSIONS ARE IN INCHES. EXCEPT "[xxx]" = mm.
 - B. APPROXIMATE WEIGHT: 1300 LBS [590 KG].
 - C. SEE ELECTRICAL SCHEMATIC FOR LOAD CAPACITY (KW) RATINGS, VOLTAGE RATINGS, AND BLOWER MOTOR RATING (H.P.)



TEXT			
DWG. NO.	REV.	SHEET	
LP400H-RX-OL	-	1 of 1	
DRAWN BY	CHK'D BY	DATE	SIZE
JJF	MMP	10-23-18	A