

# Mini Tuff Panel - 6 x 20A Quad

Portable Power Distribution



## APPLICATION RANGE

Trystar Mini Tuff Panel  
200A 208/120V

## STANDARD FEATURES

- NEMA 3R all aluminum construction,
- Heavy-duty stackable legs w/ built-in handles or heavy-duty stackable cage
- Custom powder coat
- Custom UV-printed graphics
- Made in USA

## CONFIGURATION

- Input
  - 1 Set of 16 Series Male Panel Mounts  
(BK, RD, BE, WT, GN)
- Output
  - 6 x 20A L21-20 Wet Guard Receptacles
  - 18 x 20A 1P Circuit Breaker

## LISTINGS

- UL1640 Listed
- C(ETL) Listed
- UL 50 Listed
- NEMA 3R

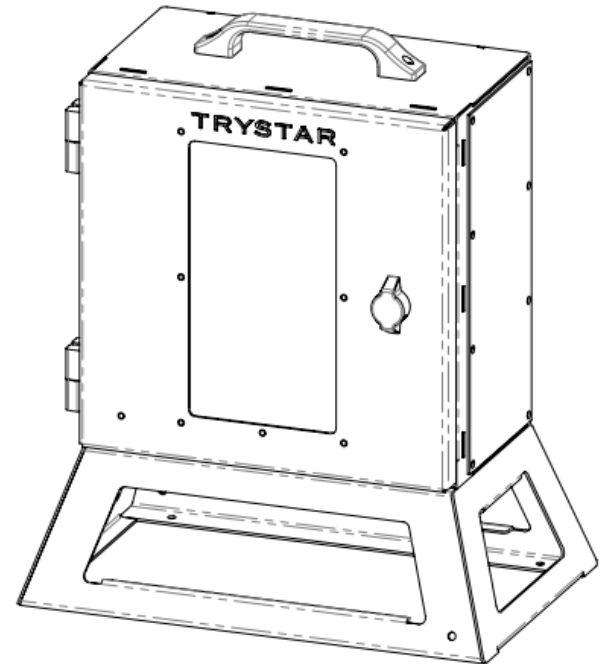

\*Images are representative, specific final design details may vary

# Mini Tuff Panel - 6 x 20A Quad

## DIMENSIONS AND WEIGHTS



APPROXIMATE WEIGHT: 55 LBS.

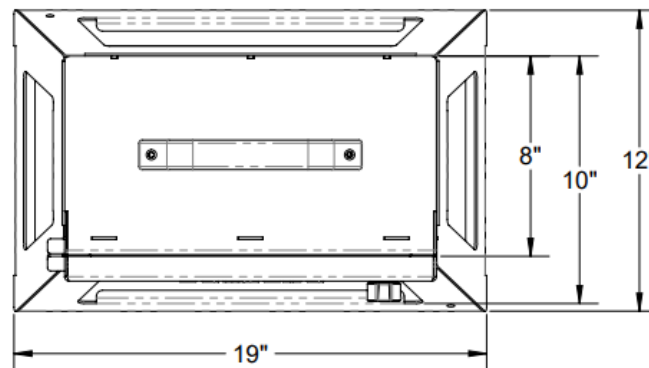
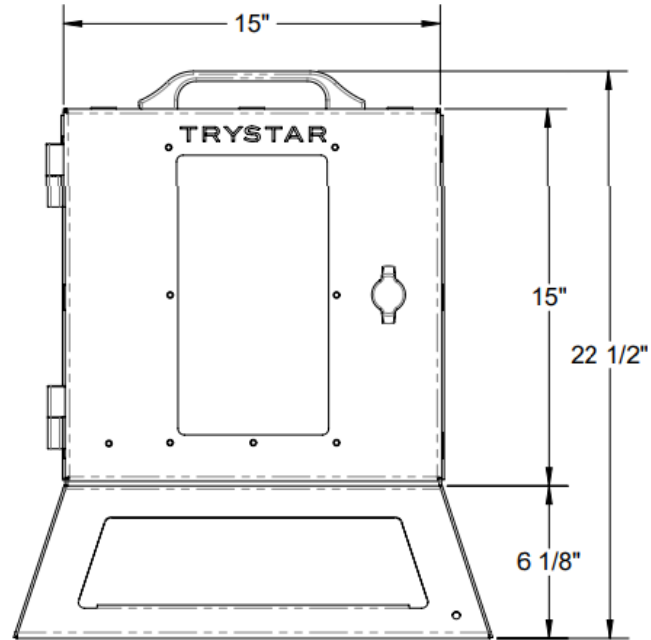

\*Dimensions are representative, specific final design details may vary