

Summary

The RS-485 standard defines a multi-point data communications interface using a balanced-pair (plus common) called “2-wire.” However, many devices use a 4-wire implementation, introducing potential interoperability problems. This document illustrates examples of mixing 2-wire and 4-wire devices using the Trystar CNV-100 converter.

Introduction

The EIA/TIA-485 standard, by the Telecommunications Industry Association, more commonly known as RS-485, specifies electrical characteristics for multi-point, balanced differential data communications systems. The Modbus® protocol is one of many that uses the RS-485 interface as its physical layer for serial data communications. Others include Profibus®, BACnet and simple ASCII.

Topology

The general topology for an RS-485 network consists of a balanced pair and a common, as shown below. At any given time, only one driver has the right to transmit. Note that although this topology is called “2-wire,” a third wire (shield) is typically used as a common reference.

In addition, many devices implement RS-485 using 4 wires plus common (“RS-485 4-wire”) using two balanced pairs instead of one, separating the transmit and receive lines. Mixing 2-wire and 4-wire devices in the same system requires a thorough understanding of device characteristics and proper engineering of the network. Alternatively, a converter designed for this purpose may be used.

Mixing 2-Wire and 4-Wire Devices

To simplify the connection of 2-wire and 4-wire devices in the same system, Trystar offers the CNV-100 RS-485 2-wire to 4-wire converter. This device is preengineered to allow interoperability of 2-wire and 4-wire RS-485 devices in a variety of configurations.

CNV-100 RS-485 2-Wire to 4-Wire Converter

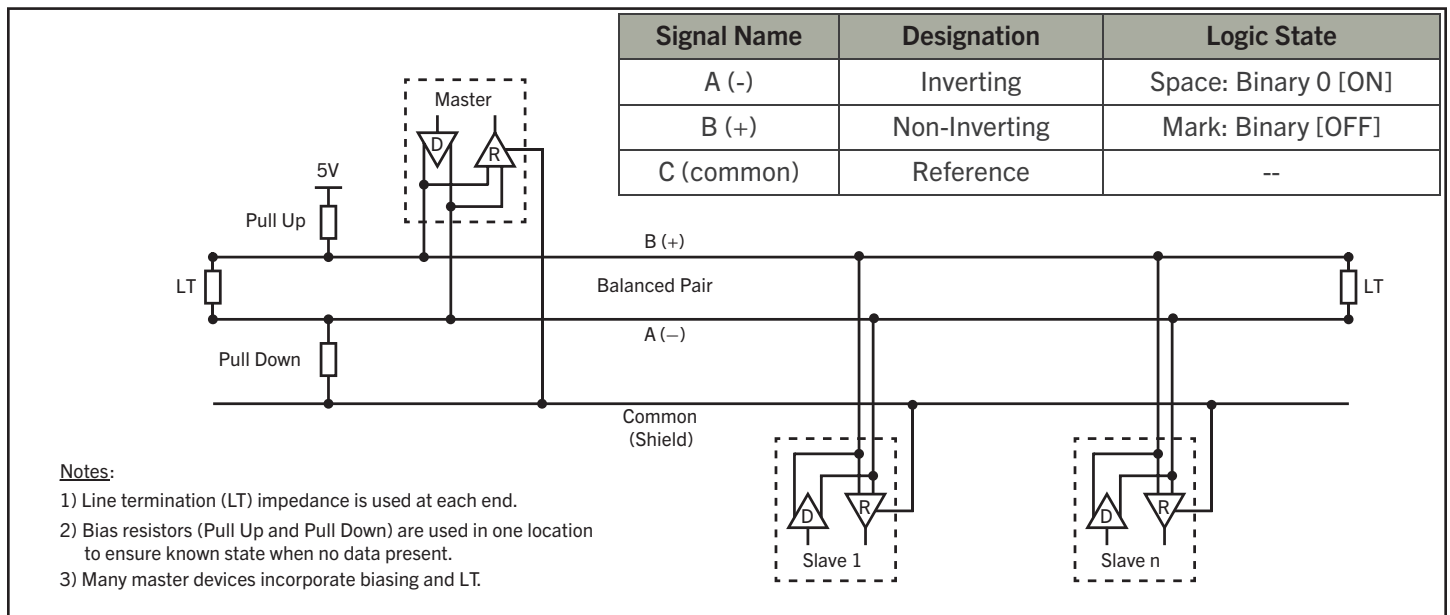

General RS-485 network topology (“2-wire”)

CONVERTING 2-WIRE TO 4-WIRE (OR VICE-VERSA)

CNV-100 RS-485 Converter

The CNV-100 RS-485 converter can be used to connect RS-485 2-wire devices or networks to 4-wire devices or networks. The CNV-100 has been tested with Modbus devices on networks operating at speeds of 9600, 19200, and 38400 bps (half duplex). Other speeds are *not* supported. Most other protocols are also supported, as long as they adhere to the RS-485 standard. No configuration or adjustment of the CNV-100 is required. To ensure proper operation, line termination should be provided at the end of the daisy chain, and the shield grounded at one end only.

Bridging 2-wire and 4-wire networks (2-wire master)

The drawing below shows how the CNV-100 can be used to bridge 2-wire and 4-wire networks (where the master is a 2-wire device).

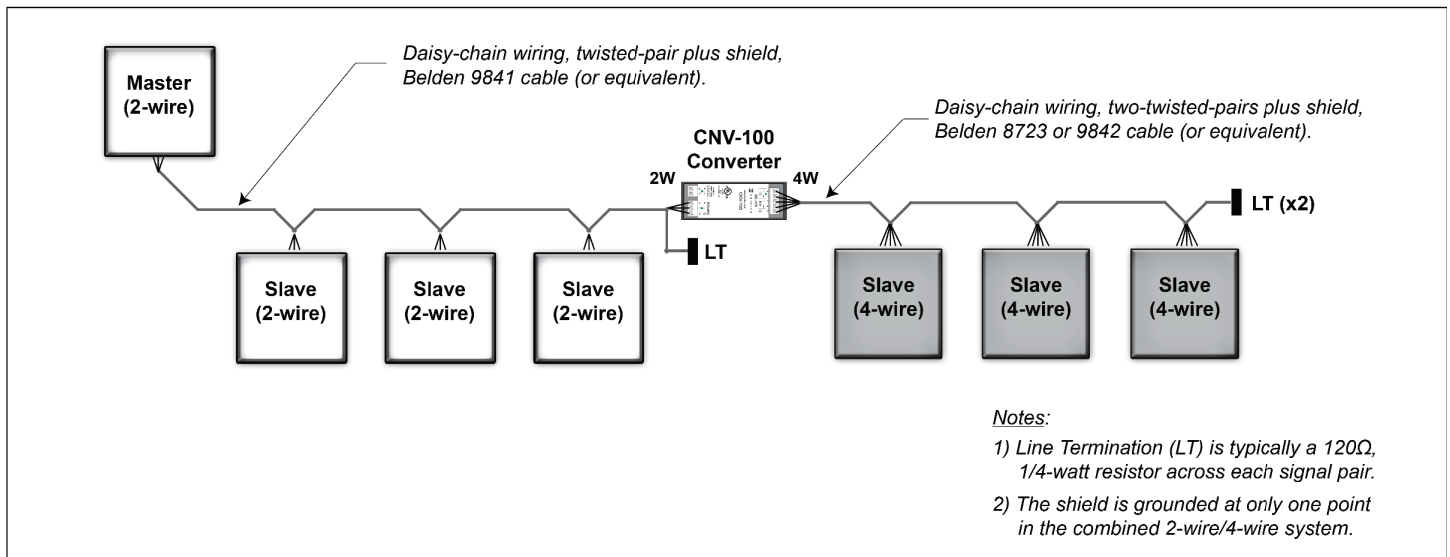

Bridging a 2-wire network (2-wire master) and a 4-wire network

Bridging 4-wire and 2-wire networks (4-wire master)

The drawing below shows how the CNV-100 can be used to bridge 4-wire and 2-wire networks (where the master is a 4-wire device).

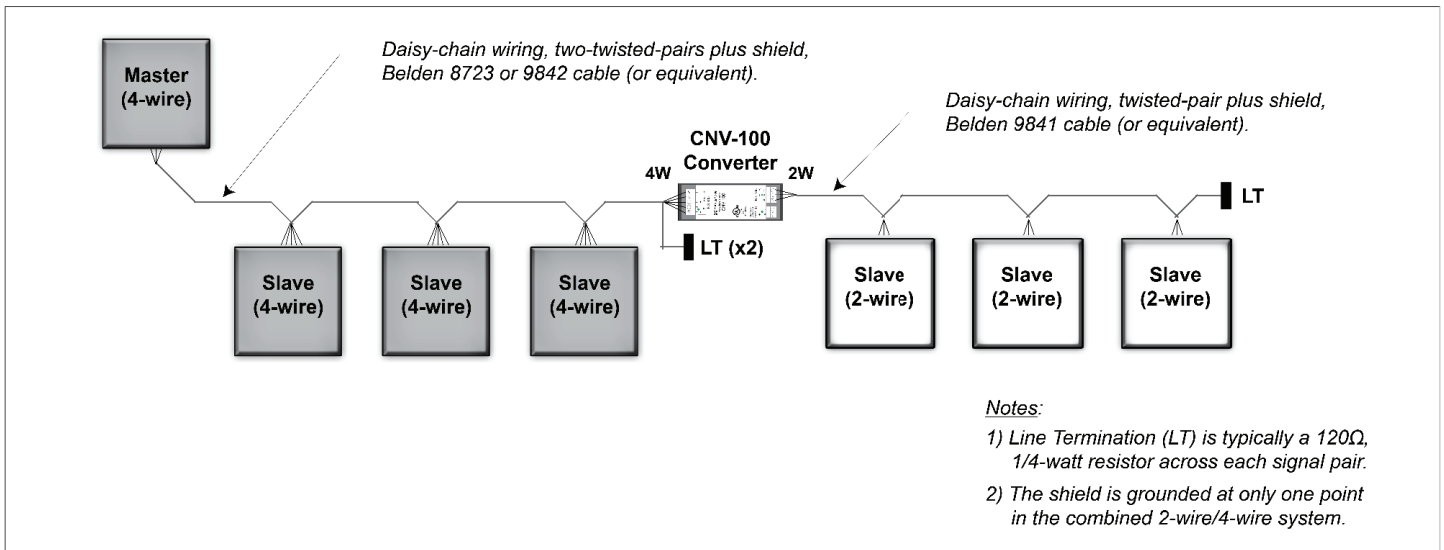

Bridging a 4-wire network (4-wire master) and a 2-wire network

Connecting a 4-wire device to a 2-wire network

The drawing below shows how the CNV-100 can be used to connect a 4-wire device to a 2-wire network (2-wire master).

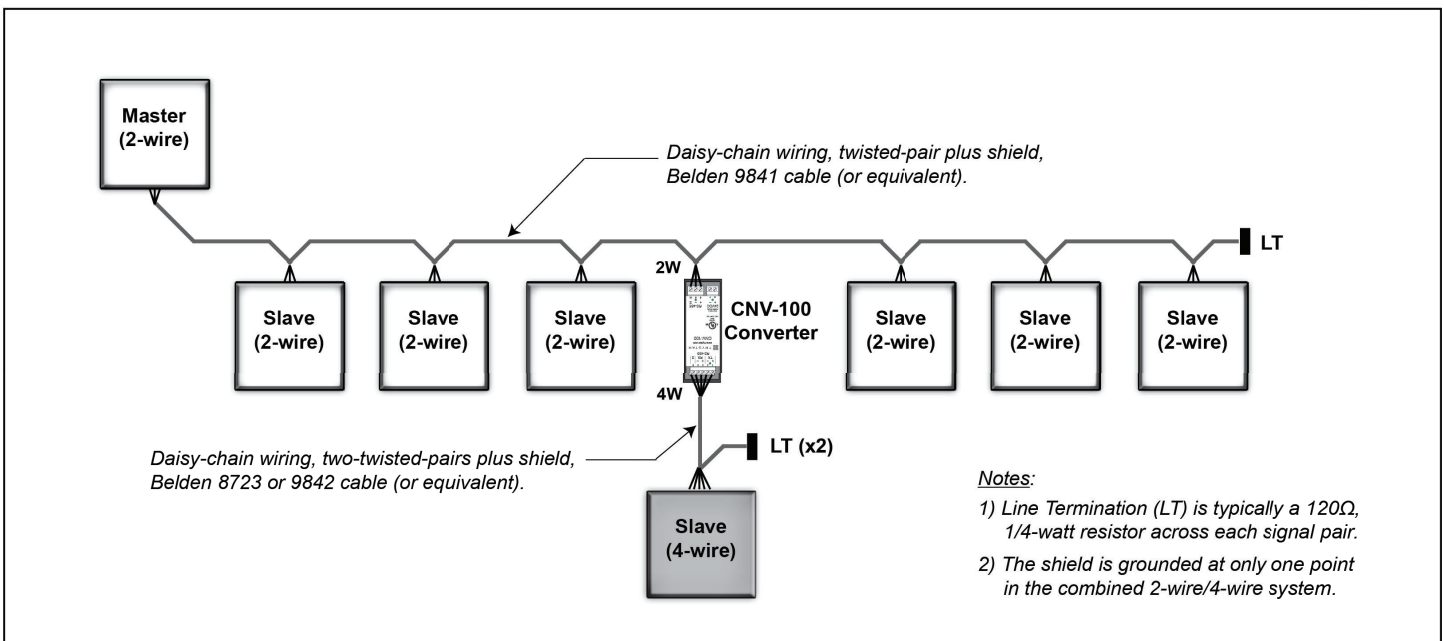

Connecting 4-wire device(s) to a 2-wire network (2-wire master)

Connecting a 2-wire device to a 4-wire network

The drawing below shows how the CNV-100 can be used to connect a 2-wire device to a 4-wire network (4-wire master).

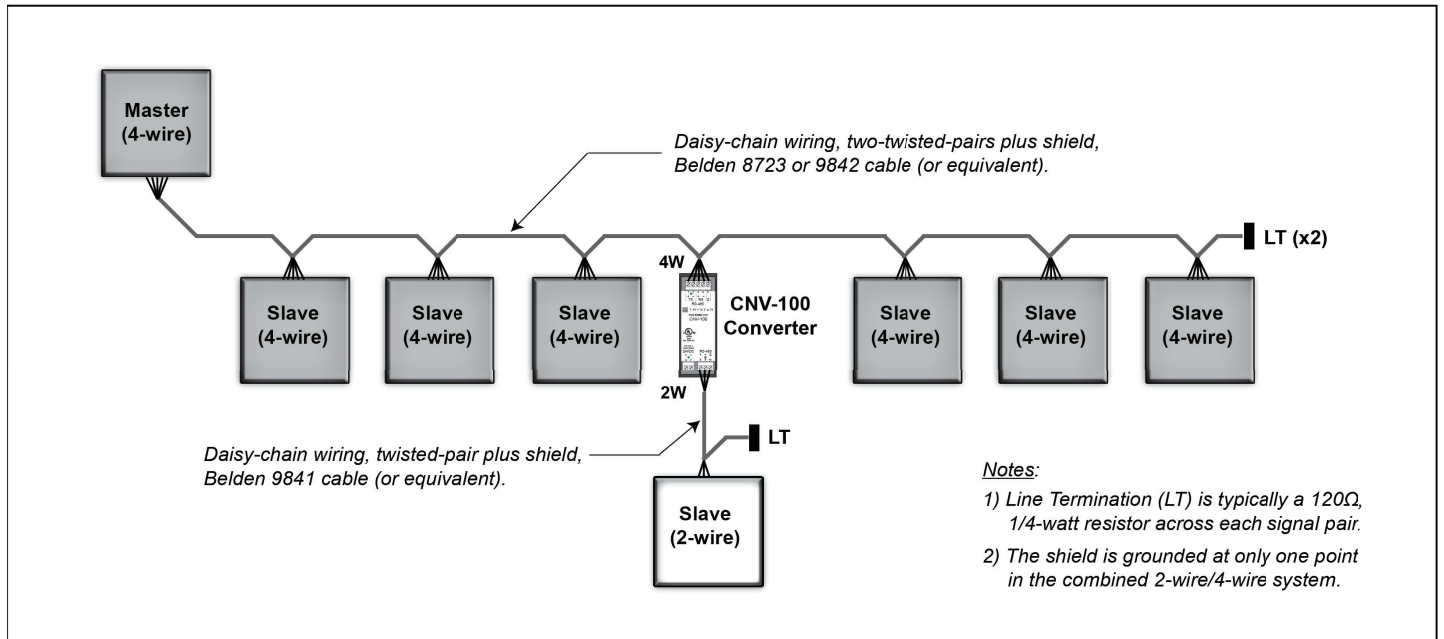

Connecting 2-wire device(s) to a 4-wire network (4-wire master)

Hybrid system: connecting multiple 4-wire devices to a 2-wire network

The drawing below shows how the CNV-100 can be used to connect multiple 4-wire devices to a 2-wire network (2-wire master). Since the CNV-100 is separately powered (24 Vdc), the same distance/speed limitations are applicable for the 4-wire portion as the 2-wire segment. The 2-wire and 4-wire daisy chains each have their own line termination; however, the combined system should have its shield grounded in one location only (normally at the master device).

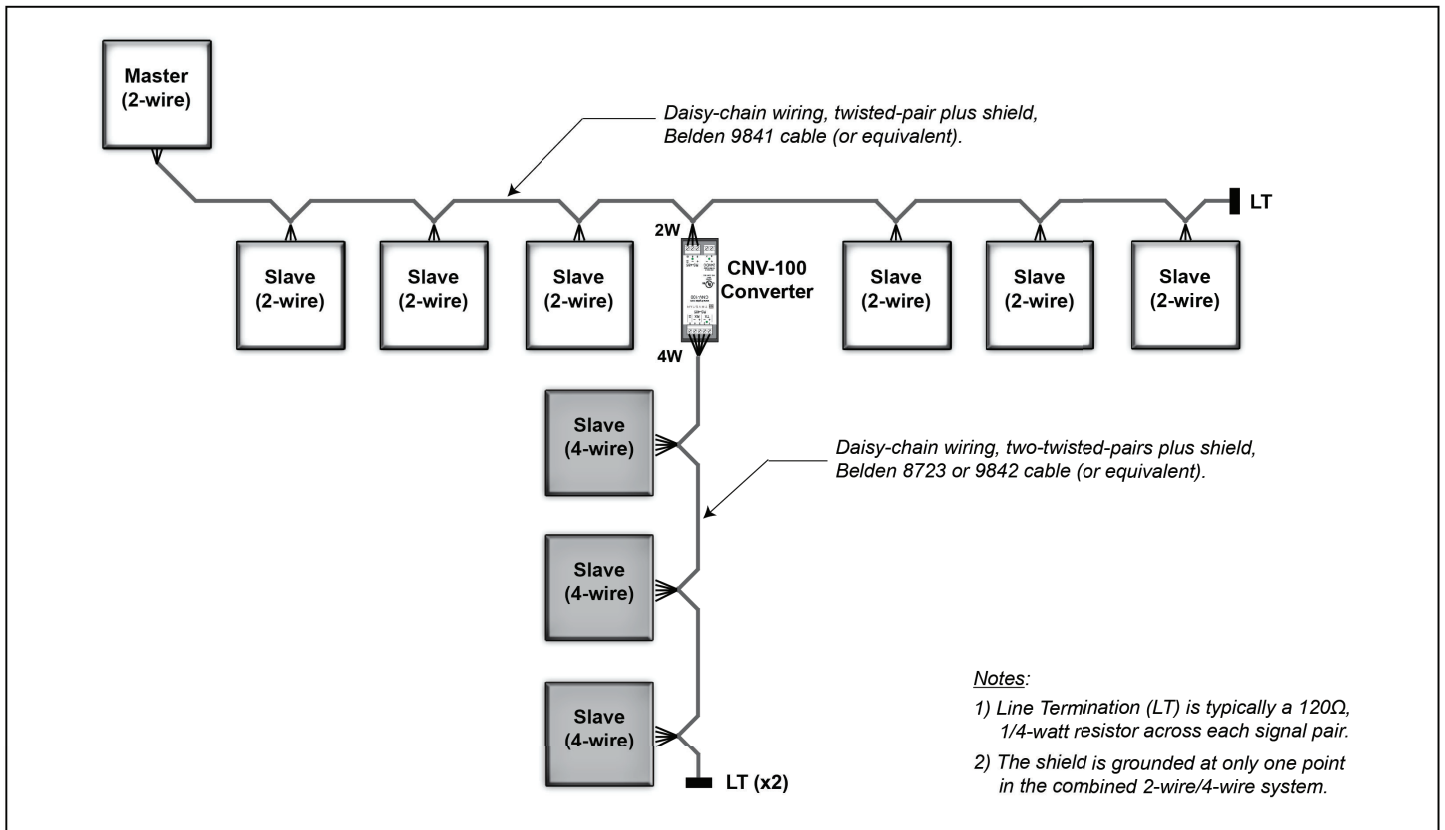

Hybrid system example: 2-wire network (2-wire master) with T-connection of 4-wire networkMaster

SUMMARY

Summary

The RS-485 standard electrical interface serves as a basis for Modbus protocol and others for serial data communications networks, and both 2-wire and 4-wire implementations are supported. This can introduce interoperability problems unless special care is taken during system design. The CNV-100 converter from Trystar can be applied in a variety of system architectures to ensure reliable operation.

For custom applications not specifically covered in this document, or for help in designing the system architecture that best meets your requirements, please contact Trystar.

References

Electrical Characteristics of Generators and Receivers for Use in Balanced Digital Multipoint Systems, TIA/EIA-485-A, March 1998, Telecommunications Industry Association.

Application Guidelines for TIA/EIA-485-A, TSB89, June 1998, Telecommunications Industry Association.

MODBUS over Serial Line Specification and Implementation Guide, V1.02, Dec 20, 2006. www.modbus.org.

