

Overview of DCF77 Time Protocol

Summary

DCF77 is a precision time protocol used to synchronize power system devices in time-critical applications.

This document describes the protocol, gives examples of Trystar products that support DCF77, and describes how this legacy protocol is being replaced by PTP (Precision Time Protocol per IEEE 1588) in modern power system applications.

Introduction

DCF77 is a time synchronization protocol with its origin in Europe. DCF77 was developed by the Physikalisch-Technische Bundesanstalt (PTB), the national institute for science and technology in Braunschweig, Germany. DCF77 is both a longwave time signal and a radio station used by the PTB to transmit a precision time signal. The radio station has been in operation since 1959.

DCF77 is similar to WWVB (USA) and MSF (UK). When used as an electrical signal, the DCF77 time code is transmitted as a 24Vdc pulse-width modulated signal that provides a complete date/time string once every minute. The signal contains a one-pulse-per-second component that is accurate to 100 microseconds in reference to UTC (Coordinated Universal Time). Each minute, a pulse-string contains a BCD (Binary Coded Decimal) value for minute, hour, day, day of week, month, and year as well as other control parameters such as leap second and Daylight Saving Time (Summer Time).

DCF77 STANDARD

Note: DCF77 stands for:
 D=Deutschland
 C=long wave signal
 F=Frankfurt
 77= 77.5kHz.

DCF77 Time Code Pulse

Each DCF77 pulse has a logical value of either 0 or 1 based on its width (duration). The figure below provides a description of the pulse-width modulation (at 24 Vdc nominal) utilized in the DCF77 protocol.

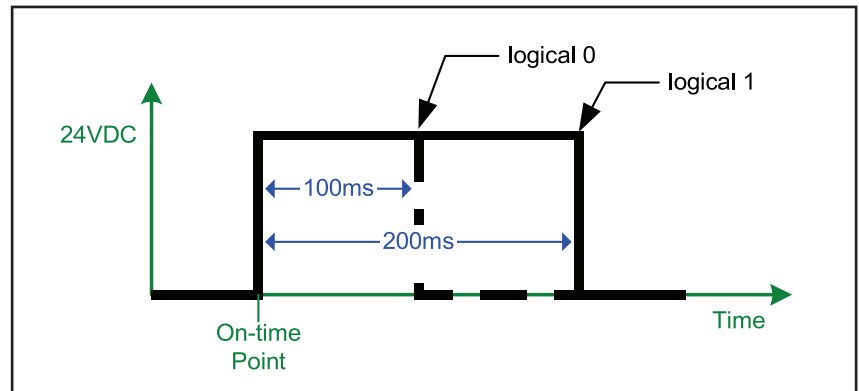

DCF77 pulse-width coding

DCF77 IMPLEMENTATION

DCF77 in Power System Devices

DCF77 uses 24 Vdc nominal voltage; therefore, it can be distributed to multiple devices over long distances, making it well-suited to power and automation applications. Thanks to its relatively low bit-rate of 1 pulse-per-second and time frame of 1 minute (compared to 100 pps and 1 second for IRIG-B), DCF77 requires less processor overhead, yet can achieve equivalent accuracies.

DCF77 TIME CODE

DCF77 Time Signal Coding

The DCF77 time code provides a complete date/time string once every minute. Each minute, a pulse-string contains a BCD (Binary Coded Decimal) value for minute, hour, day, day of week, month, and year as well as other control parameters such as leap second and Daylight Saving Time (Summer Time) as shown below.

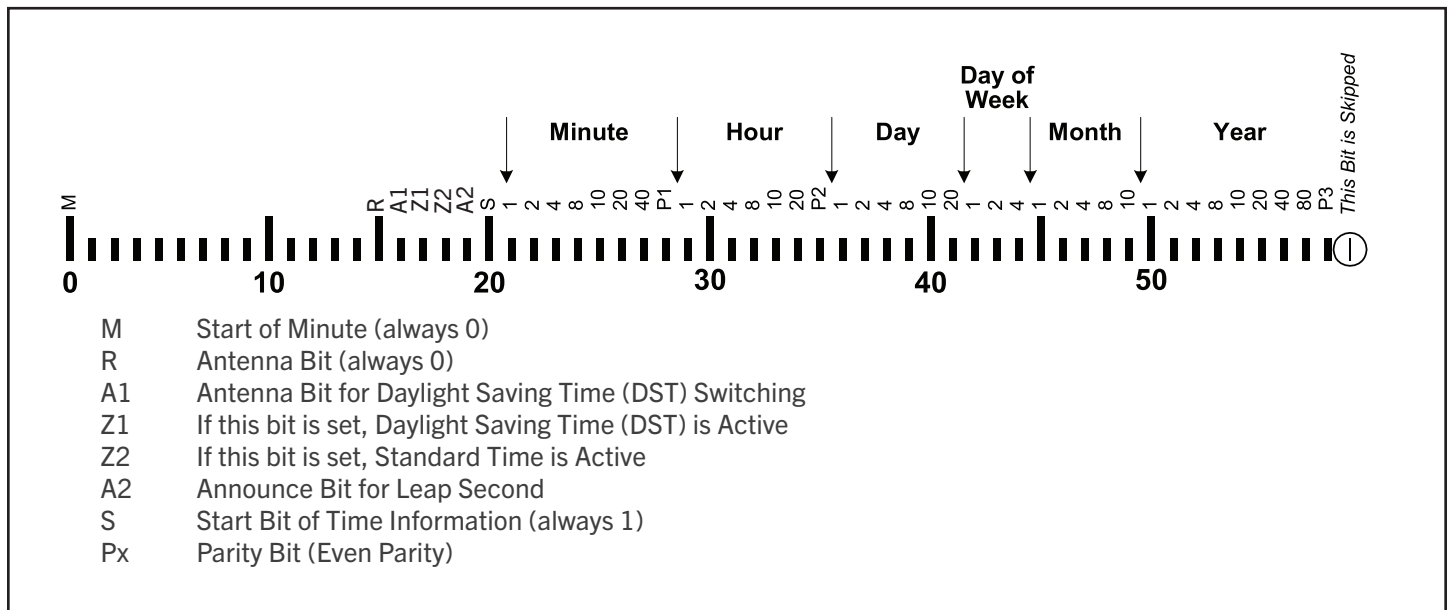

DCF77 time signal coding

DCF77 WIRING

Note: Because the DCF77 signal consists of a series of pulses, a digital scope is needed for diagnostics; a standard multi-meter is not sufficient to confirm normal operation.

APPLICATIONS OF DCF77 IN TRYSTAR PRODUCTS

DCF77 Implementation

Since DCF77 was originally defined as a radio broadcast signal, specific signal levels for DCF77 are not defined in any standard. The most common techniques for transmission of DCF77 (DCLS) is its multi-point distribution as a 24V signal over shielded twisted-pair cable. This signal is wired to a general-purpose or dedicated digital input, configured to decode the DCF77 signal.

Application considerations

When applying DCF77, the number and type of devices to be synchronized and the distances involved affect system architecture; therefore, each system must be engineered individually.

DCF77 sources from Trystar (described later) are capable of synchronizing up to 16 devices on a single daisy-chain. A larger number of devices may require multiple circuits, repeaters and/or isolation means.

Trystar Sequence of Events Recorder

Trystar Sequence of Event Recorders (SER-32e, SER-3200 and SER-2408 models) accept DCF77 as time source, then sync with each other using PTP. As described previously, a PTP slave can also output DCF77 to devices that do not support PTP. Other time-sync input and output options are also supported for flexibility and interoperability with other devices.

SER TIME SOURCE OPTIONS (Time-Sync IN)

Time source options via PTP, NTP or Modbus TCP use the SER’s built-in Ethernet interface (RJ-45). IRIG-B or DCF77 inputs require an adapter (EZC-IRIG-B or EZCDF77) as shown.

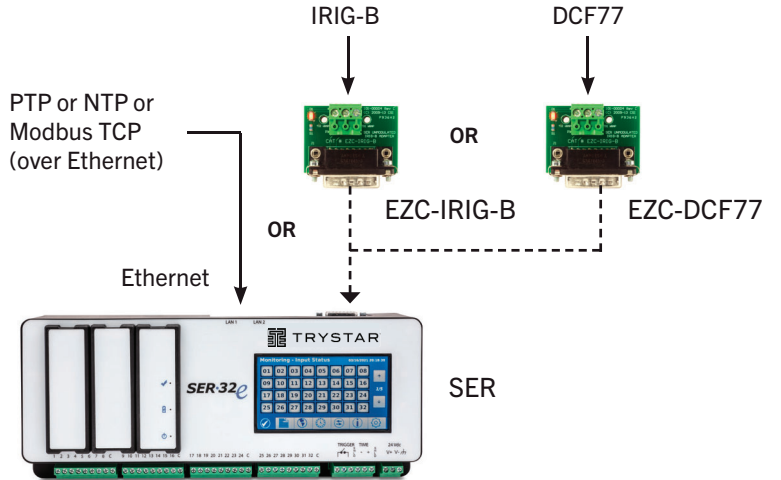

SER AS TIME-SYNC HUB (Time-Sync OUT)

When PTP is selected as time source, the SER also serves as a “PTP time-sync hub” for non-PTP devices, generating the time-sync protocol needed: IRIG-B, DCF77, 1per10 (via PLX adapter) or ASCII (via built-in RS-485 port), as shown below.

Note: Only one protocol can be selected for output via the PLX connector (IRIG-B, DCF77 or 1per10). However, for maximum flexibility, the ASCII / RS-485 output is enabled by default any time an SER is set to use PTP for time source (IN) or time-sync (OUT).

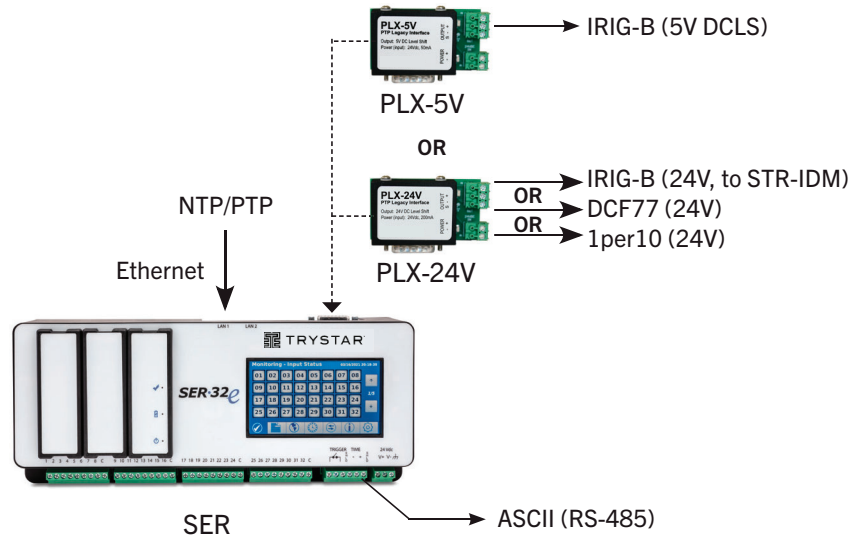

APPLICATIONS OF DCF77 IN TRYSTAR PRODUCTS (CONT.)

If Modulated IRIG-B input is used, the STR-100 must be configured with the current year during initial setup. The full date/time (including the year) is transmitted via its DCF77 outputs.

STR-100 Satellite Time Reference

The Trystar STR-100 Satellite Time Reference accepts a GPS smart antenna input or a modulated IRIG-B signal (type B122). The STR-100 then outputs a DCF77 signal on two channels (CH1 and CH2). By connecting devices in a daisy-chain configuration, the STR-100 can provide an accurate time reference for up to 32 power system devices, with accuracy of 100 microseconds.

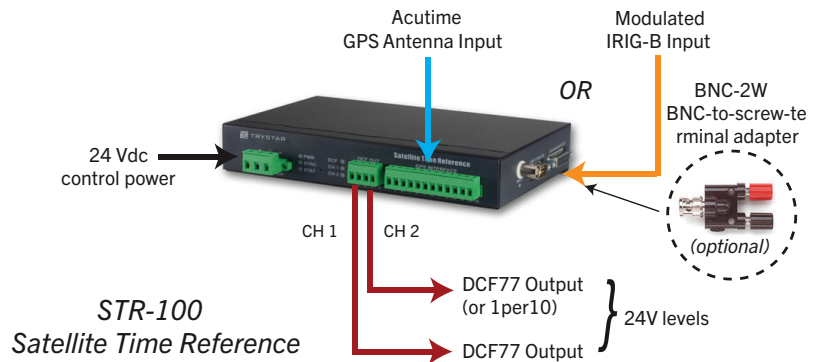

PRECISION TIME PROTOCOL (PTP) PER IEEE 1588

For More Info on PTP:
Tech Note: Hi-res Time Sync using PTP/1588

Time Synchronization as Easy as 1-2-3

PTP (Precision Time Protocol defined in IEEE 1588) takes advantage of hardware-assisted timestamping to achieve sub-millisecond time synchronization over an Ethernet network. Trystar offers simple, scalable system architectures using PTP as the means to distribute a precise time reference to all devices that support PTP. SERs accept a variety of time-source options, and sync with each other automatically over Ethernet, using PTP. In addition, an SER can serve as a “PTP time sync hub” for devices that do not yet support PTP.

Simple, building-block options are shown below. The first Trystar SER accepts a time reference signal (such as IRIG-B or DCF77), then serves as PTP master clock for all other SERs as well as other devices which support PTP. For a device that does not support PTP, a nearby SER outputs the protocol needed (e.g., DCF77) effectively making this device “PTP-enabled” as well.

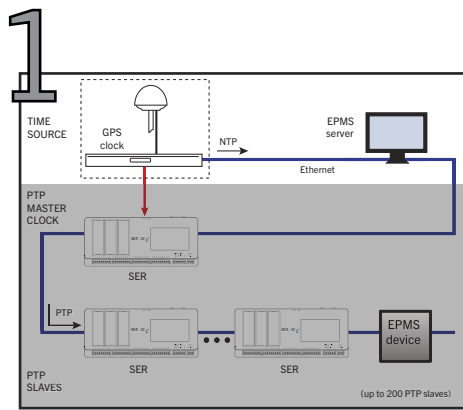

Choose a Time Source

Set the first SER's time from a web browser, EPMS software or NTP server. Optionally, add a GPS antenna/receiver to provide an external time reference traceable to UTC (Coordinated Universal Time), to compare data from other sites or organizations (e.g., electric utilities).

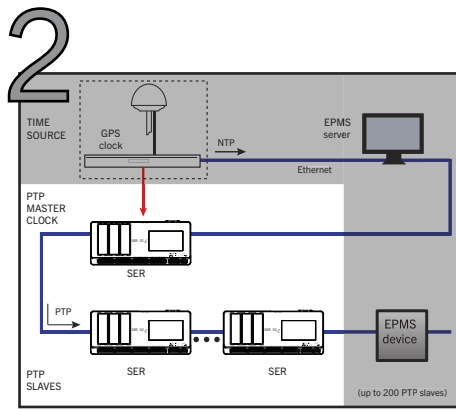

Sync all SERs with Each Other (PTP)

Configure the first SER to output PTP (PTP grandmaster clock); all other SERs on the same Ethernet network sync with each other automatically (within 100 μsec). No special Ethernet switches. No additional setup. Simple, affordable, scalable.

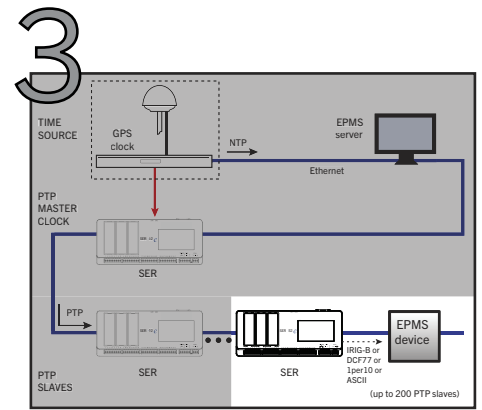

Sync Other EPMS Devices

Sync SERs with other EPMS devices using PTP over Ethernet, all within 100 μsec. No PTP? No problem! For devices that do not yet support PTP, a Trystar SER (PTP slave) can serve as a “time-sync hub” to output the legacy protocol needed (IRIG-B, DCF77, ASCII, or 1per10).

SYNCHRONIZING NON-PTP DEVICES (via DCF77)

Time-sync Output: DCF77

A Trystar SER (with PTP enabled) can be configured to output DCF77 to one or more devices. A PTP Legacy Interface (PLX-24V) connected to the SER DB-15 port outputs the signal at 24 Vdc nominal. Generally, the choice to use DCF77 is dictated by the device(s) that require this method for time sync. This protocol is most commonly used by PowerLogic™ CM4000 series meters from Schneider Electric and Power Xpert™ PXM 4000/6000/8000 meters from Eaton.

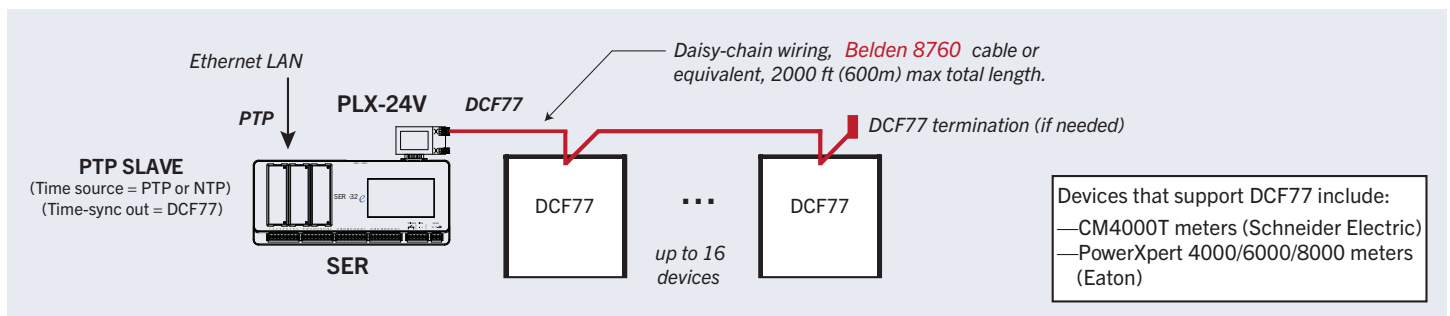

EPMS SYSTEM EXAMPLE (Devices require IRIG-B and DCF77)

An EPMS (Electrical Power Management System) example is shown below that uses PTP for time synchronization over Ethernet, with IRIG-B from the time source (GPS clock) and SERs as PTP time-sync hubs to output IRIG-B or DCF77 to devices that do not support PTP directly.

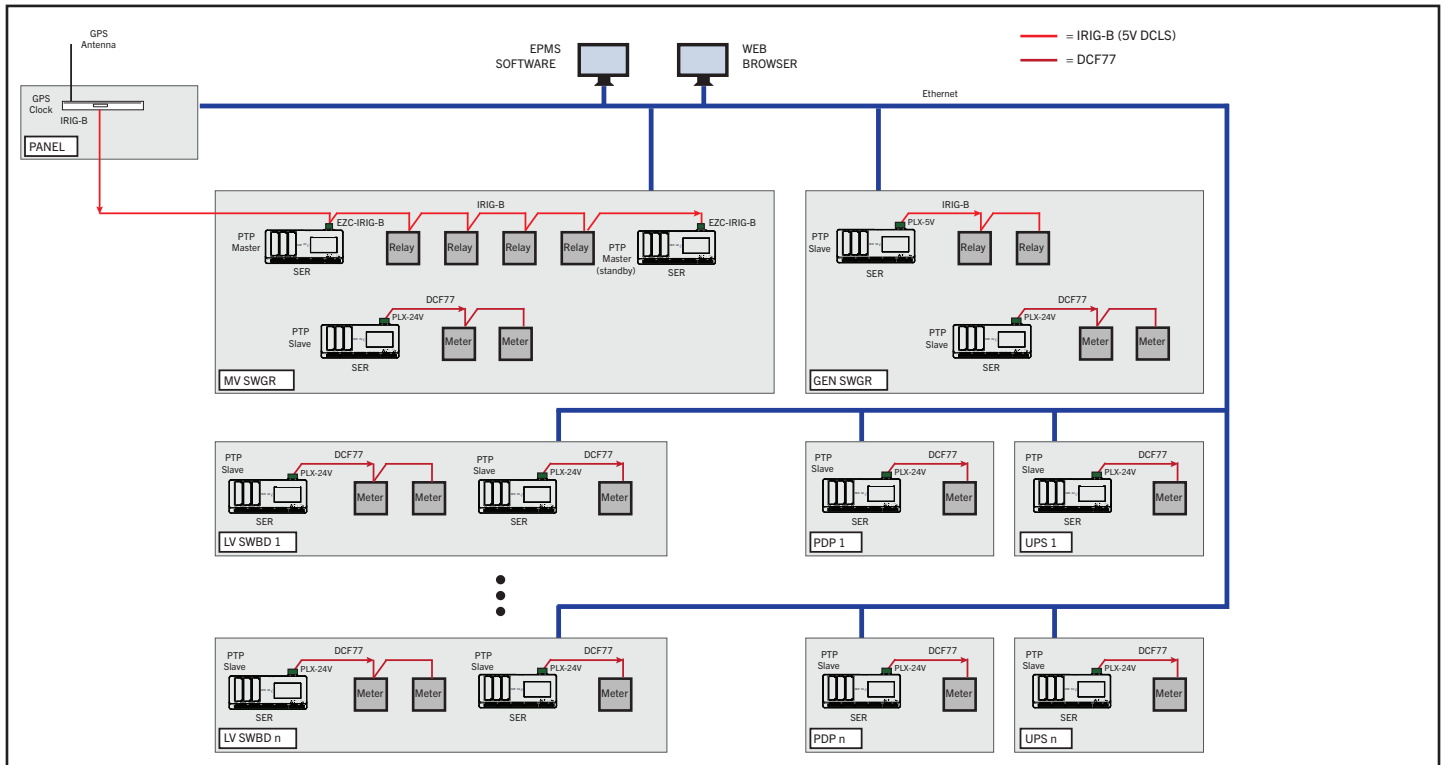

EPMS SYSTEM EXAMPLE—PTP-ENABLED DESIGN (IRIG-B AND DCF77)

REFERENCES

References

1. The Physikalisch-Technische Bundesanstalt (PTB) web site.
http://www.ptb.de/index_en.html
2. “DCF77 time code” — from the PTB web site.
http://www.ptb.de/en/org/4/44/442/dcf77_kode_e.htm
3. “DCF77 longwave time signal” — from Meinberg GmbH. web site.
<http://www.meinberg.de/english/info/dcf77.htm>
4. Kennedy, Robert A., P.E., “GPS Time Synchronization: How precision timing and sequence of events recording will make the Smart Grid even smarter,” Electrical Construction & Maintenance (EC&M) magazine, August 19, 2011, pp. 18-20.
<http://ecmweb.com/computers-amp-software/gps-time-synchronization>
5. Brown, PE, Bill, and Mark Kozlowski, “Power System Event Reconstruction Technologies for Modern Data Centers,” Square D Critical Power Competency Center. Aug. 2006.

