

## Sequence of Events Recording (SER) System Design Guide

Modern power systems rely on precision timing. Sequence of Events Recording (SER) systems use 1-msec timestamp resolution to provide essential information about power system events. PTP (Precision Time Protocol defined in IEEE 1588) uses hardware-assisted timestamping to achieve required accuracy over Ethernet, finally making “high-definition” time sync simple and affordable. This document describes simple, scalable system architectures using PTP with products from Trystar. In addition, various options are described for integrating devices using legacy time protocols.

### Time Synchronization as Easy as 1-2-3

Time synchronization requires a time source and a means to distribute this time reference to all devices. For precision time sync, devices don’t just “snap” to the new time value at each update; they learn to “beat in rhythm” with the master clock, maintaining precise synchronization at all times. Trystar SER-3200/2408-PTP Event Recorders accept a variety of time-source options, and sync with each other automatically over Ethernet, using PTP. In addition, an SER can serve as a “time sync hub” for devices that do not yet support PTP.

Simple, building-block options are shown below, and more technical details are presented in the rest of this document.

## TIME SYNCHRONIZATION DESIGN

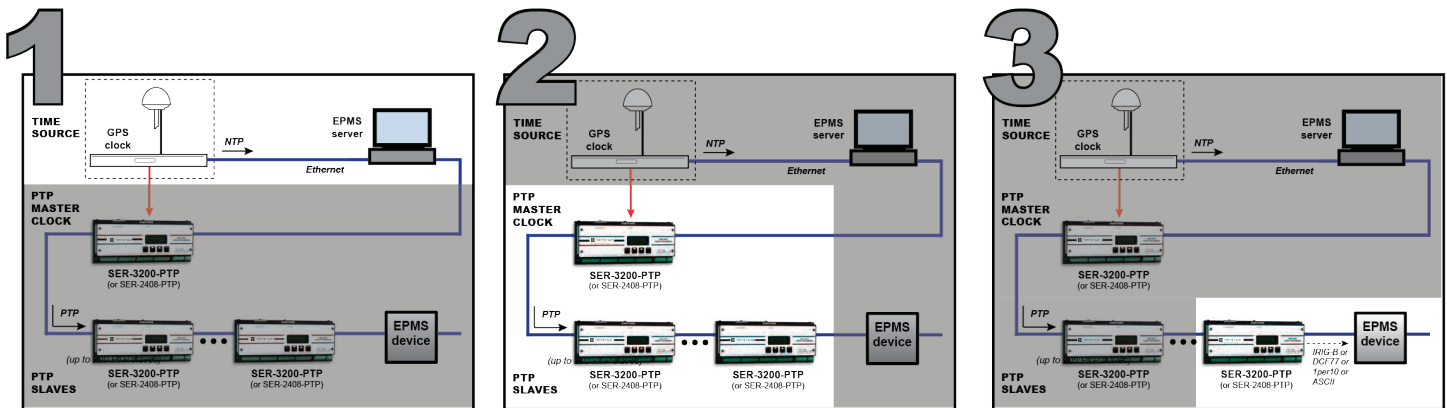

### Choose a Time Source

Set the first SER’s time from a web browser, EPMS software or NTP server. Optionally, add a GPS antenna/receiver to provide an external time reference traceable to UTC (Coordinated Universal Time), to compare data from other sites or organizations (e.g., electric utilities).

### Sync all SERs with Each Other (PTP)

Configure the first SER to output PTP (PTP grandmaster clock); all other SERs on the same Ethernet network sync with each other automatically (within 100  $\mu$ sec). No special Ethernet switches. No additional setup. Simple, affordable, scalable.

### Sync Other EPMS Devices

Sync SERs with other EPMS devices using PTP over Ethernet, all within 100  $\mu$ sec. No PTP? No problem! For devices that do not yet support PTP, a Trystar SER (PTP slave) can serve as a “time-sync hub” to output the legacy protocol needed (IRIG-B, DCF77, ASCII, or 1per10).

---

## TABLE OF CONTENTS

|  |    |
|--|----|
| PTP (IEEE 1588) INTRODUCTION -----     | 3  |
| SER TIME SYNC INPUTS/OUTPUTS -----     | 4  |
| 1—TIME SOURCE OPTIONS -----            | 6  |
| 2—TIME DISTRIBUTION (PTP)-----         | 10 |
| 3—SYNCHRONIZING NON-PTP DEVICES -----  | 11 |
| REDUNDANT MASTERS -----                | 16 |
| SCALABILITY-----                       | 17 |
| EPMS SYSTEM EXAMPLES -----             | 18 |
| LEGACY SYSTEM ARCHITECTURES -----      | 31 |
| UPGRADING A LEGACY DESIGN TO PTP ----- | 36 |
| EXTENDING EXISTING TIME SYNC -----     | 41 |
| TECHNICAL REFERENCE-----               | 44 |

# PRECISION TIME PROTOCOL (PTP) per IEEE 1588

## Precision Time Protocol (PTP) per IEEE 1588

IEEE 1588™ defines the Precision Time Protocol (PTP) with a goal of achieving very high precision for time-synchronization over a packet-based network such as Ethernet. PTP takes advantage of special Ethernet hardware for precise time-stamping of the Ethernet frame send and receive time and prescribes a very precise mechanism to correct for delays introduced in the network path from the master clock (time reference), through multiple levels of switches, to the slave clocks (time consumers).

### The Power Profile—Not for Everyone

A second IEEE standard (IEEE C37.238) proposes a unique subset of attributes and settings (“Power Profile”) optimized for certain power system applications. However, the name is unfortunate, because it is mainly intended for applications that require 1-μsec accuracy, such as synchrophasors for electric utility substation automation. By contrast, in commercial/industrial power applications, where 100-μsec accuracy is sufficient to achieve meaningful 1-msec timestamp resolution, the Power Profile’s strict rules add unnecessary cost, making it unsuitable.

### The Simple PTP Profile—Based on IEEE 1588 Default Profile

The Power Profile requires all Ethernet switches to be 1588-compliant to serve as “transparent clocks” and adjust PTP packets “on the fly.” This is required to achieve 1-μsec accuracy but unnecessary for less-demanding applications such as Sequence of Events Recording (SER). For these, Trystar proposes the “Simple PTP” (SPTP) Profile, based on the IEEE 1588 Default Profile. This “Goldilocks solution” is just right for commercial/industrial EPMS, ensuring the required accuracy without imposing unnecessary restrictions or changes to the Ethernet data network. With SPTP, *no* special 1588 Ethernet switches are required.

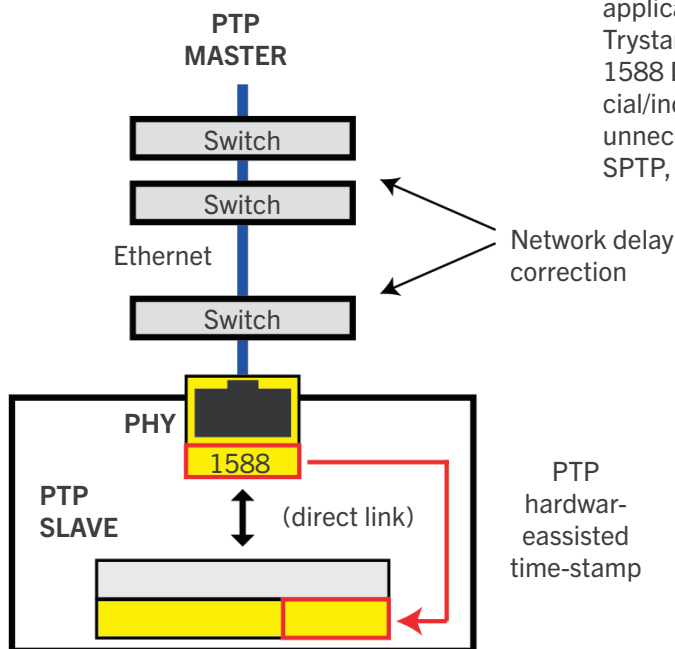

PTP uses 1588 hardware-assisted time-stamping in the Ethernet physical layer (PHY) for high precision

**For More Info:**  
 Tech Note: Hi-res Time Sync using PTP/1588 (TN-100)

| IEEE 1588 (All Profiles)            | “Simple PTP” Profile (SPTP) *              | Power Profile (C37.238)                      |
|-------------------------------------|--|--|
| <b>GENERAL</b>                      | <b>SIMPLE</b>                              | <b>STRICT</b>                                |
| Target accuracy: nanoseconds        | <b>Target accuracy: 100 μs</b>             | Target accuracy: 1 μs                        |
| All clock types                     | Master and Slave-only                      | All clock types except boundary              |
| Unicast or Multicast                | Multicast                                  | Multicast                                    |
| 802.3 (layer 2), UDP/IPv4, UDP/IPv6 | UDP/IPv4                                   | 802.3 only (layer 2)                         |
| PTP-compliant switches              | <b>No special switches required</b>        | PTP-compliant switches required              |
| End-to-end or Peer-to-peer          | End-to-end (E2E) only                      | Peer-to-peer (P2P) only                      |
| 1-step or 2-step                    | 2-step                                     | 1-step or 2-step                             |
| Variable delay requests             | 32 seconds                                 | Variable delay requests (typically 1 second) |
| Does not address max no. of slaves  | <b>Designed to support 200+ PTP slaves</b> | Does not address max no. of slaves (< 40?)   |

\* Simple PTP (SPTP) is based on the PTP Delay Request-Response Default PTP profile (also called End-to-End), defined in IEEE 1588-2008, Annex J.

## TRYPSTAR SER TIME-SYNC OPTIONS (INPUTS AND OUTPUTS)

### Trystar SER-3200-PTP (or SER-2408-PTP)

Trystar SER-3200/2408 Event Recorders are the first Trystar products to support PTP. For both models, PTP functionality is enabled through a license key (hardware versions B1 and later). The PTP license enables both PTP master and PTP slave functionality in the SER. User setup determines whether the device functions as a PTP master or PTP slave (or neither, and is simply installed for future use).

In addition to PTP, SER-3200/2408 Event Recorders support several time-sync input and output options for flexibility and interoperability with other devices.

# SER-3200/2408 Time Source Options (Time-Sync IN)

Time source options via PTP, NTP or Modbus TCP use the SER-3200/2408 built-in Ethernet interface (RJ-45). IRIG-B or DCF77 inputs require an adapter (EZC-IRIG-B or EZC-DCF77) as shown.

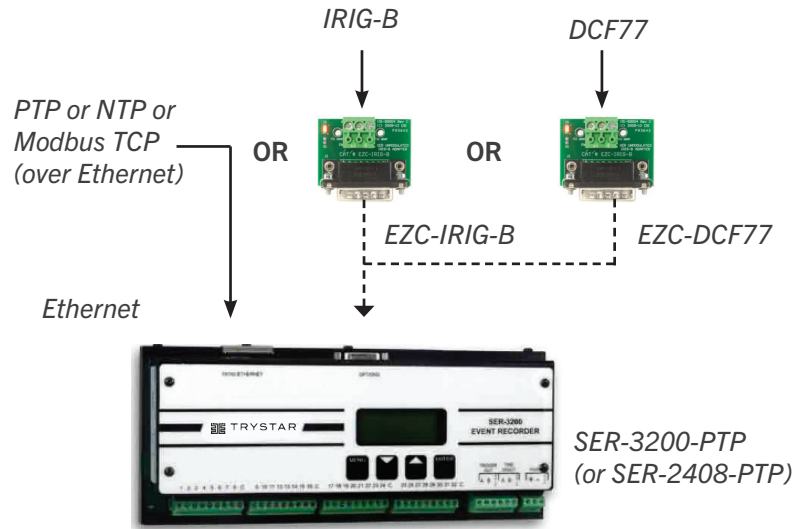

# SER-3200/2408-PTP as Time-sync Hub (Time-Sync Outputs)

When PTP is selected as time source, the SER-3200/2408 also serves as a “PTP timesync hub” for non-PTP devices, generating the time-sync protocol needed: IRIG-B, DCF77, 1per10 (via PLX adapter) or ASCII (via built-in RS-485 port), as shown below.

Note: Only one protocol can be selected for output via the PLX connector (IRIG-B, DCF77 or 1per10). However, for maximum flexibility, the ASCII / RS-485 output is enabled by default any time an SER is set to use PTP for time source (IN) or time-sync (OUT).

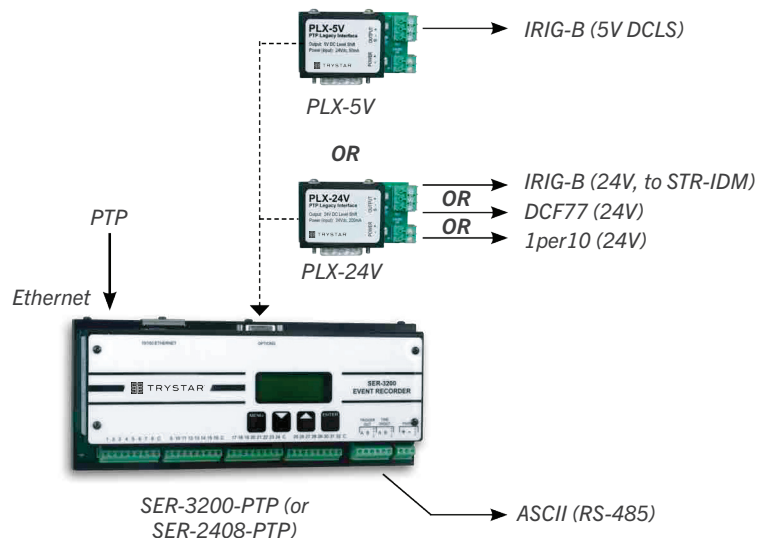

## TIME SOURCE OPTIONS

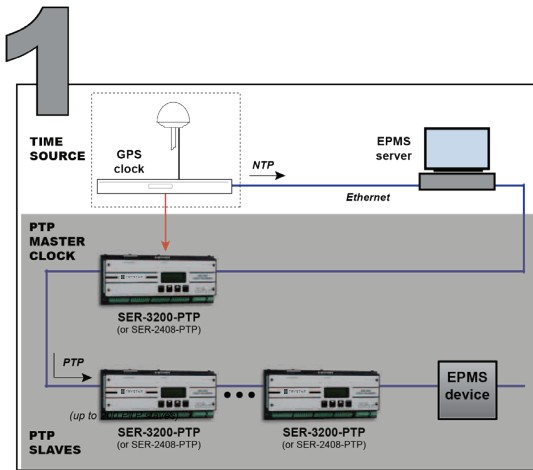

Tryst SER-3200/2408 Event Recorders support several options for setting the time or synchronizing to an external time source. Time source options over Ethernet (PTP, NTP or Modbus TCP) use the built-in Ethernet interface.

The simplest approach is to set the SER date/time manually via its web interface (Setup-Time web page). This is acceptable if only one SER is needed, or for temporary use during commissioning or tests.

Another simple method is to set the date/time over the Ethernet network by the EPMS (or other supervisory) server, using the SER’s Modbus TCP command interface. Note that the EPMS server clock and SER clock may differ by as much as one second with this approach; however, as long as all other SERs (and EPMS devices with 1-msec timestamp resolution) are synchronized more precisely with each other, this may be acceptable.

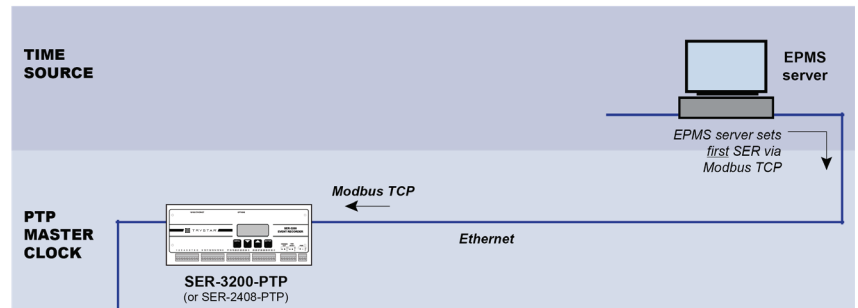

EPMS server sets date/time over Ethernet network, using Modbus TCP

### Time Source: Network Time Server (NTP)

The most widely used method for time synchronization of computers, at least in the past, is to deploy one or more network time servers (NTP servers) on the Ethernet network. Devices must be configured with one or more NTP server IP addresses, and then periodically request the date and time. Depending on network design and the degree of sophistication in the client device’s NTP (or SNTP) algorithm and software design, accuracies of 10-100 msec are possible. There are no objective test standards to guide manufacturers of power system devices, and so specified accuracies—and real-world performance—vary greatly.

For this reason, Trystar recommends setting the *first SER only* to sync to an NTP server; set this SER, in turn, to serve as PTP grandmaster to sync all other SERs (and other PTP-compatible devices) over the network using PTP (Precision Time Protocol). Devices which do not support PTP may use NTP or (if possible) use one of the higher-precision, legacy protocols described later in this document.

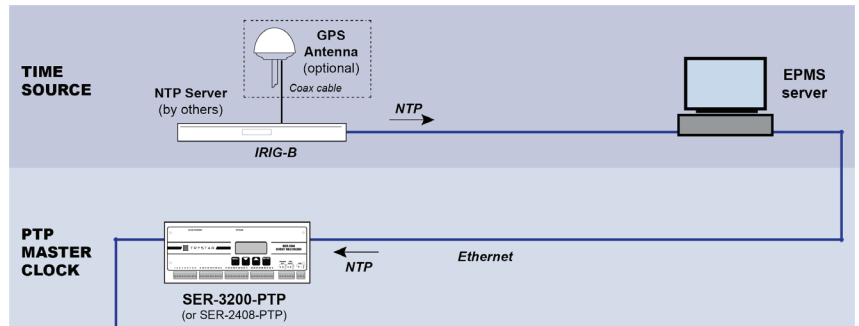

Time source: NTP server(s) located somewhere on the network (GPS antenna optional)

### Time Source: GPS Clock (IRIG-B)

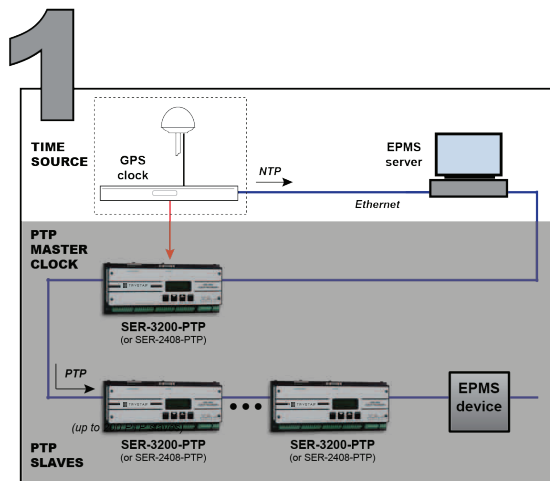

In the next example shown below, the first SER accepts a precision time sync signal (IRIG-B) from a GPS receiver/clock as its time source. The GPS clock also provides NTP time-sync for the EPMS server. This method provides greater accuracy than the previous example using NTP alone, and it also ensures a time reference traceable to a known standard reference, UTC (Coordinated Universal Time). This is useful for comparison with external data, such as outage details provided by the electric utility.

**Important:** The third-party GPS receiver/clock must output IRIG-B type DCLS, with the year included (codes B004-B007). Sometimes including the year is called “enabling IEEE 1344 extensions” referring to an older standard.

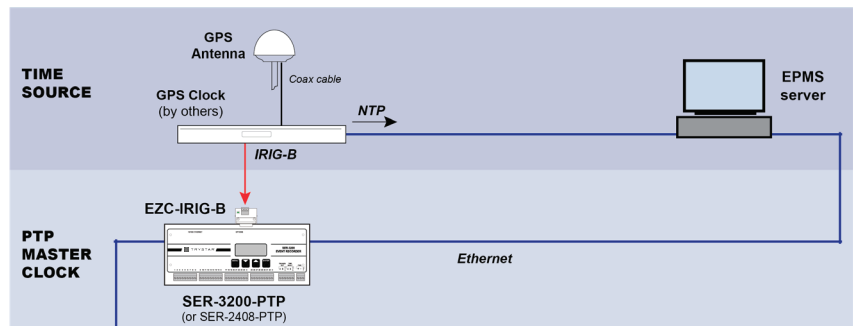

Time source: GPS receiver/clock (via IRIG-B protocol)

### Time Source: STR-100 (DCF77)

In the next example, the first SER accepts DCF77 as its time source input, from an STR-100 Satellite Time Reference by Trystar. The STR-100 is designed with industrial-grade specs, and so it can be installed in the same power equipment enclosure as the devices to be synchronized. The STR-100 uses an input signal from a Trimble Acutime 360 smart antenna (as shown), or a modulated IRIG-B signal from a GPS clock, if desired. In addition to its DCF77 output, the STR-100 can also be configured to generate “1per10” protocol (one pulse per 10 seconds), used by Sepam 20/40/80 protective relays by Schneider Electric.

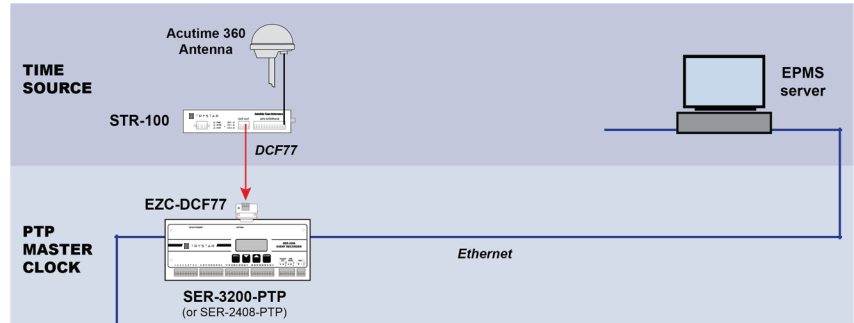

Time source: STR-100 (via DCF77 protocol)

## Time Source = GPS Clock (PTP)

### Third-party Clocks as PTP Grandmaster

For small systems (up to 10 PTP slaves), it may be possible to use a third-party GPS clock as PTP master instead of a Trystar SER. The GPS clock must be configured to use PTP options and settings compatible with the Simple PTP Profile (SPTP) used by the SERs. Normally, selecting the 1588 Default Profile is sufficient. In addition, it may be necessary to increase the grandmaster's Delay Request Interval. Consult the GPS clock manufacturer for specifications on the maximum number of PTP slaves it can support, as well as recommended adjustments to any other settings. In general, Trystar recommends using SERs as both PTP master and slave.

### Warning about Some Third-party PTP Masters

Trystar has tested its Trystar SERs (PTP slaves) with several third-party clocks as PTP masters with good results. However, some third-party clocks did not perform well when scaled up to systems with a large number of PTP slaves. Unfortunately, the current IEEE 1588 standard does not specify the number of PTP slaves that a given PTP grandmaster must support. For this reason, Trystar recommends against using third-party PTP masters unless specific testing has been done.

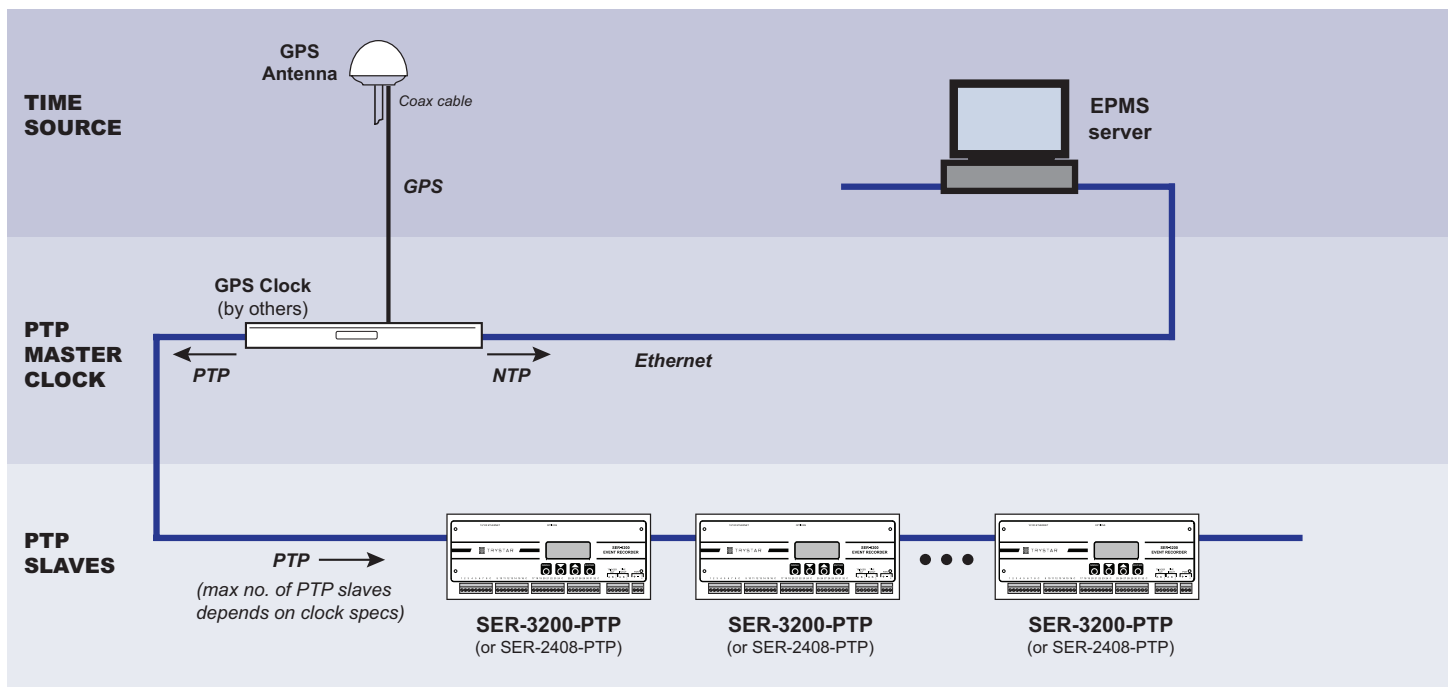

A third-party GPS receiver/clock serves as PTP master for all SERs (and other EPMS devices that support PTP)

## TIME DISTRIBUTION (PTP)

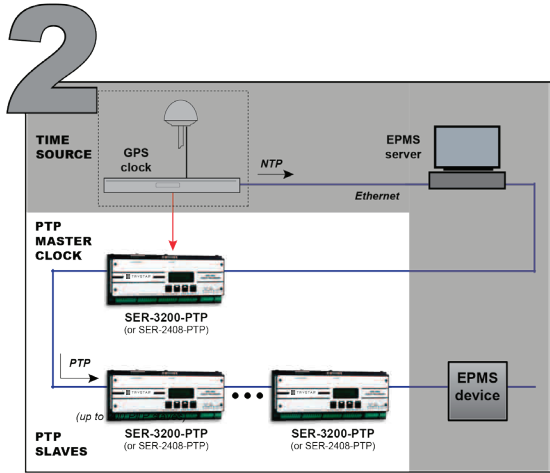

### Time-sync SERs with Each Other

Regardless of time source, all Trystar SER-3200/2408-PTP Event Recorders sync with each other over Ethernet within 100  $\mu$ sec using PTP. As shown below, configure the first SER as PTP master (grandmaster); all other SERs sync automatically using PTP over the Ethernet network. There is no need for additional setup. Unlike NTP, in which each NTP client must be configured with one or more NTP server IP addresses, PTP slaves automatically sync to the PTP grandmaster.

Trystar SERs do have a user-configurable setting for "PTP Domain;" however, this is normally left at its default value of zero, unless multiple PTP sub-systems are desired for very large systems. (See later section on scalability.)

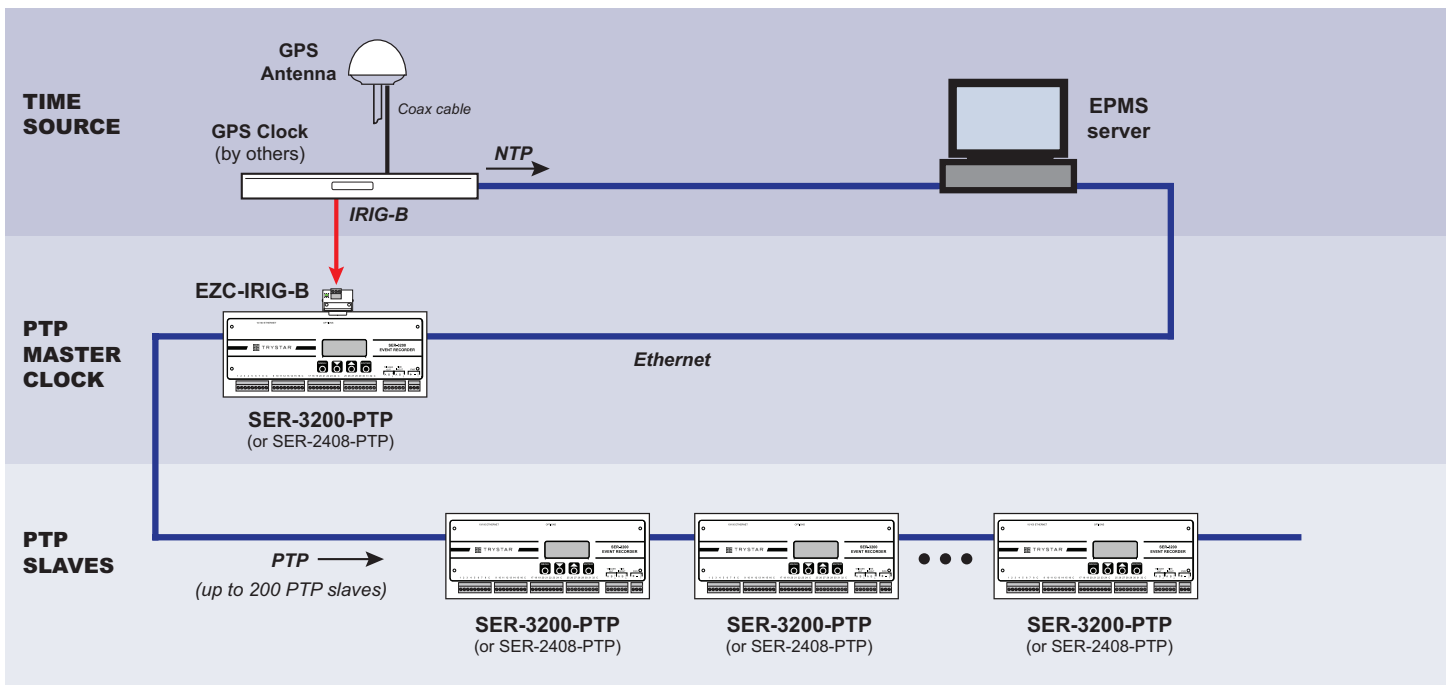

Sync the first Trystar SER (in this example, using IRIG-B), and all other SERs sync automatically using PTP

## SYNCHRONIZING NON-PTP DEVICES

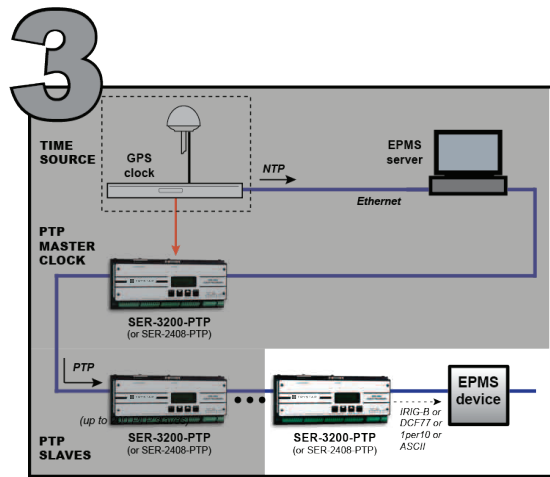

### Sync all EPMS Devices via PTP

Extend time synchronization to other EPMS devices (relays, meters, PLCs, etc.) by setting these to use the IEEE 1588 PTP Default Profile (End to End). PTP-compatible devices will sync automatically to the first Trystar SER serving as PTP grandmaster. No need to specify IP address of the PTP master—PTP systems are self-organizing.

### No PTP? No Problem

Need precision sync to devices that don't support PTP? No problem. The type of device to be synchronized usually dictates the choice of time-sync protocol, since supported protocols vary by manufacturer and type. Fortunately, Trystar SERs offer ways to integrate these devices by accepting PTP to sync its clock to that of the PTP master, then output date/time using the legacy protocol(s) required, effectively making them "PTP-enabled," too. Some factory wiring is needed, but the cost and complexity of field wiring between lineups is eliminated.

The supported legacy protocols for time-sync output by a Trystar SER are:

- IRIG-B (Unmodulated)
- DCF77
- 1per10
- ASCII serial time code (over RS-485)

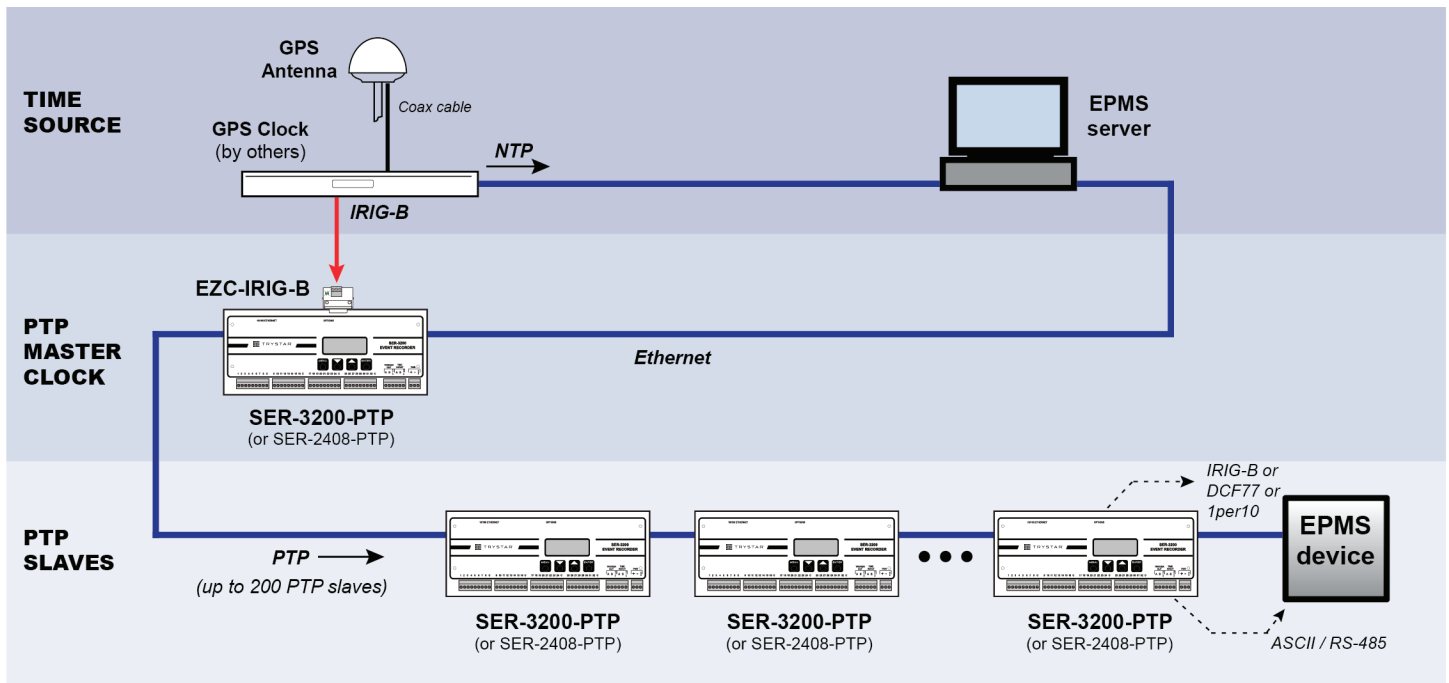

The first Trystar SER serves as PTP master and sync all other SERs (PTP slaves); each PTP slave then outputs the legacy protocol needed to sync one or more EPMS devices, making them effectively "PTP-enabled"

# SYNCHRONIZING NON-PTP DEVICES (via IRIG-B)

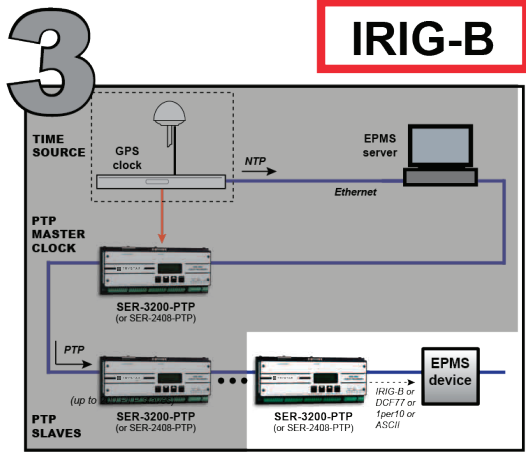

The IRIG time codes were originally developed by the US military and are widely used by electric utilities for time synchronization. The IRIG-B time code consists of 100 pulses per second and transmits a complete date/time every second, although the year may or may not be included.

The two most common variations used in power system applications:

- Unmodulated IRIG-B, DC Level Shift (DCLS)
- Modulated IRIG-B (1kHz carrier)

The IRIG 200-04 standard does not define specific signal levels, but both IRIG-B types are typically distributed at TTL levels (5 Vdc) via point-to-point wiring, either via coaxial or shielded, twisted-pair cable. This may be suitable for a small number of devices over short distances. To synchronize a larger number of devices, a daisy-chain topology is often preferred, using twisted-pair cabling rather than coax. However, at 5 Vdc, distances and number of devices are limited.

For more information on IRIG-B, see Tech Note: IRIG-B Time Codes (TN-102)

### Time-synch Output: Unmodulated IRIG-B (< 8 devices)

A Trystar SER (with PTP enabled) can be configured to output the most common form of IRIG-B: unmodulated, or DC Level Shift (DCLS) at 5 Vdc nominal. A PTP Legacy Interface (PLX-5V) connected to the SER DB-15 port outputs the signal at 5 Vdc nominal. This IRIG-B time code supports the full date/time, including the year (IRIG code “B006”), and is compatible with most meters and relays that support IRIG-B.

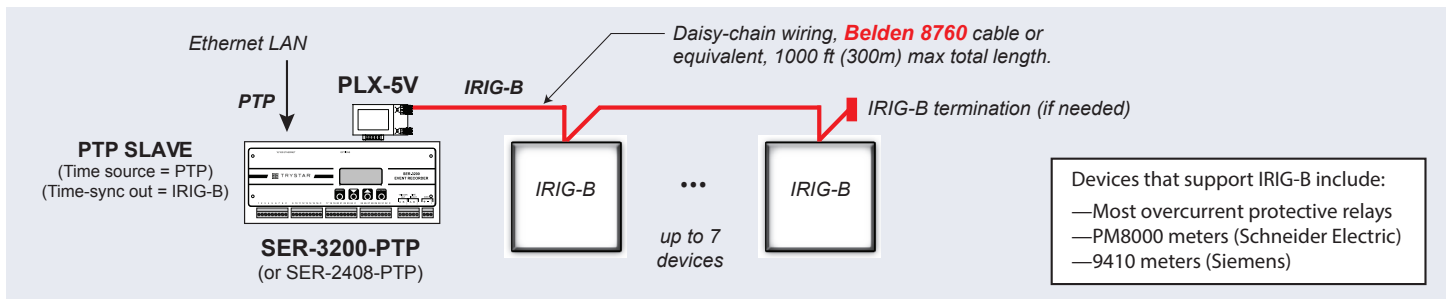

### Time-synch Output: Unmodulated IRIG-B (8 or more devices)

For reliable distribution over longer distances or to a greater number of devices, this same IRIG-B code can be output at 24 Vdc using a PLX-24V accessory instead. This signal is then distributed (with 24 Vdc control power) via a multi-point connection to “IRIG-B Distribution Modules” (IDM) which in turn convert the signal back to the expected 5 Vdc for point-to-point connection to up to eight (8) IRIG-B devices.

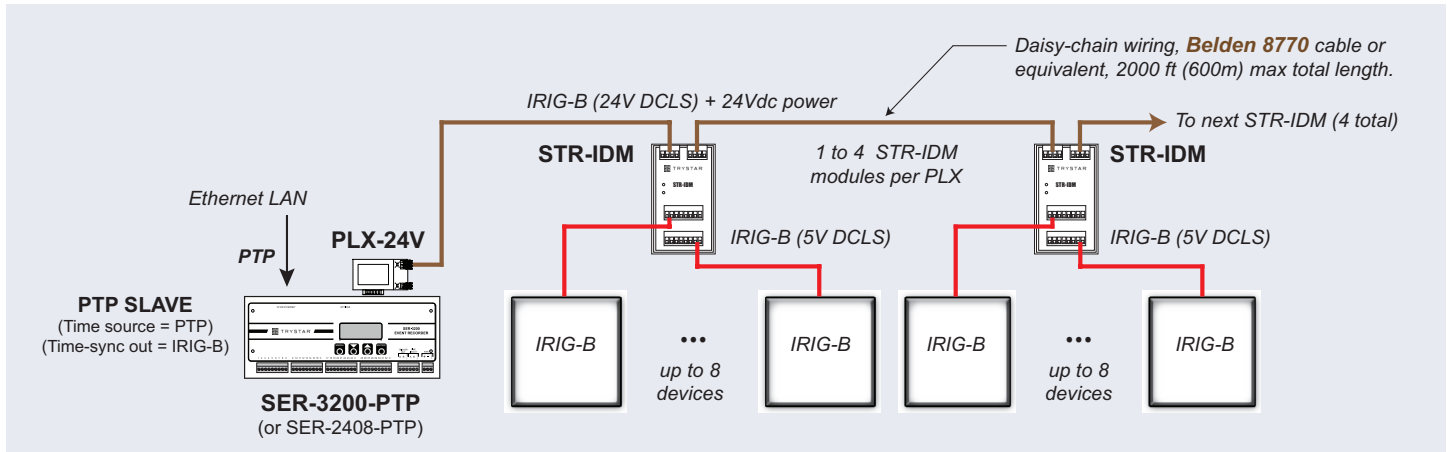

## SYNCHRONIZING NON-PTP DEVICES (via DCF77)

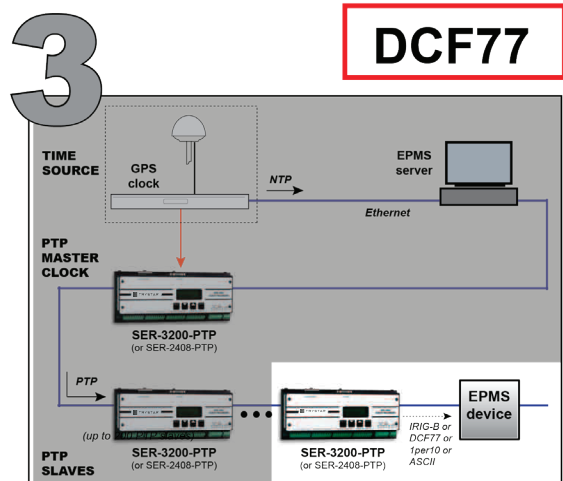

### Time-sync Output: DCF77

DCF77 is a time protocol similar to IRIG-B with equivalent accuracy but distributed at 24 Vdc via multi-point wiring. DCF77 has one pulse per second (1 PPS) and transmits a complete date/time every minute, including the year.

A Trystar SER (with PTP enabled) can be configured to output the standard DCF77 signal (24 Vdc) via a PTP Legacy Interface (PLX-24V). Generally, the choice to support DCF77 is dictated by the device(s) that require this method for time sync. This protocol is most commonly used by PowerLogic™ CM4000 series meters from Schneider Electric and Power Xpert™ PXM 4000/6000/8000 meters from Eaton.

For more information on DCF77, see **Tech Note: DCF77 Time Protocol (TN-103)**

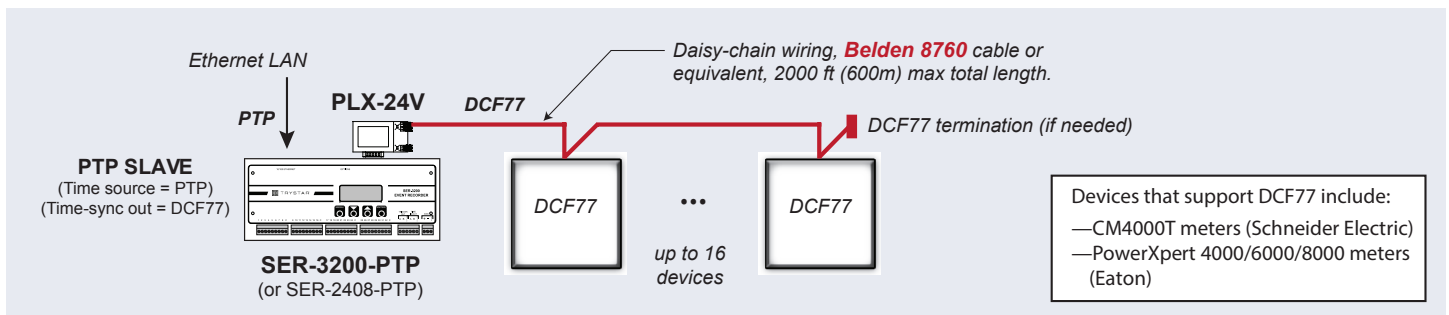

## SYNCHRONIZING NON-PTP DEVICES (via 1per10)

### Time-sync Output: 1per10

Another protocol supported by Trystar SERs is called 1per10 (one pulse every 10 seconds). This method requires that the device clock first be set to the approximate date/time (within 4 seconds of the correct time). Thereafter, the sync pulse is simply used to adjust the device clock precisely and maintain synchronization to a master.

The PTP Legacy Interface PLX-24V is also used to output 1per10 (at 24 Vdc). The 1per10 output is set via the SER-3200/2408-PTP Time Setup web page. 1per10 is used by Sepam 20/40/80 protective relays from Schneider Electric.

For more information on 1per10 protocol and its application with Sepam relays, see *Tech Note: 1per10 Time Protocol (TN-104)*.

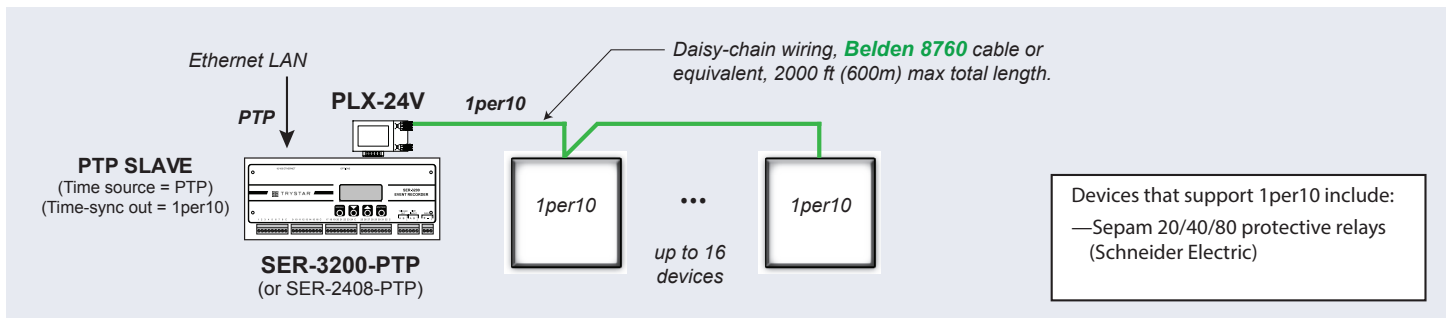

## SYNCHRONIZING NON-PTP DEVICES (via ASCII/RS-485)

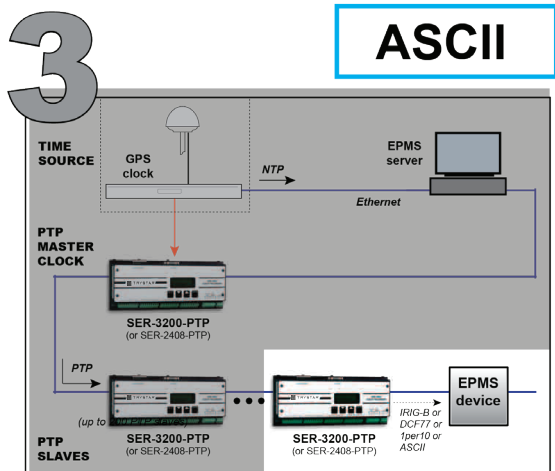

### Time-sync Output (ASCII / RS-485)

The Trystar SER-3200/2408 (all models) has a built-in RS-485 communications port that can be used to output the ASCII serial code required by some power meters, such as PM8000 and ION 7550/7650 meters from Schneider Electric and 9410 and 9510/9610 meters from Siemens.

These meters use a proprietary ASCII protocol (“ASCII + Quality”) originally defined by Arbiter systems, and is typically distributed over a 2-wire RS-485 network at 9600 bps. The SER is configured to accept PTP as its time source and enabled as time-sync master, to generate ASCII RS-485 output to one or more devices. In most cases, one SER will sync one meter, making it easier to treat the two as one logical device. If desired, up to 16 devices can be synchronized over RS-485 from a single SER.

For greater flexibility, a Trystar SER configured as PTP master (outputs PTP to other devices) also outputs ASCII/RS-485 by default. (See note below.)

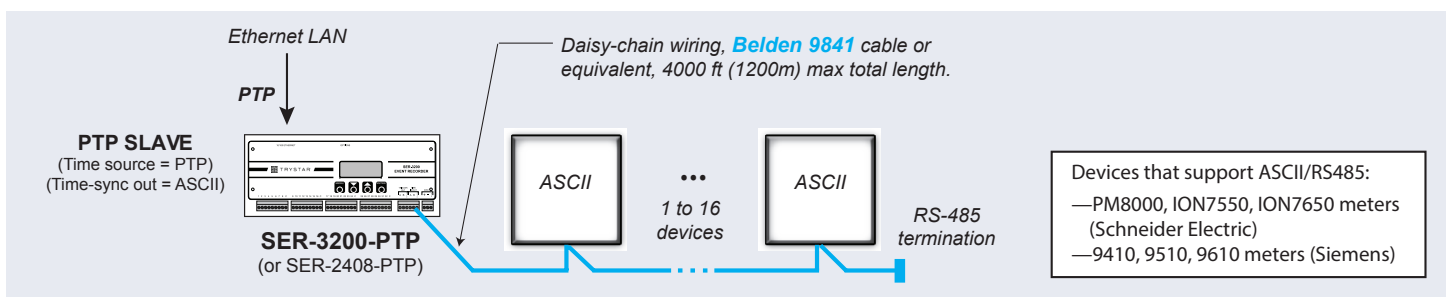

## SYNCHRONIZING NON-PTP DEVICES (ASCII hybrid systems)

**Note:** Only one protocol can be selected for output via the PLX connector (IRIG-B, DCF77 or 1per10). However, for maximum flexibility, the ASCII / RS-485 output is enabled by default any time an SER is set to use PTP for time source (IN) or time-sync (OUT).

### Time-sync Output (ASCII / RS-485) + IRIG-B

Because the RS-485 comm port is built into the SER-3200/2408-PTP models, it is possible to output both ASCII/RS-485 and another protocol (e.g., IRIG-B) out its top DB-15 connector using a PLX interface.

Note: Only one protocol can be selected for output via the PLX connector (IRIG-B, DCF77 or 1per10). However, for maximum flexibility, the ASCII / RS-485 output is enabled by default any time an SER is configured with time source = PTP. Thus, an SER can output one of these protocols (via the PLX connector) and output the ASCII/ RS-485 signal as well, without additional configuration for the ASCII output.

The example shown below illustrates such a case, with conventional (5V) IRIG-B signal via PLX-5V and ASCII via the RS-485 time-sync output connection.

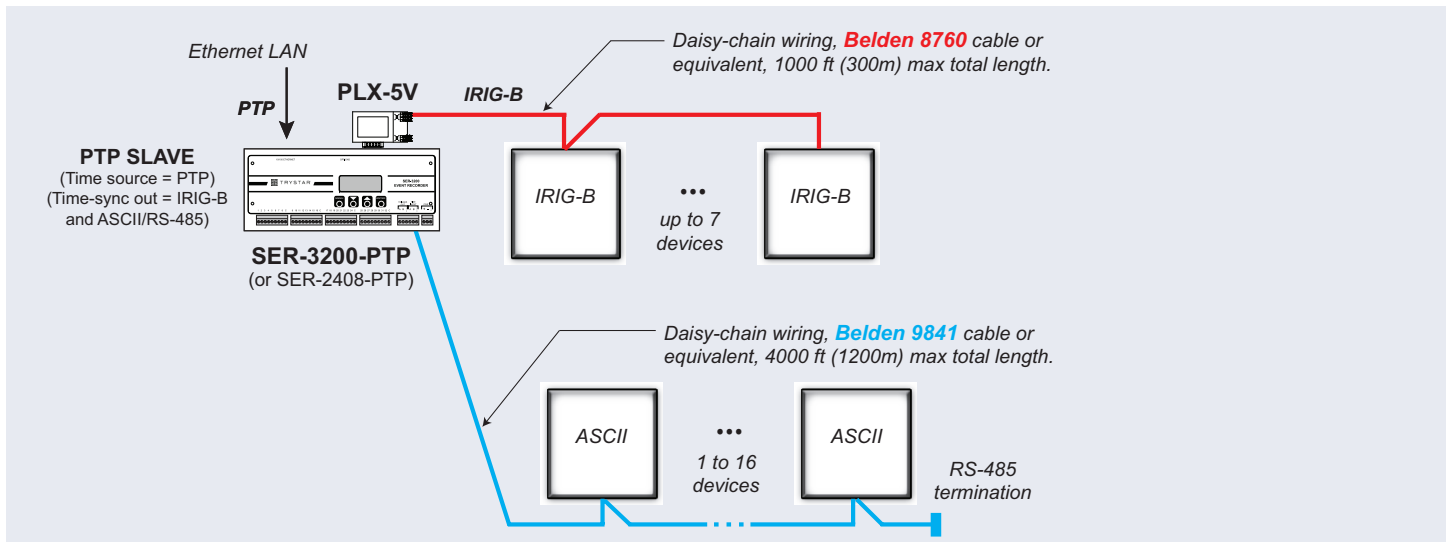

# REDUNDANT TIME MASTERS (IRIG-B input to master plus standby)

## GPS Clock as Time Source (IRIG-B) PLUS Backup PTP Master

As stated previously, PTP clocks are self-organizing, in that they establish a hierarchy of interconnections based on messages exchanged. Slaves automatically sync to the master (grandmaster). A second, redundant (optional) grandmaster-capable clock can stand by in passive mode and function as grandmaster if the first is unavailable. In the example below, the first two SERs accept IRIG-B as time source (from a thirdparty clock); the first SER serves as PTP master (grandmaster) and the second SER remains in passive (standby) mode.

In addition to providing a backup to the primary PTP master to increase system reliability, this architecture also provides a built-in path for scalability in case it is needed in future expansions. This is explained in the next section.

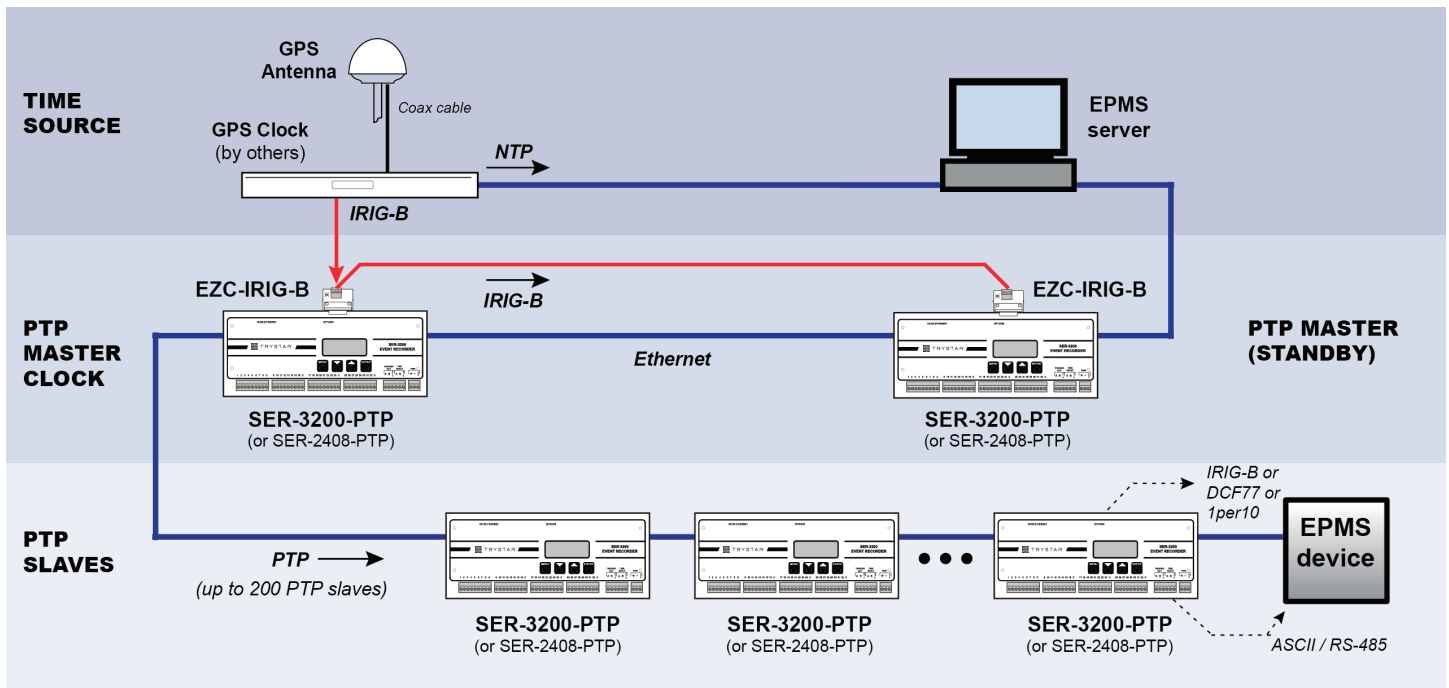

PTP time sync system: two SERs accept IRIG-B time sync (from third-party clock), one serves as PTP master for all other SERs; the other is standby master

# SCALABILITY

## PTP Scalability

Trystar Event Recorders have been tested under real-world network conditions and are proven to maintain hi-resolution time in large systems with over two hundred devices. Much larger systems are expected to function satisfactorily, but if extreme network conditions prove otherwise, there is a simple solution. Instead of bringing IRIG-B or DCF77 to just one SER serving as a single grandmaster, the same time signal can be connected to a second SER to serve as a second grandmaster, using a different domain number. Half of the slave devices would simply be set to this second domain number, resulting in two logical PTP systems, independent of each other. In this way, PTP is scalable for virtually any size project, and greatly simplifies building out a system in phases.

Note that the drawing below which illustrates scaling up a PTP time-sync system is nearly identical to the previous example with a redundant SER as backup PTP grandmaster. The physical connections are the same; the system is simply reconfigured to use multiple PTP domains (settings change only).

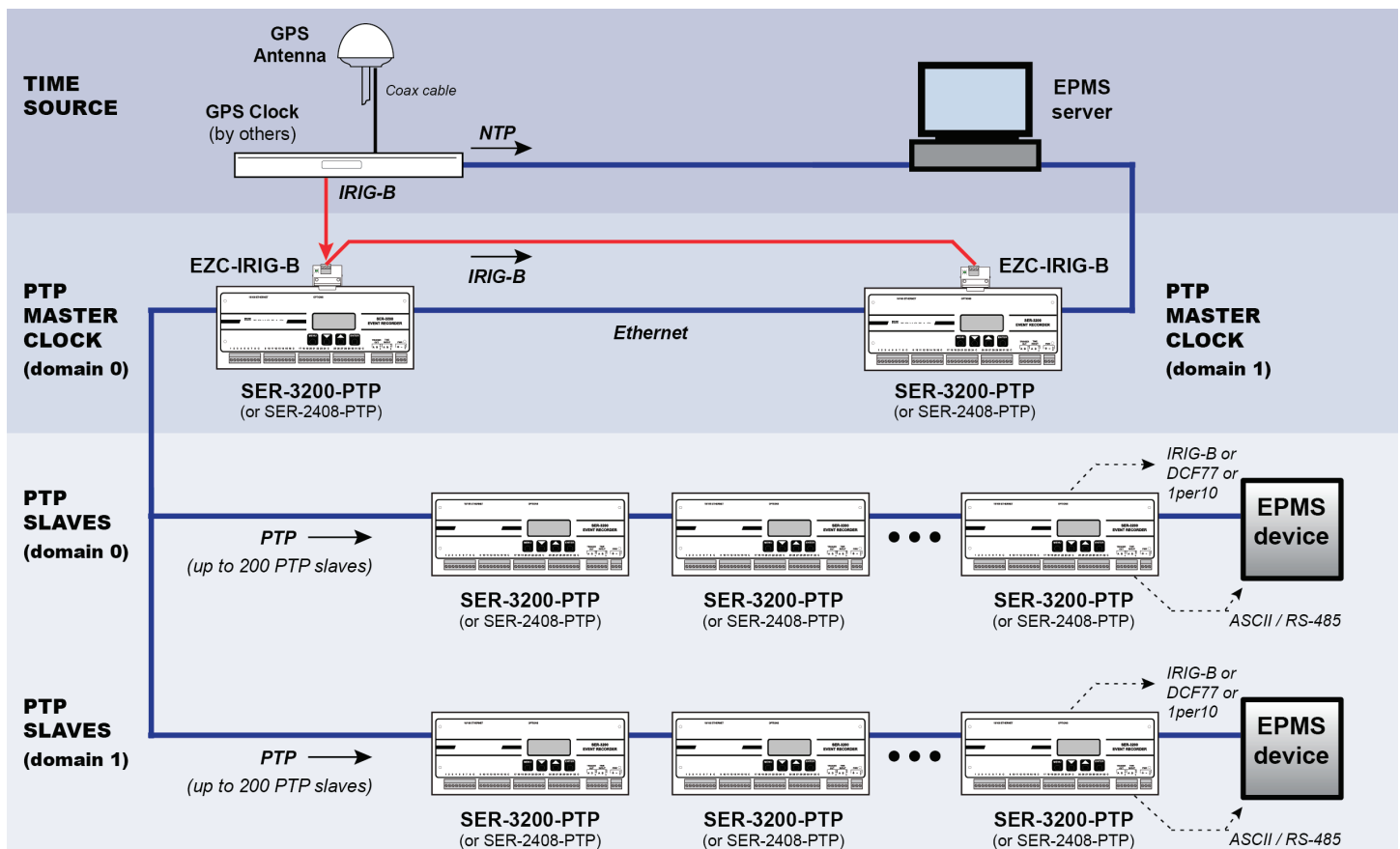

PTP time sync system: two SERs accept IRIG-B time sync (from third-party clock), one serves as PTP master for SERs on PTP domain 0; the second serves as PTP master for SERs on PTP domain 1. This allows the system to scale up easily as additional devices (PTP slaves) are added.

## EPMS SYSTEM EXAMPLE 1

### (Set first SER via Modbus TCP)

The first EPMS system architecture example is illustrated below.

**Time Source.** The first Trystar SER-3200 (or SER-2408) is set over the Ethernet network by the EPMS (or other supervisory) server, using the SER's Modbus TCP command interface. The EPMS server and first SER clock may differ by up to one second; however, all other devices are synchronized more precisely with each other.

**Time Distribution.** The first SER serves as PTP grandmaster for all other Trystar SERs (PTP slaves), synchronized within 100 µsec of each other.

**Time Conversion.** If other EPMS devices do not yet support PTP, then a nearby SER can also be used as a "time-sync hub" to output the legacy protocol needed. For illustration purposes, protective relays and meters are shown which require different time protocols, along with a nearby SER which outputs the protocol needed:

- MV (medium voltage) switchgear: relays use IRIG-B and meters use ASCII/RS-485.
- Generator switchgear: relays use IRIG-B and meters use ASCII/RS-485.
- LV (low voltage) switchgear or switchboards: meters shown use IRIG-B.
- PDP (power distribution panel): meters shown use DCF77.
- UPS cabinets: meters shown use ASCII/RS-485.

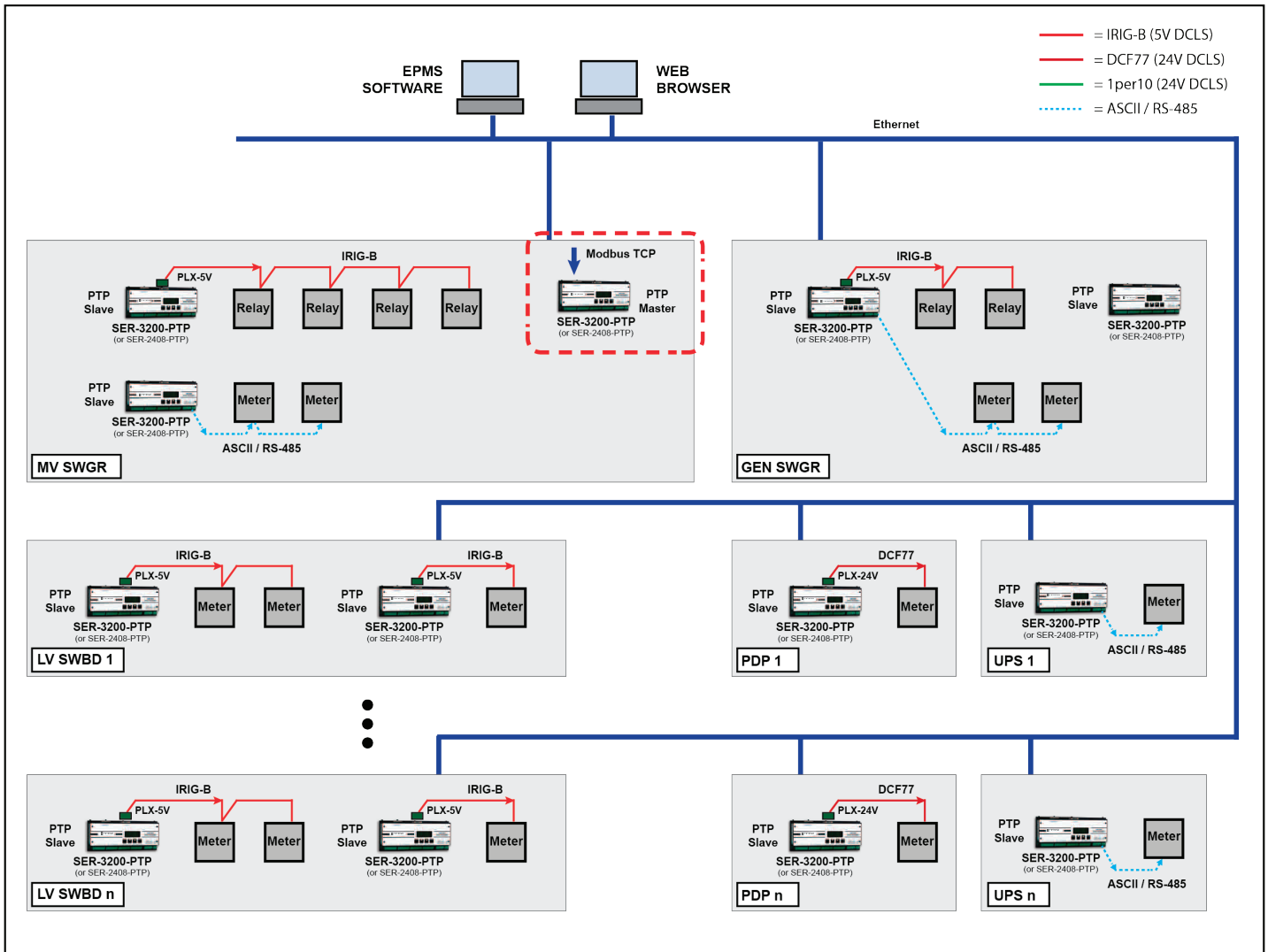

EPMS SYSTEM EXAMPLE 1—High-def time-sync over Ethernet using PTP, first SER is set by an EPMS server using Modbus TCP

## EPMS SYSTEM EXAMPLE 2 (Sync first SER to NTP server)

A second PTP-enabled system example is illustrated below.

**Time Source.** The first Trystar SER-3200 (or SER-2408) syncs to an NTP server located somewhere on the same Ethernet network.

**Time Distribution.** As in the previous example, the first SER then serves as PTP grandmaster for all other Trystar SERs (PTP slaves), synchronized to 100  $\mu$ sec.

**Time Conversion.** Again, for illustration purposes, protective relays and meters are shown which require different time protocols. A nearby SER serves as a “PTP timesync hub” to output the legacy protocol needed.

Note: if EPMS devices all support the same protocol (e.g., IRIG-B), then the method shown for IRIG-B devices in one type of equipment would also be used in the other equipment types. The combinations shown below are chosen to illustrate many alternatives, not to imply that a typical system includes all possible protocols.

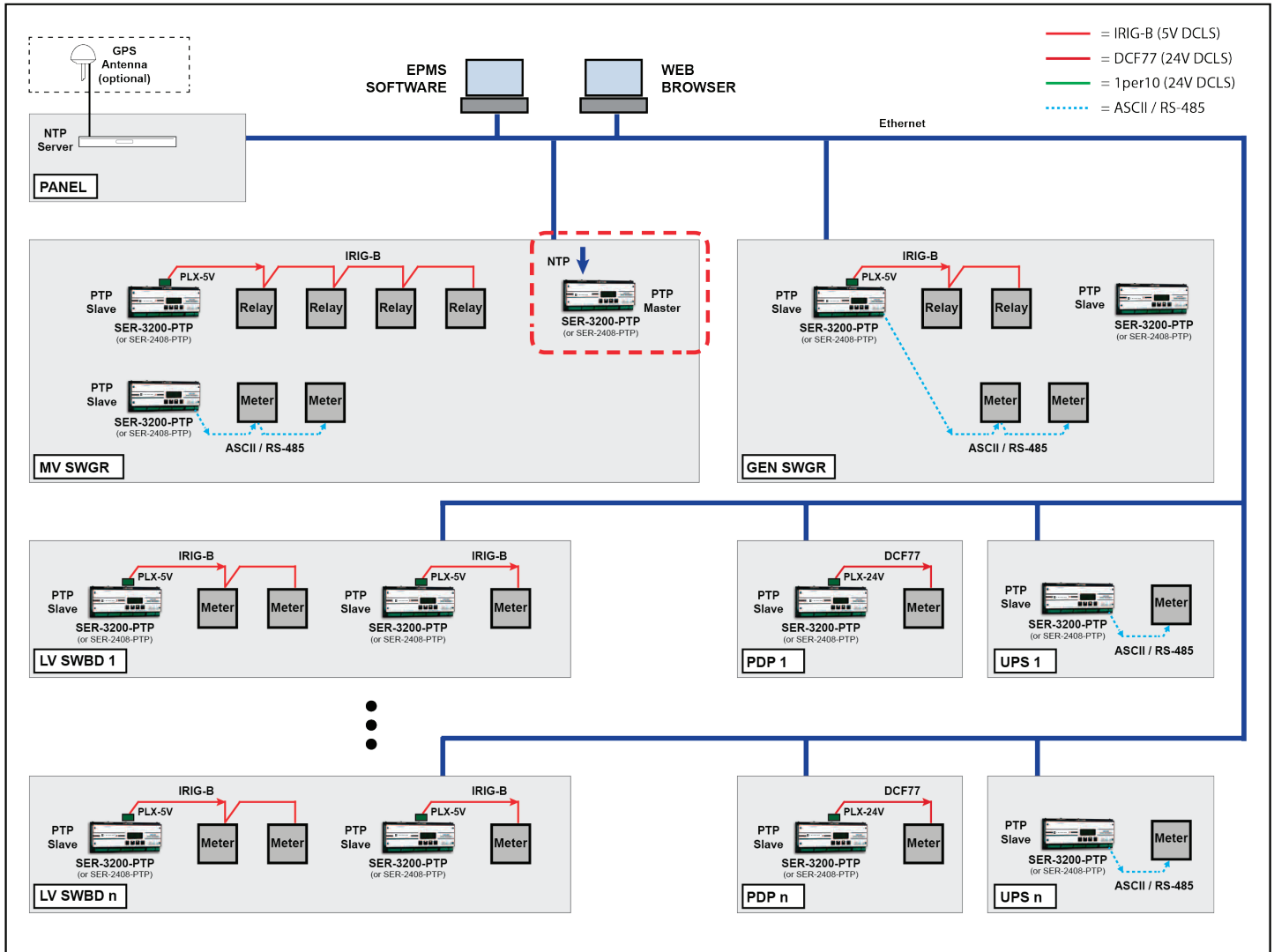

EPMS SYSTEM EXAMPLE 2—High-def time-sync over Ethernet using PTP, first SER syncs to a network time server (NTP), GPS optional

### EPMS SYSTEM EXAMPLE 3 (NTP server, first SER in same panel)

System example 3 is a variation of the previous example.

**Time Source.** Again, the first Trystar SER is synchronized to an NTP server, but this time this first SER is located in the same panel as the NTP server (or another EPMS control panel, but not in the first power equipment enclosure).

**Time Distribution and Conversion.** All other details are the same: all SERs are synchronized with each other automatically over Ethernet using PTP, and various SERs also serve as local time-sync hubs for devices that do not support PTP directly.

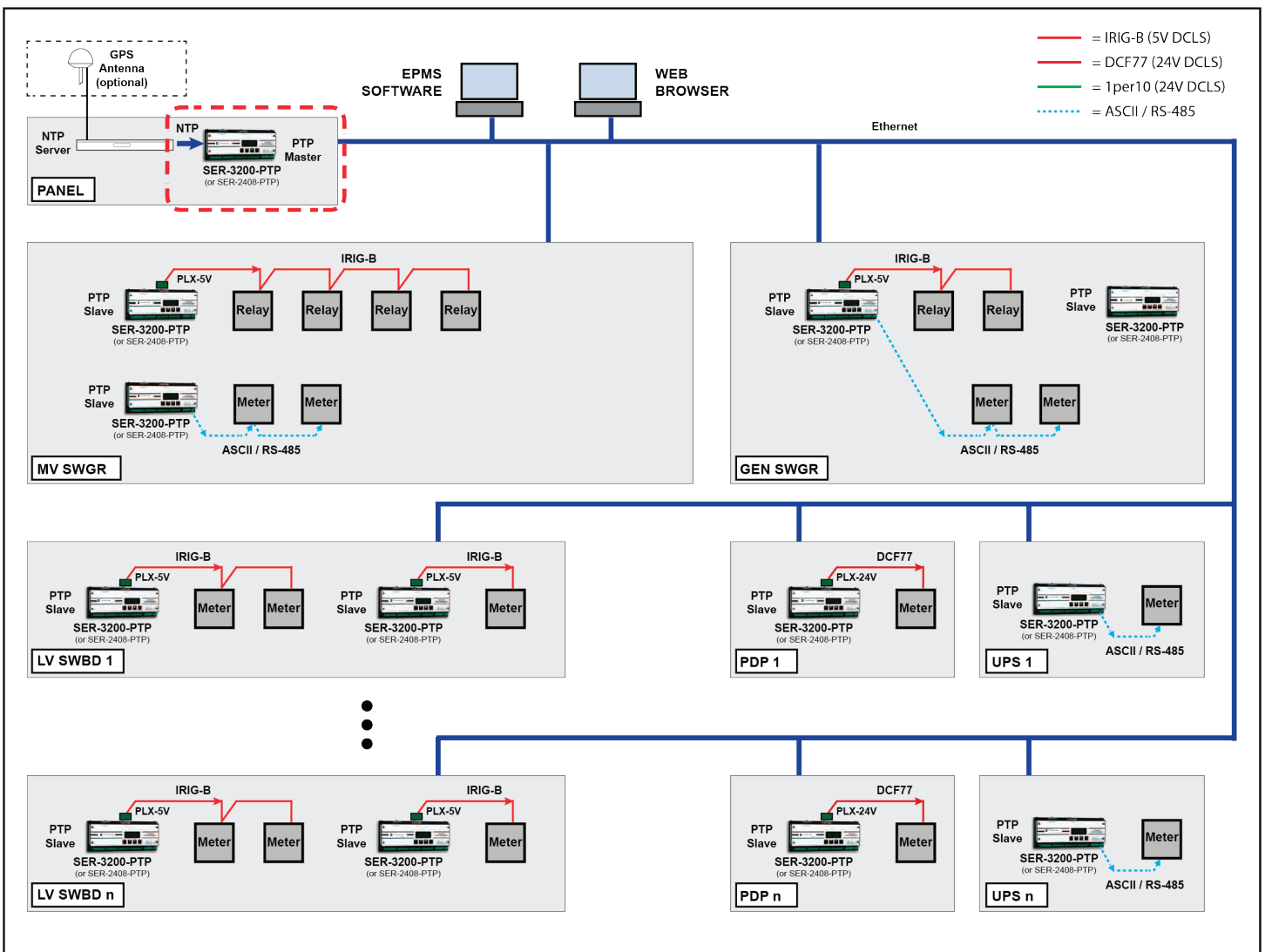

EPMS SYSTEM EXAMPLE 3—High-def time-sync over Ethernet using PTP; first SER is in same panel as NTP server

# EPMS SYSTEM EXAMPLE 4 (IRIG-B, first SER in same panel)

System example 4 is identical to example 3, except:

**Time Source.** The first Trystar SER (located in the same panel as the GPS clock) gets its time source from the clock via IRIG-B, not NTP. This improves the relative accuracy to the UTC time reference, as compared with using NTP as its time source.

**Time Distribution and Conversion.** The remainder of the example is unchanged from example 4. The protective relays are assumed to support IRIG-B, and so a PTP slave SER device outputs this signal to the relays. Likewise, all the other relays and meters are shown using the time-sync protocols they support.

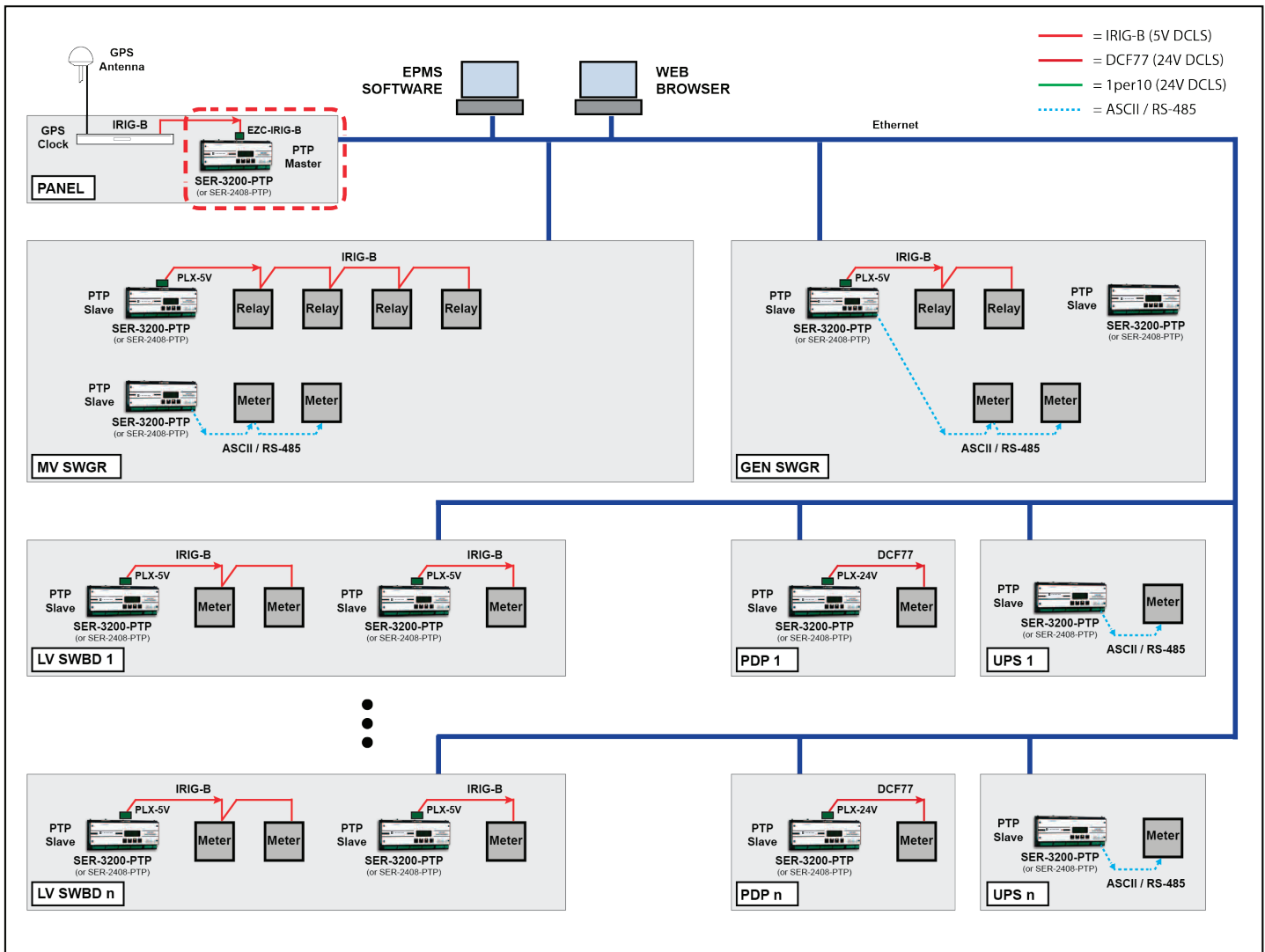

EPMS SYSTEM EXAMPLE 4—High-def time-sync over Ethernet using PTP; first SER is in same panel as GPS clock (IRIG-B time source)

## EPMS SYSTEM EXAMPLE 5

### (Sync first SER via IRIG-B, GPS clock)

The next example is a variation on the design in the previous example 4.

**Time Source.** The first Trystar SER is located in the MV switchgear and accepts IRIG-B as its time source from a GPS clock.

**Time Distribution (IRIG-B).** Most protective relays also support IRIG-B time sync, and so the same IRIG-B signal is daisy-chained to sync the relays, as well. If the number of relays exceeds the number of devices the clock can support with one IRIG-B channel, then a second IRIG-B output may be needed.

**Time Distribution (PTP).** The first SER serves as PTP grandmaster for all other Trystar SERs (PTP slaves), synchronized within 100  $\mu$ sec of each other.

**Time Distribution (NTP)** The GPS clock may also be equipped with an NTP server option to sync devices which can accept NTP but do not support a precision time protocol, such as the EPMS server.

**Time Conversion.** As in previous examples, the devices located in other power distribution equipment enclosures are synchronized from a nearby SER, using the protocol needed.

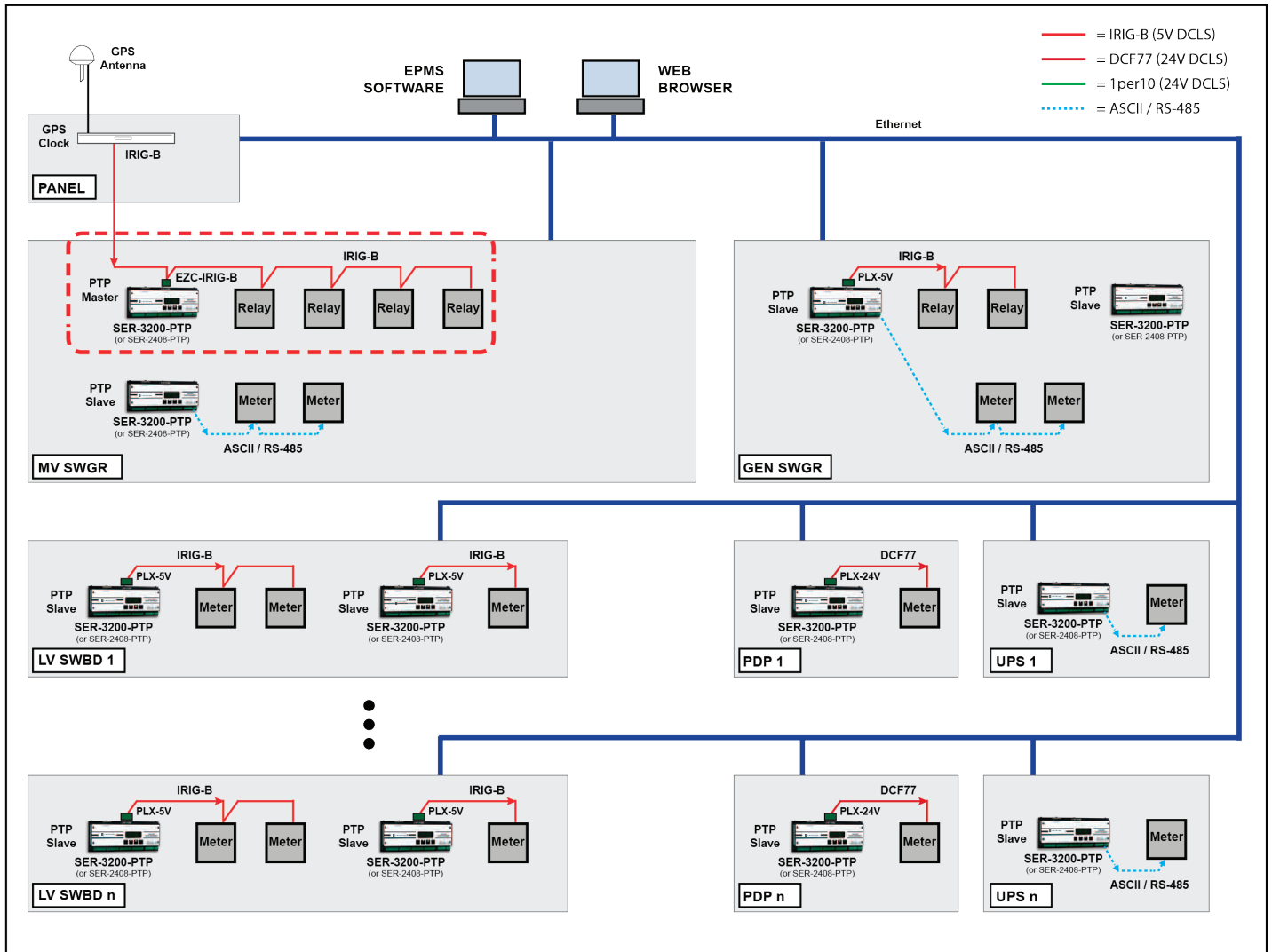

EPMS SYSTEM EXAMPLE 5—High-def time-sync over Ethernet using PTP; first SER is in MV switchgear (IRIG-B time source from GPS clock)

## EPMS SYSTEM EXAMPLE 6

(Sync 2 or more SERs via IRIG-B:

PTP Master and PTP Standby Master)

### RECOMMENDED SOLUTION

Example 6 shown below takes the system architecture of Example 5 one important step further.

**Time Source.** In addition to the first SER, a second Trystar SER also accepts IRIG-B as its time source from the GPS clock. In this design, both SERs are configured as a PTP master using the same PTP domain number. Using the IEEE 1588 “Best Master Clock” algorithm, one SER automatically acts as the PTP grandmaster clock, and the other waits in standby mode in case it is ever needed as a backup.

**Time Distribution.** The first SER (or the backup SER) serves as PTP grandmaster for all other Trystar SERs (PTP slaves), synchronized within 100  $\mu$ sec of each other. If the first clock fails or goes offline, the backup PTP master becomes the grandmaster clock automatically and remains in service until the other is restored. This ensures reliable, uninterrupted time service to all devices.

**Time Conversion.** As in previous examples, the devices located in other power distribution equipment enclosures are synchronized from a nearby SER, using the protocol needed.

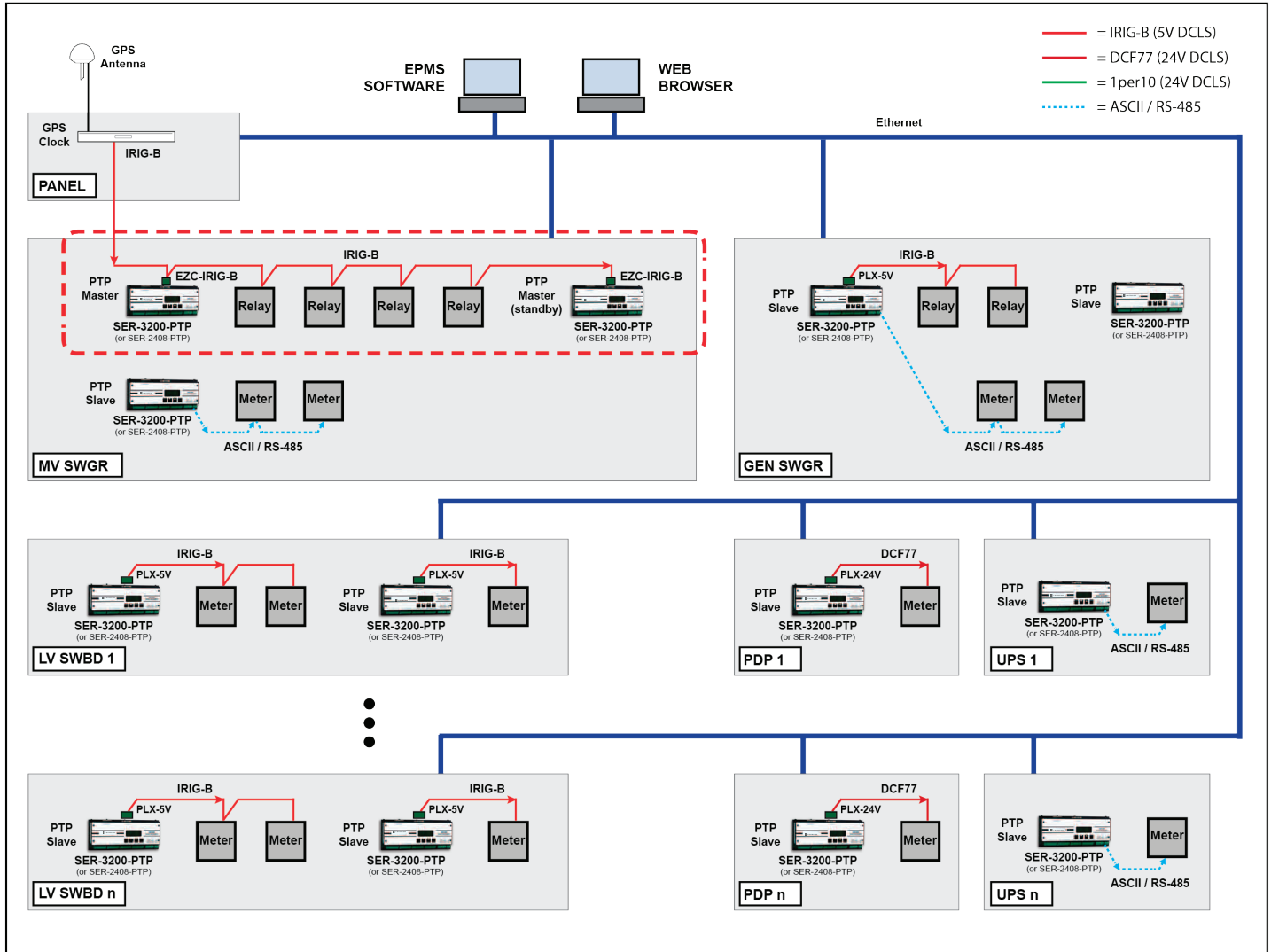

EPMS SYSTEM EXAMPLE 6—High-def time-sync over Ethernet using PTP; two SERs accept IRIG-B from GPS clock, one is PTP master, other is standby

## EPMS SYSTEM EXAMPLE 7

### (Sync first SER via IRIG-B, relays via 1per10)

Example 7 uses the same time source as Example 4; however, in this example, the protective relays in the MV switchgear do not support PTP or IRIG-B; instead, they require 1per10 protocol (e.g., Sepam 20/40/80 relays from Schneider Electric).

**Time Source.** The first Trystar SER (PTP master) is located in the same panel as the GPS clock and accepts IRIG-B as its precision time source.

**Time Distribution (PTP).** The first SER serves as PTP grandmaster for all other Trystar SERs (PTP slaves), synchronized within 100  $\mu$ sec of each other.

**Time Conversion.** Conveniently, the Trystar SER located in the MV switchgear (PTP slave) also outputs 1per10 to the protective relays. Redundant cabling between the GPS clock's enclosure and the MV switchgear is avoided. This is especially crucial if the MV switchgear is outdoors or in a different building than the control panel.

The examples for time sync of other EPMS devices (via IRIG-B, DCF77 or ASCII) are the same as all the previous examples.

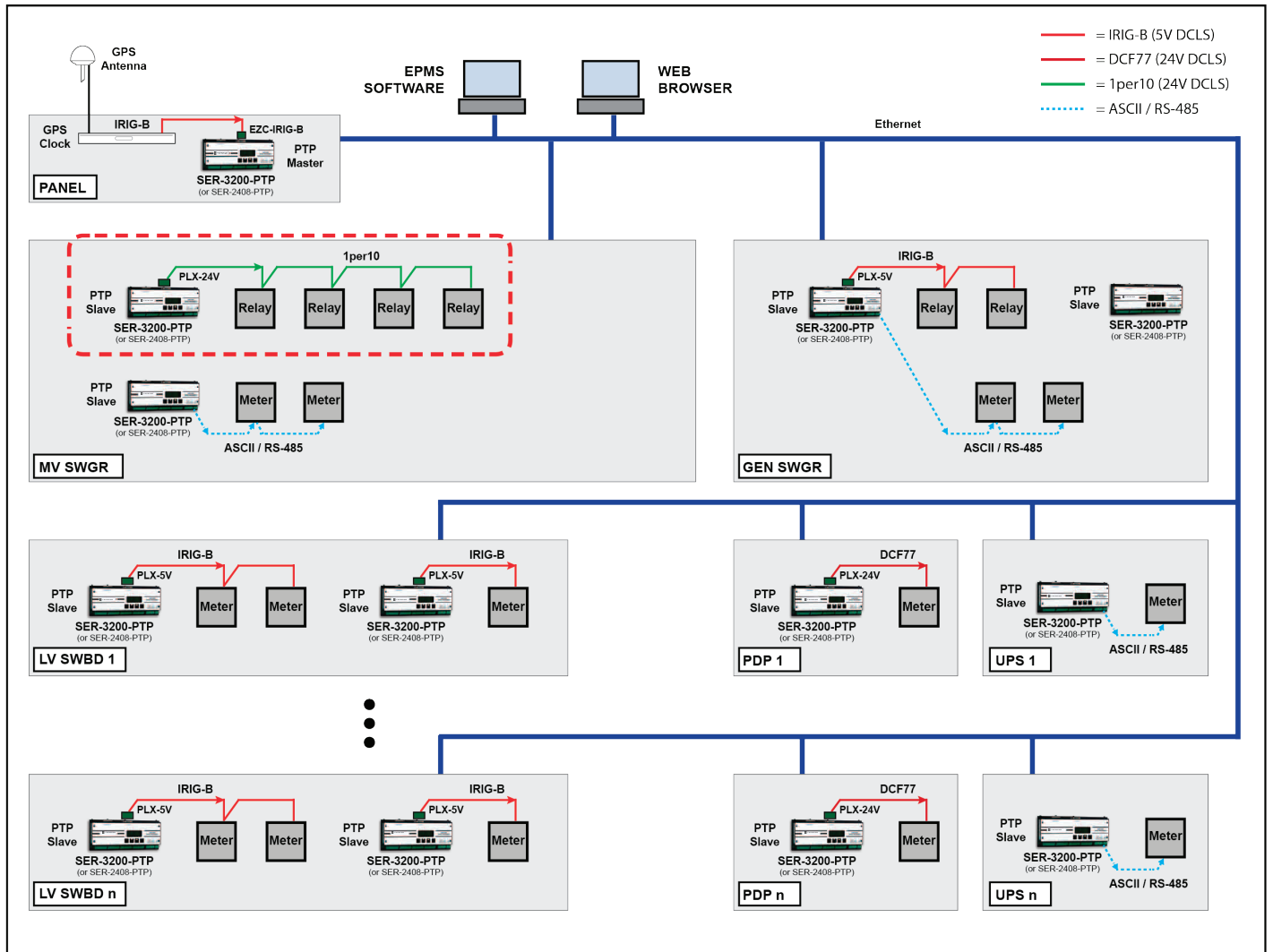

EPMS SYSTEM EXAMPLE 7—High-def time-sync over Ethernet using PTP; first SER is in same panel as GPS clock (IRIG-B time source); relays use 1per10

## EPMS SYSTEM EXAMPLE 8 (Sync first SER sync via DCF77)

Example 8 shows an alternate solution for providing the 1per10 time protocol required by some protective relays in the MV switchgear (e.g., Sepam 20/40/80 relays from Schneider Electric).

**Time Source.** An STR-100 Satellite Time Reference (by Trystar) outputs 1per10 to the protective relays. The STR-100 industrial-grade specs allow it to be mounted directly into the MV switchgear, typically in its instrument compartment. The STR-100 accepts a GPS input from a Trimble Acutime 360 smart antenna.

The STR-100 also outputs a DCF77 time signal to one or more Trystar SERs. This provides flexibility to configure one or more SERs as a standby PTP master clock, similar to the example described in Example 6.

**Time Distribution.** The first SER serves as PTP grandmaster for all other Trystar SERs (PTP slaves), same as previous examples.

**Time Conversion.** The examples for time sync of other EPMS devices (via IRIG-B, DCF77 or ASCII) are the same as previous examples.

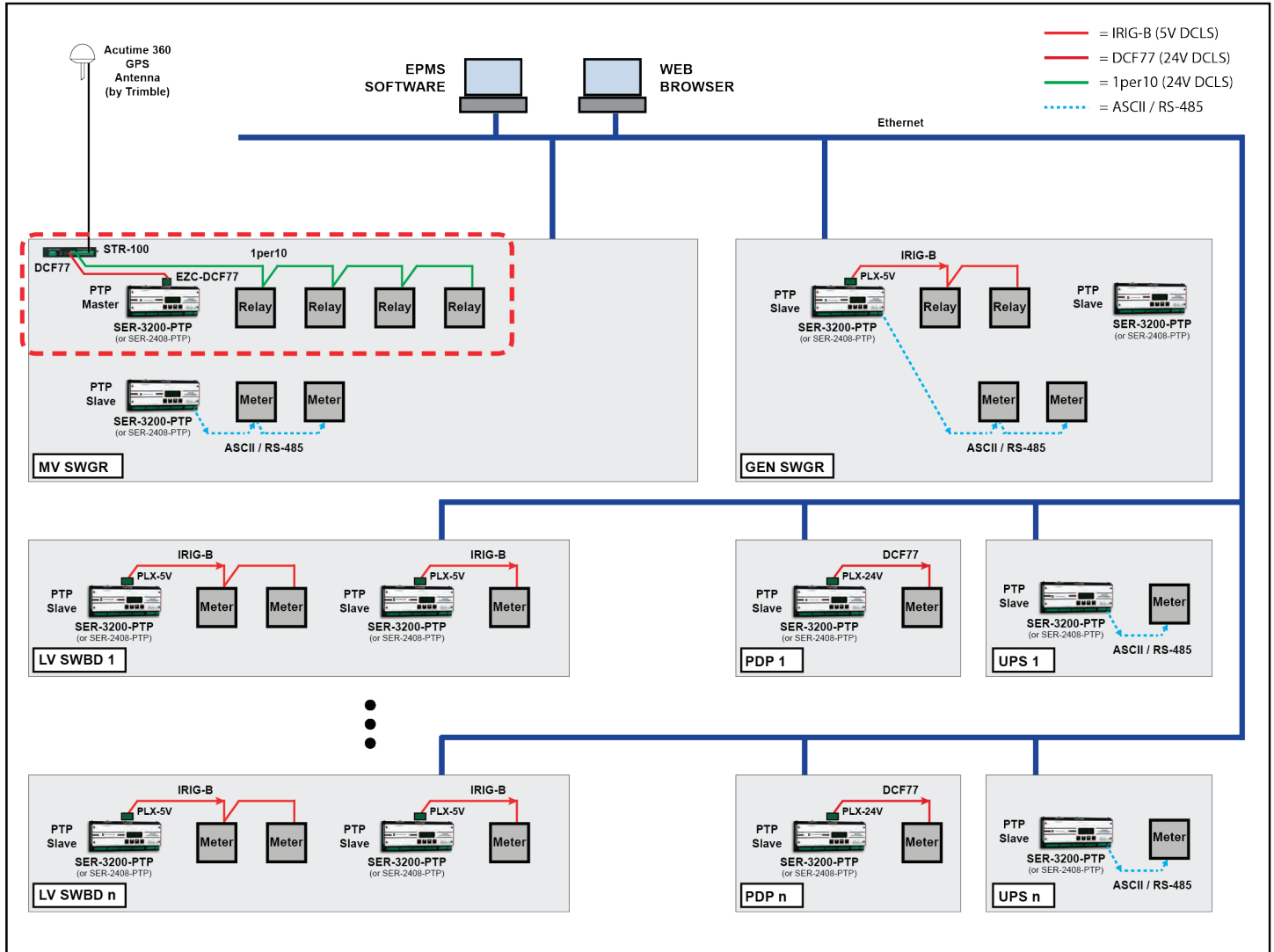

EPMS SYSTEM EXAMPLE 8—High-def time-sync over Ethernet using PTP; STR-100 outputs DCF77 to first SER, 1per10 to protective relays

# LEGACY SYSTEM ARCHITECTURES

## SYSTEM L1—All DCF77 Devices

These “Legacy System Architectures” are provided for reference to support older systems without PTP.

The STR-100 Satellite Time Reference accepts an input from a Trimble Acutime 360 smart antenna (or modulated IRIG-B from a conventional clock) and outputs two DCF77 output channels, each of which can sync up to 16 devices, as shown below.

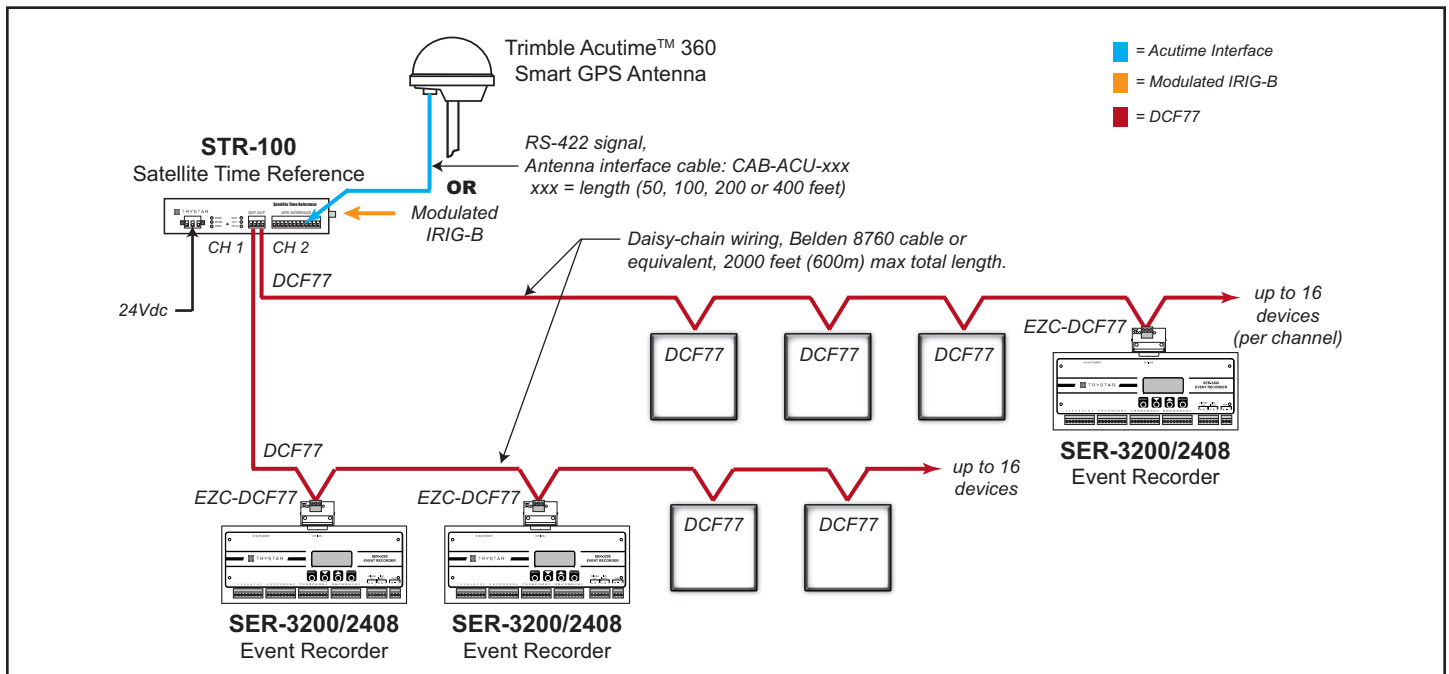

Legacy system architecture # L1: An STR-100 provides a precision time reference for multiple devices via DCF77 cabling.

# SYSTEM L2—DCF77 plus 1per10

STR-100 channel 2 is configurable for DCF77 (default) or 1per10, as shown below.

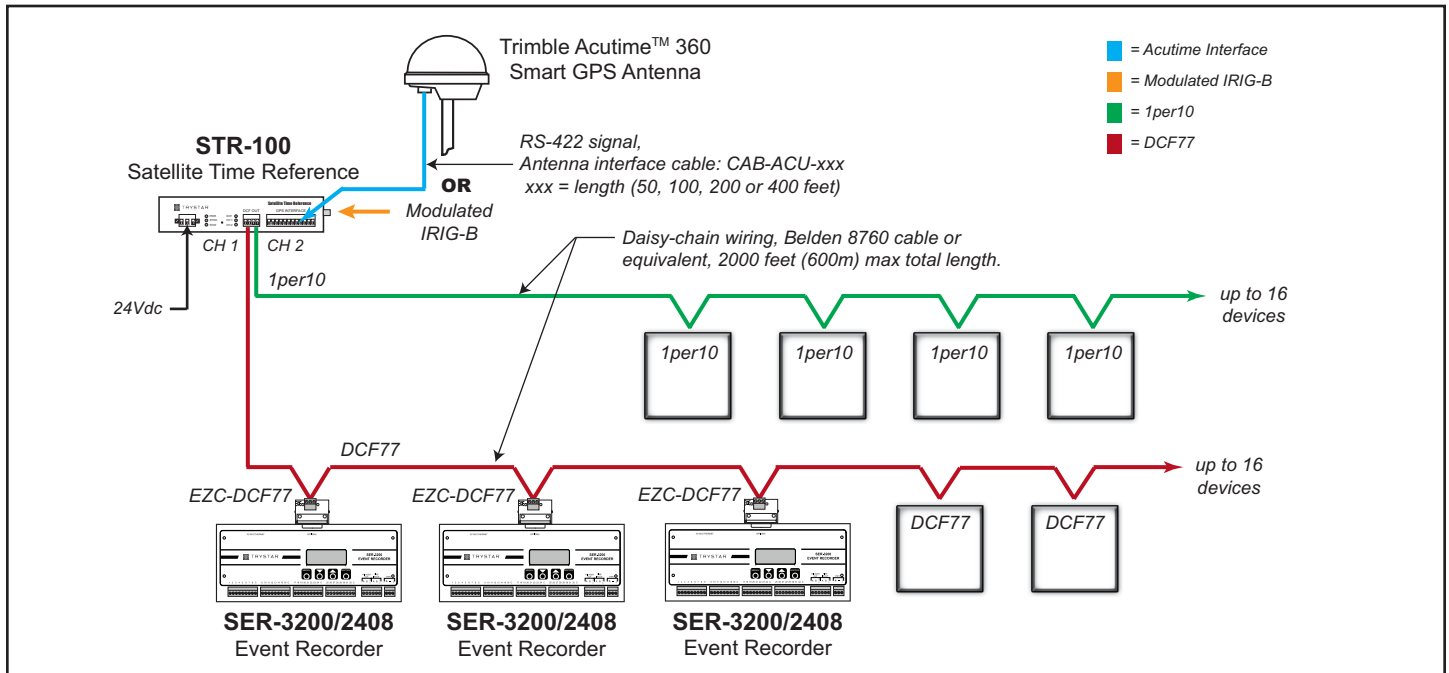

Legacy system architecture # L2: STR-100 provides a precision time reference for multiple devices via DCF77 and 1per10 cabling, as needed.

### SYSTEM L3—All IRIG-B Devices

IRIG-B is typically distributed as a 5 Vdc level shift (DCLS) also known as “Unmodulated IRIG-B.” Shown below is a common GPS receiver/clock which outputs this IRIG-B time code to multiple devices, including a Trystar SER-3200/2408. Refer to the clock manufacturer’s instructions for distance and device limitations for the IRIG-B signal.

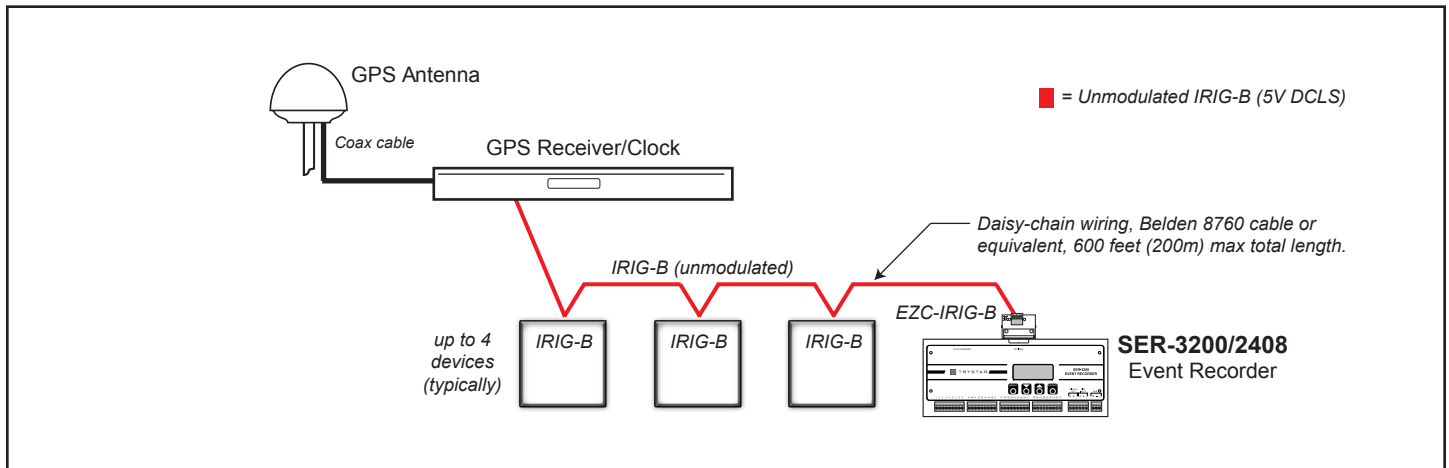

Legacy system architecture # L3: GPS receiver/clock provides a precision time reference for multiple devices via IRIG-B cabling.

### SYSTEM L4—IRIG-B + Inter-SER (RS-485)

In the past, a Trystar SER-3200/2408 could accept IRIG-B or DCF77 as time source and serve as a time-sync master to synchronize additional SER units over its SER inter-device (RS-485) sub-network, as shown below. This was used to extend the IRIG-B time-sync signal to a large number of devices and/or over longer distances.

Today, running redundant RS-485 cables between SER devices is no longer needed; instead, PTP is used to achieve the same performance over Ethernet.

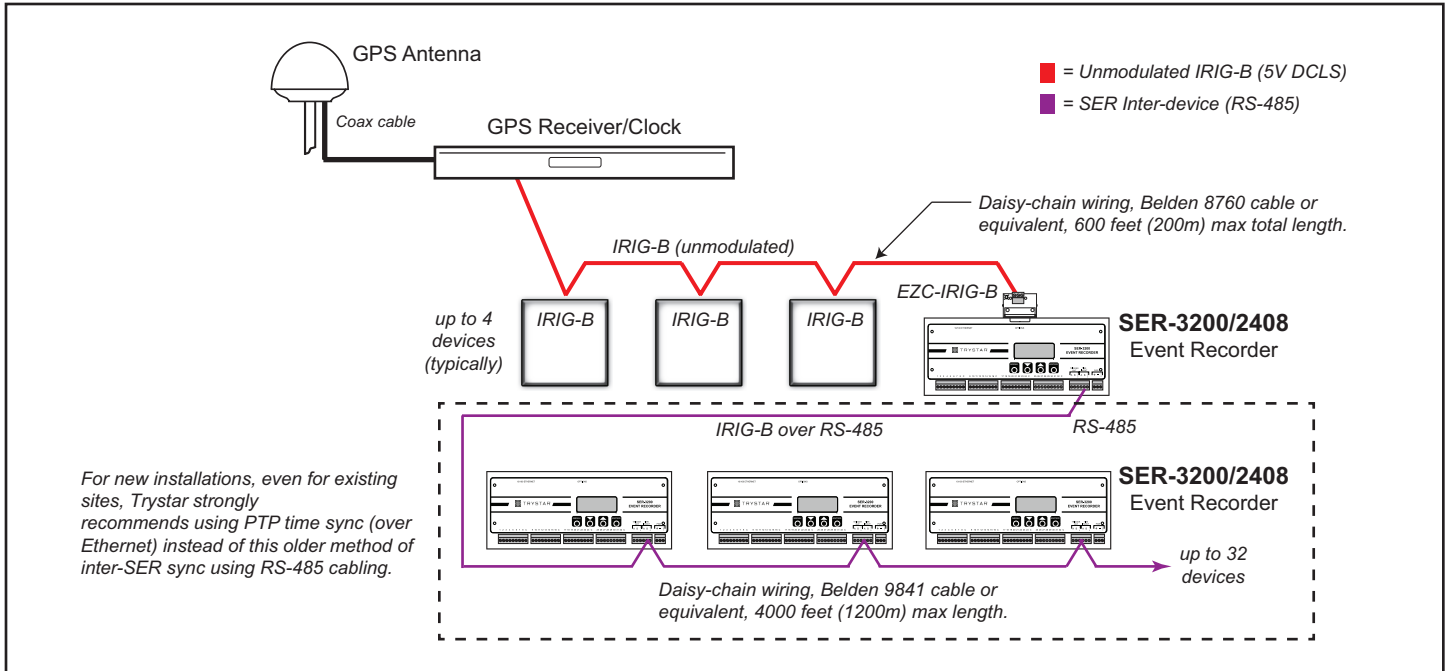

Legacy system architecture # L4: GPS receiver/clock provides a precision time reference to one SER-3200/2408 and others are sync'd via RS-485.

### SYSTEM L5—IRIG-B plus DCF77 Devices

Another legacy system architecture used in the past is the hybrid system shown below to support two types of time protocols: IRIG-B and DCF77. In this example, the GPS receiver/clock outputs a conventional, unmodulated IRIG-B (5V DCLS) signal to devices which can accept this time-sync method. In addition, a modulated IRIG-B signal is connected to the STR-100, which serves as a protocol converter to generate the 24 Vdc DCF77 signal required by the other devices.

Note that the Trystar SER-3200/2408 Event Recorders can accept either IRIG-B or DCF77. In addition, with the advent of PTP, this architecture is no longer practical.

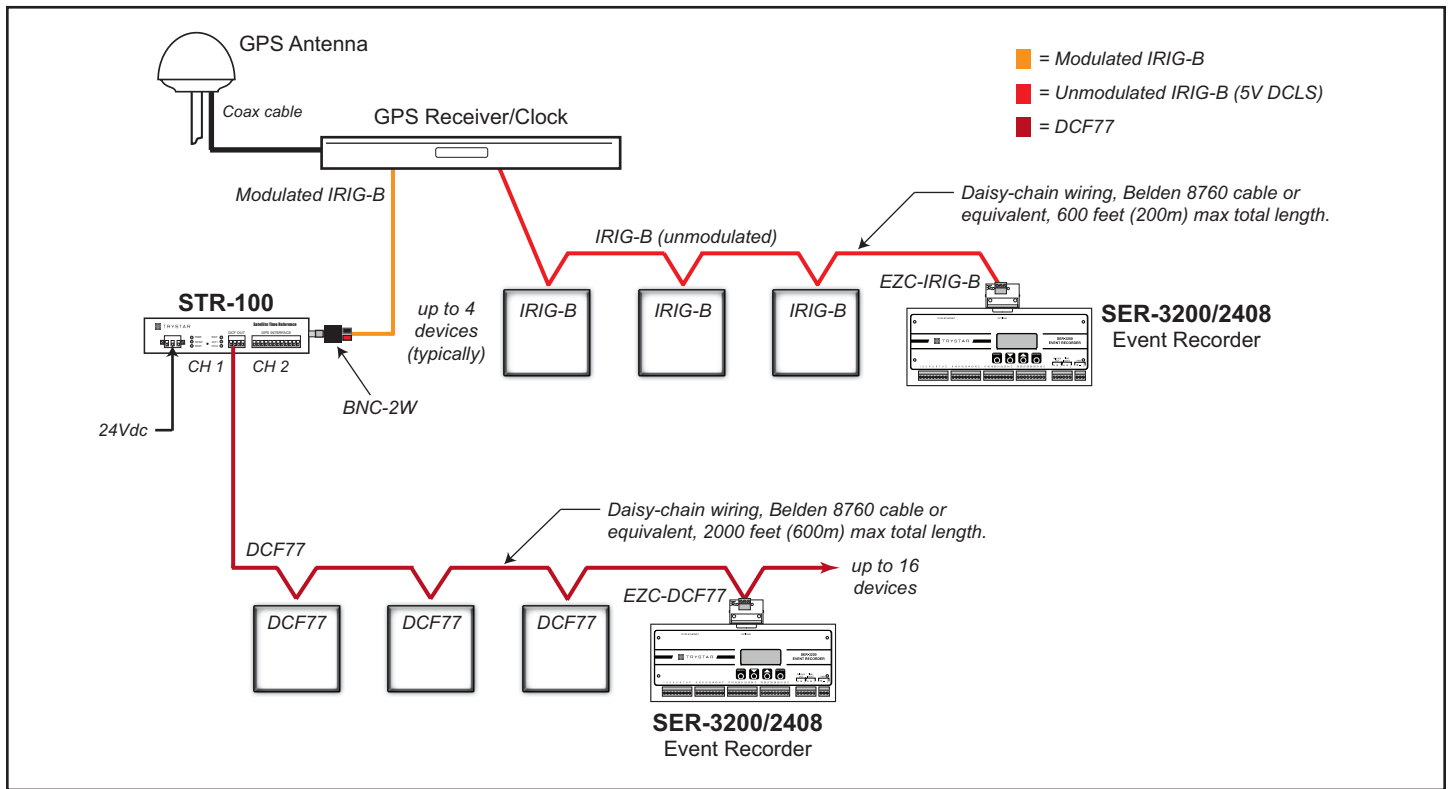

Legacy system architecture # L5: GPS receiver/clock provides a precision time reference for devices via IRIG-B cabling and DCF77 cabling (from STR-100).

## UPGRADING A LEGACY DESIGN TO TAKE ADVANTAGE OF PTP

### Project specs based on a legacy design?

It's quote stage and the specs are based on a legacy (obsolete) design described in the previous section; now what? Or maybe you just won the project, but you quoted it based on a legacy architecture. It may not be too late to take advantage of PTP technology, saving you cost and complexity and delivering a much better solution for the end user.

With legacy protocols, the number and type of devices to be synchronized, the protocols supported, and the distances involved all affect system architecture. Each system must be engineered individually.

### Example: IRIG-B and ASCII/RS-485

In the example below, the system includes devices that support IRIG-B (including Trystar SERs) and meters that require ASCII/RS-485. A GPS clock generates the IRIG-B signal, but since it is distributed at low voltage (5V nominal pulses), multiple circuits are run from the clock. Careful consideration of clock specs, cable distances and device limitations complicate the design.

Repeaters are required, depending on system size (number of devices and/or long distances). In some cases, fiber-optic repeaters may be required for isolation. Each IRIG-B and RS-485 daisy chain must be terminated properly to avoid signal reflections. Additional phases may require additional sets of GPS antenna and clock to scale to support the new system scope.

All models of Trystar SER can accept IRIG-B (or DCF77) as time source and generate the ASCII/RS-485 signal output to the meters that require this, avoiding the need to run additional redundant cables throughout the system.

You may be thinking "there must be a better way." You are right. Please continue reading.

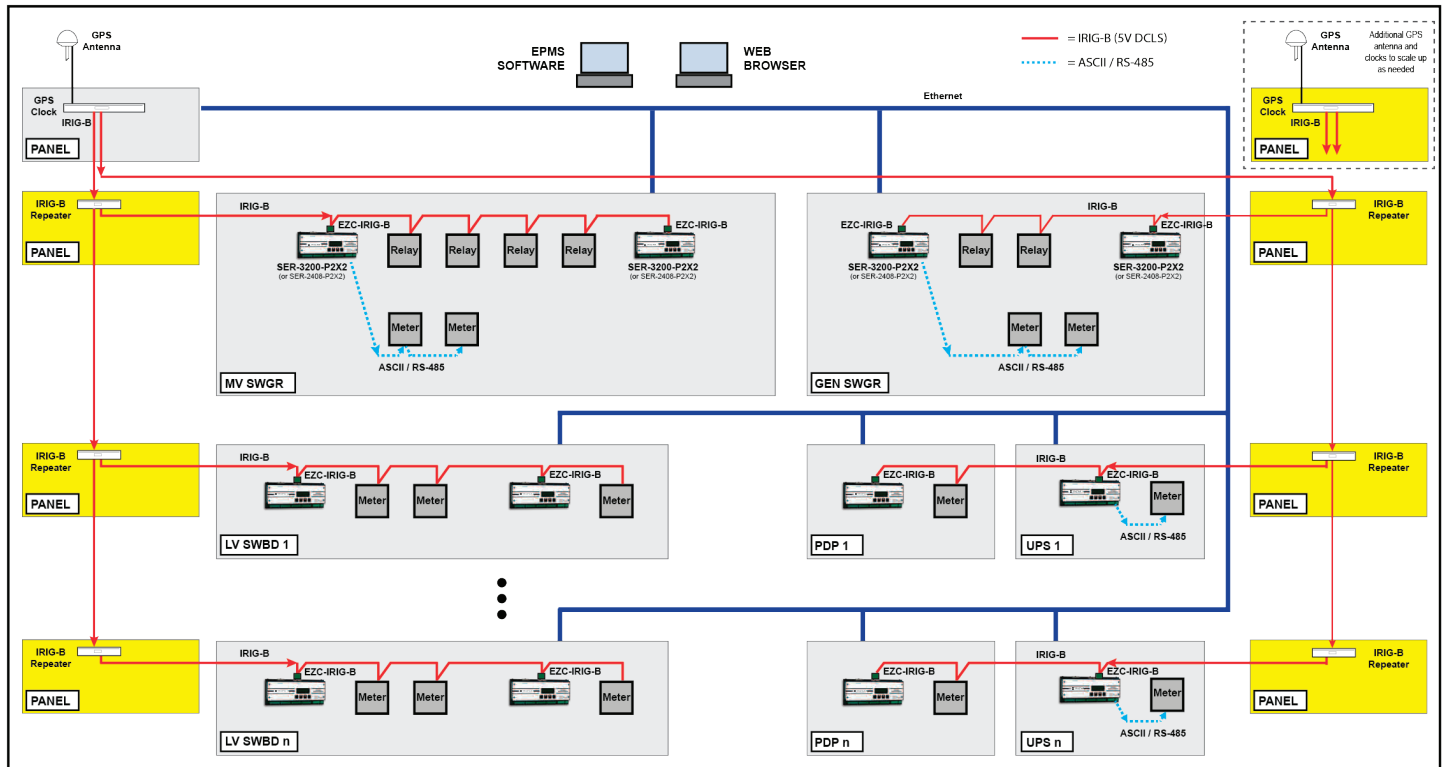

EPMS SYSTEM EXAMPLE—LEGACY DESIGN (IRIG-B AND ASCII/RS-485)

PTP simplifies system design by eliminating redundant cabling between power equipment lineups as well as converters and repeaters required by legacy protocols. By leveraging the existing Ethernet network already used for data communications, distance concerns are eliminated. As shown below, by upgrading the Trystar SERs to PTP models and making other small changes to the previous example with legacy protocols, the time-sync architecture is greatly simplified. In addition, PTP ensures easy scalability as the system grows.

### Example: PTP time sync over Ethernet, with support for IRIG-B and ASCII/RS-485

In the PTP-based design shown below, two SERs accept IRIG-B as their time source from a GPS clock. With this approach, one serves as PTP master, while the other waits in passive mode (standby) for redundancy in case the first is taken out of service. All other Trystar SERs are set to use PTP as their time source (PTP slaves), and sync automatically to the SER serving as PTP master. In addition, these are configured to output the legacy protocol required by nearby devices. Thus, in addition to their main function of event recording, they serve as a PTP “time sync hub” for those devices that do not support PTP directly.

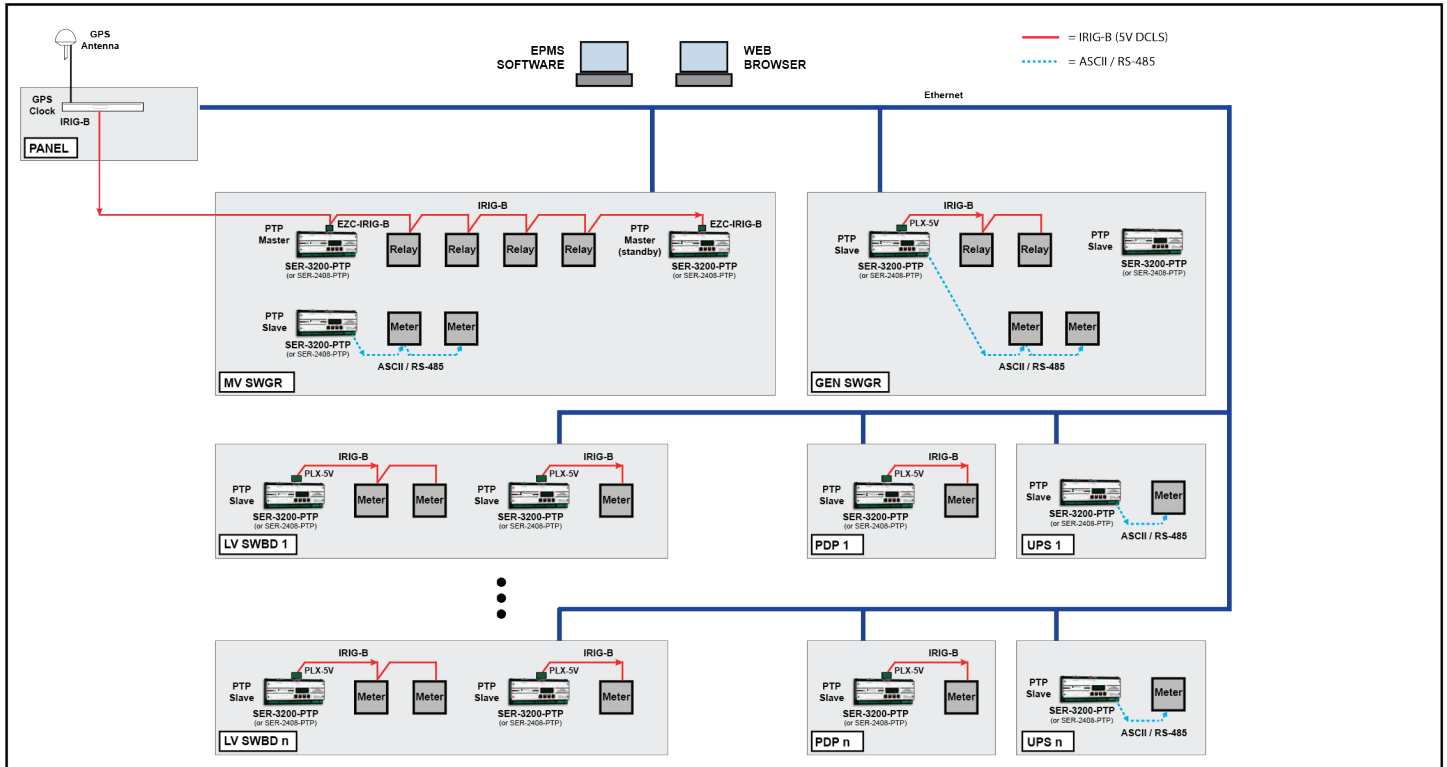

EPMS SYSTEM EXAMPLE—PTP-ENABLED DESIGN (IRIG-B AND ASCII/RS-485)

In the next example, the system includes devices that support IRIG-B as well as some that require DCF77. As in the previous example, a GPS clock generates the IRIG-B signal, distributed by multiple IRIG-B circuits. This time, the need for the second legacy protocol (DCF77) complicates the design further.

### Example: IRIG-B and DCF77

Converters are used, in this case accepting Modulated IRIG-B from the GPS clock and outputting DCF77 at 24 Vdc. As before, each IRIG-B and DCF77 daisy chain should be terminated properly to avoid signal reflections. Also as before, additional phases may require additional sets of GPS antenna and clock to scale to support the new system scope.

All models of Trystar SER can accept either IRIG-B or DCF77 as time source, and so the SERs could be wired for either signal, whichever is more convenient.

In some ways, DCF77 is slightly better suited to power applications than IRIG-B, in that DCF77 is typically distributed as a 24 Vdc signal, not 5 Vdc. The example below shows an extension of the DCF77 daisy-chain across to devices in other equipment enclosures, as might be possible, depending on distances and the total number of devices. However, as before, each system must be carefully engineered individually.

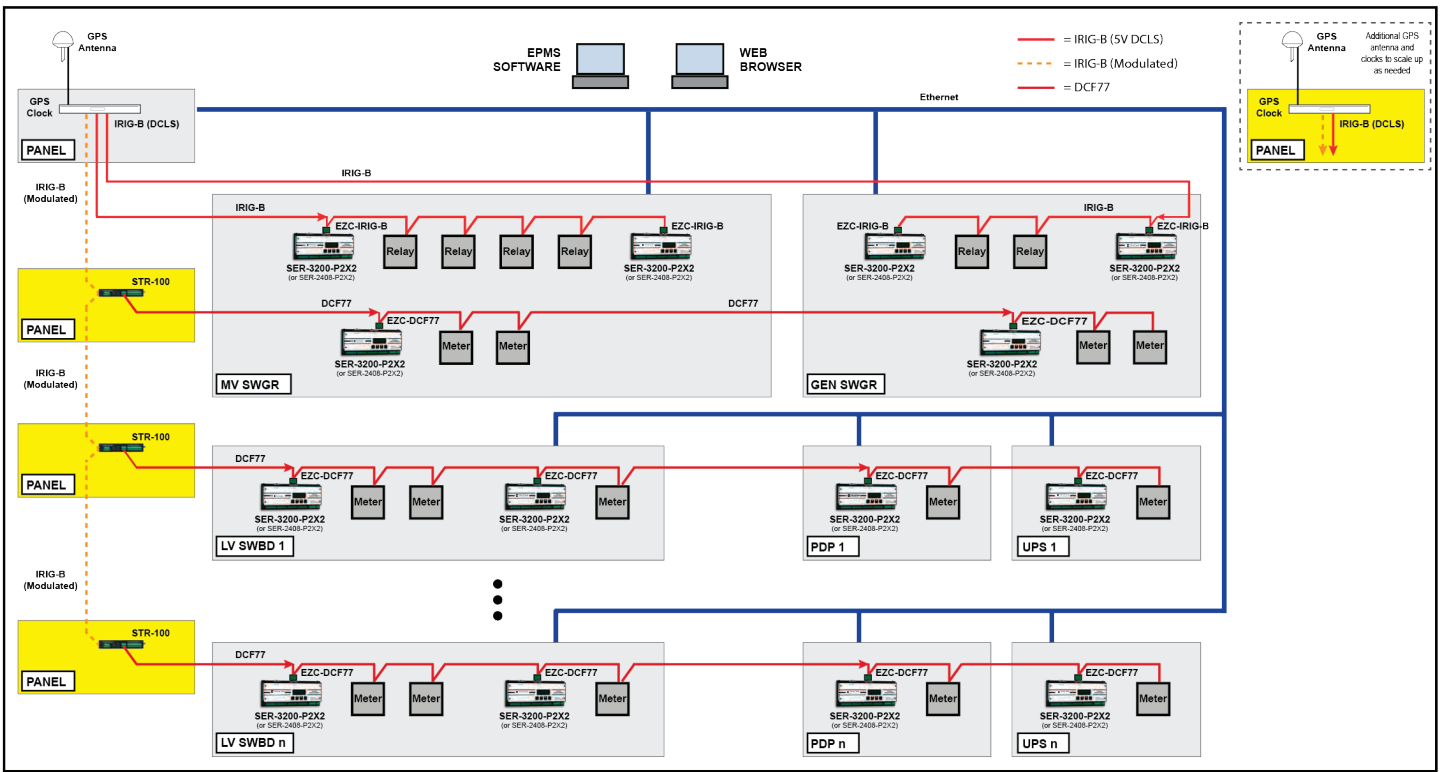

EPMS SYSTEM EXAMPLE—LEGACY DESIGN (IRIG-B AND DCF77)

PTP simplifies system design by eliminating redundant cabling between power equipment lineups as well as converters and repeaters required by legacy protocols. By leveraging the existing Ethernet network already used for data communications, distance concerns are eliminated. As shown below, by upgrading the Trystar SERs to PTP models and making other small changes to the previous example with legacy protocols, the time-sync architecture is greatly simplified. In addition, PTP ensures easy scalability as the system grows.

### Example: PTP time sync over Ethernet, with support for IRIG-B and DCF77

In the PTP-based design shown below, two SERs accept IRIG-B as their time source from a GPS clock. With this approach, one serves as PTP master, while the other waits in passive mode (standby) for redundancy in case the first is taken out of service. All other Trystar SERs are set to use PTP as their time source (PTP slaves), and sync automatically to the SER serving as PTP master. In addition, these are configured to output the legacy protocol required by nearby devices. Thus, in addition to their main function of event recording, they serve as a PTP “time sync hub” for those devices that do not support PTP directly.

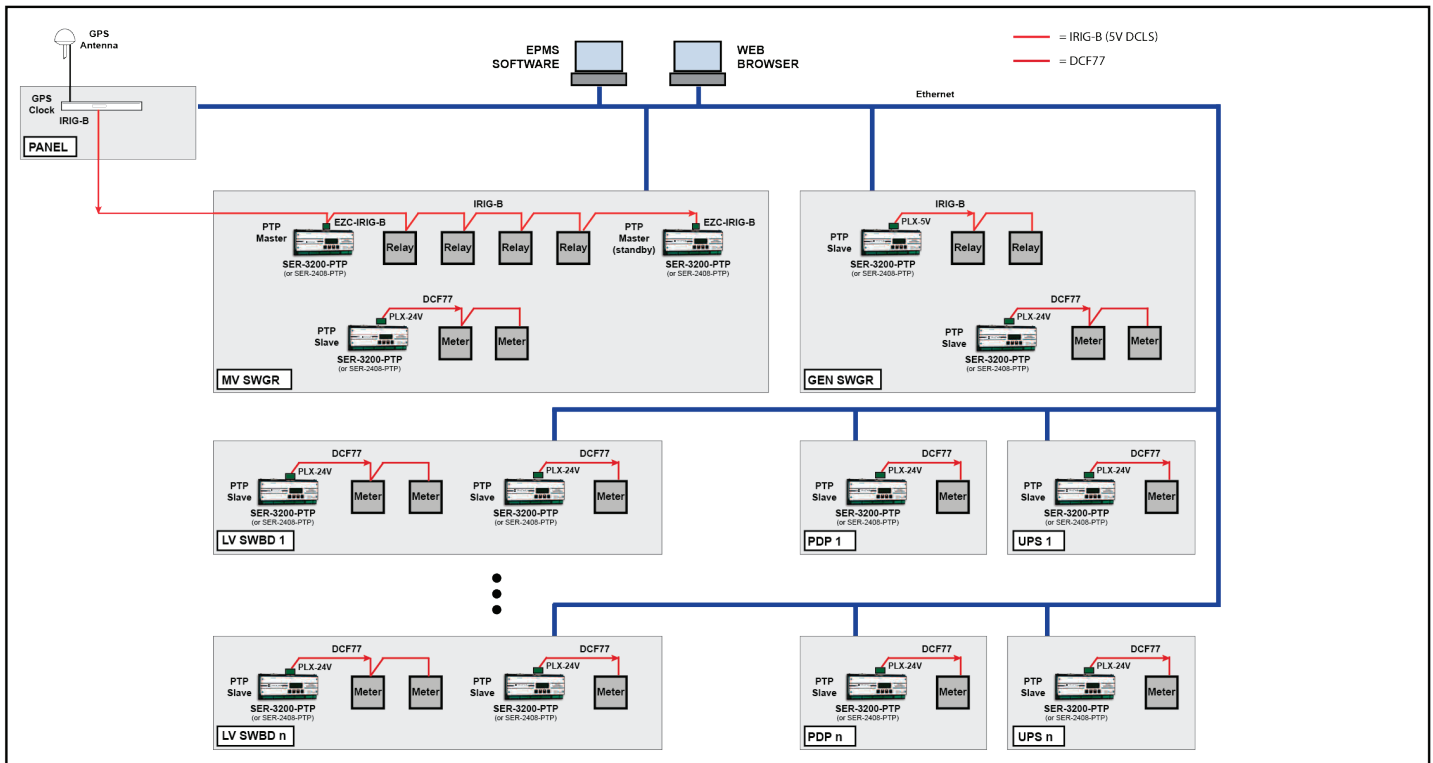

EPMS SYSTEM EXAMPLE—PTP-ENABLED DESIGN (IRIG-B AND DCF77)

## EXTENDING TIME SYNC FROM AN EXISTING SYSTEM

### Extending An Existing IRIG-B Signal

#### Use an Existing IRIG-B Signal to Simplify PTP Time Sync

It is possible to take advantage of PTP technology when adding a section to an existing site with time sync based on legacy protocols. Instead of running long cables from an existing GPS clock or section, just connect the legacy protocol (in this example, IRIG-B) to an SER-3200-PTP (or SER-2408-PTP) through its EZC-IRIG-B connector, then configure the device as a PTP master. As long as all other SERs in the new section are on the same Ethernet LAN, they will sync automatically to the PTP master, within 100 microseconds. In addition, any SER PTP slave can serve as a “PTP time sync hub” as described previously, and sync other EPMS devices using the legacy protocol(s) they require.

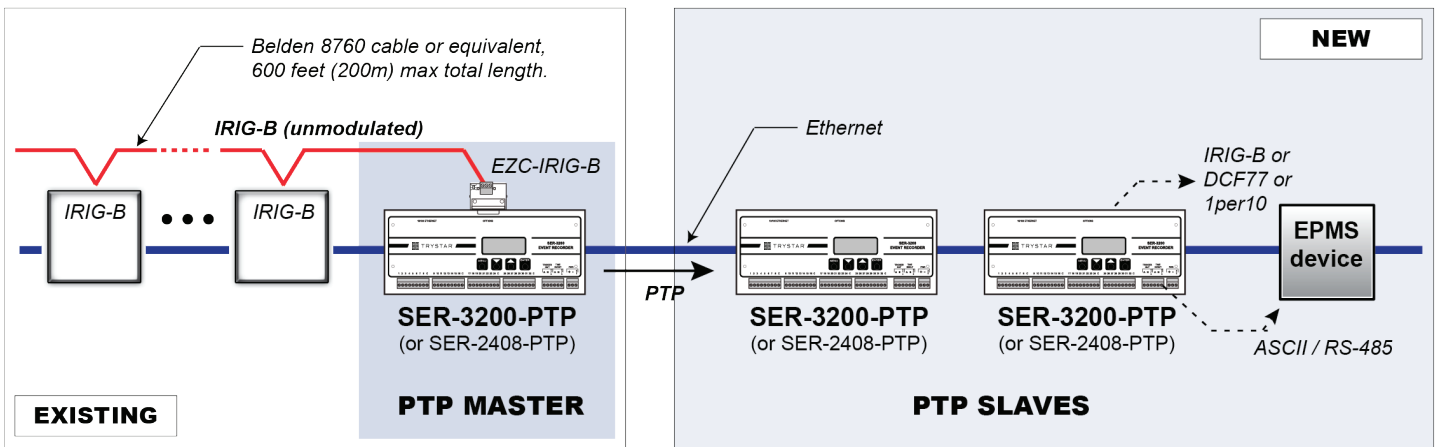
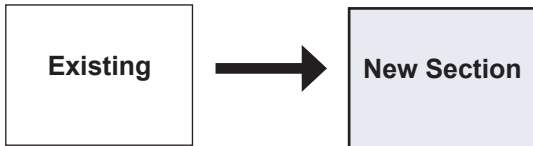

Add new SER-3200-PTP (or SER-2408-PTP) to existing unmodulated IRIG-B daisy-chain (or field upgrade existing SER to PTP model).

### Extending An Existing DCF77 Signal

#### Use an Existing DCF77 Signal to Simplify PTP Time Sync

Similar to the example above, an existing DCF77 signal can be connected to an SER-3200-PTP (or SER-2408-PTP) through its EZC-DCF77 connector, then configured as PTP master. As long as all other SERs in the new section are on the same Ethernet LAN, they will sync automatically within 100 microseconds. In addition, any SER PTP slave can serve as a “PTP time sync hub” as described previously, and sync other EPMS devices using the legacy protocol(s) they require.

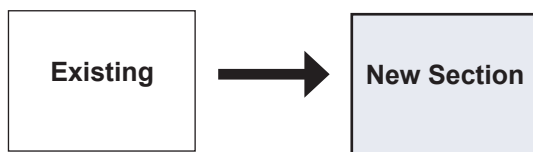

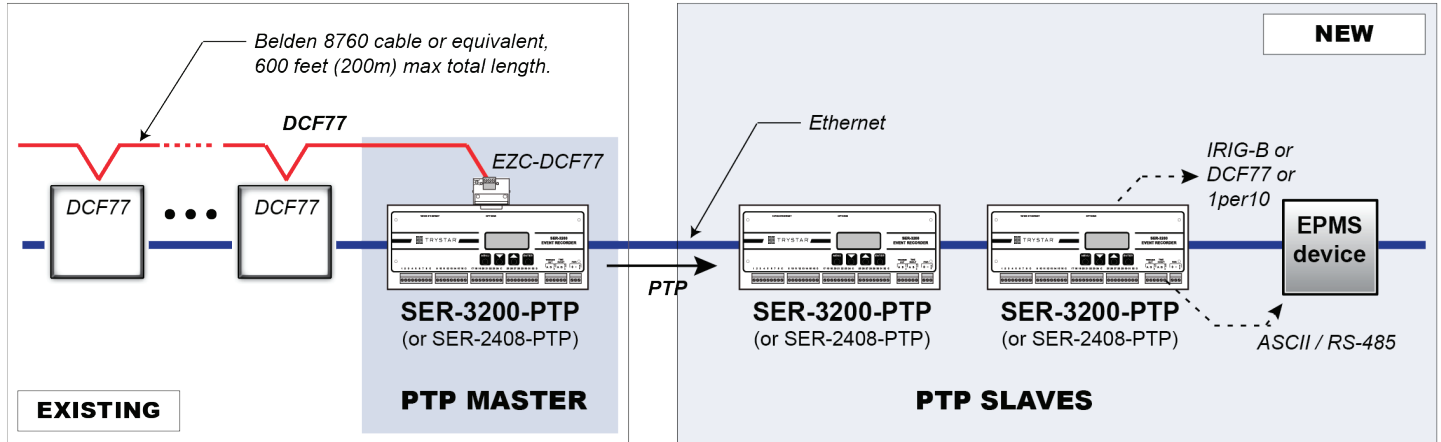

Add new SER-3200-PTP (or SER-2408-PTP) to existing DCF77 (24 Vdc) daisy-chain (or field upgrade existing SER to PTP model).

Existing NTP Server

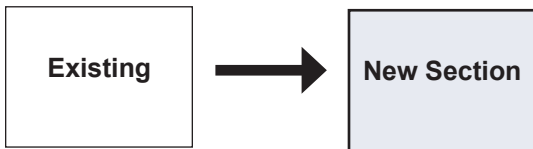

Start with Existing NTP Server, Convert to PTP Time Sync

It is possible to take advantage of PTP technology when adding a section to an existing site with time sync based on NTP as well. Configure an SER-3200-PTP (or SER-2408-PTP) in the new section as a PTP master using NTP as its time source. As long as all other SERs in the new section are on the same Ethernet LAN, they will sync automatically to the PTP master, within 100 microseconds of each other, even if the NTP time is less accurate. In addition, any SER PTP slave can serve as a “PTP time sync hub” as described previously, and sync other EPMS devices using the legacy protocol(s) they require.

Note: this system architecture is presented previously in EPMS system example 2.

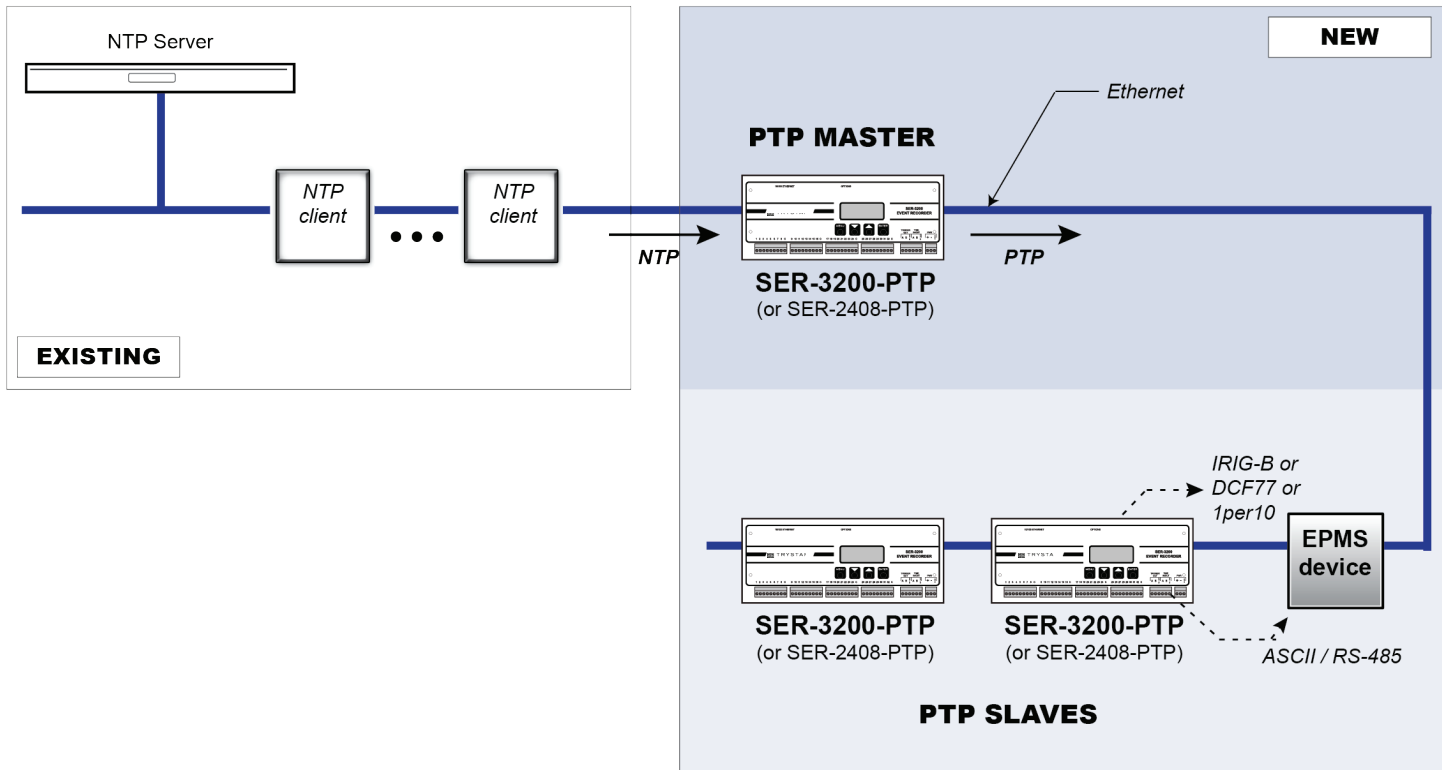

Configure one SER-3200-PTP (or SER-2408-PTP) to use NTP as its time source from the existing NTP server, then enable it as PTP master to sync all other SERs (also PTP models) automatically over Ethernet.

## TECHNICAL REFERENCE

The table below summarizes recommended cable types for various protocols. They are provided only as a guideline. Consult device manufacturers' literature and verify that any cable meets the requirements of your project before ordering materials.

### LEGACY TIME-SYNC PROTOCOLS—CABLE SUMMARY

| Time Protocol  | Max. # of Devices | Max. Distance      | Recommended Cable           | Description   |
|--|-------------------|--------------------|-----------------------------|---|
| IRIG-B, unmodulated (5V DCLS)  | 4                 | 1000 feet (300 m)  | Belden 8760 (or equiv.)     | Shielded, twisted-pair cable, copper, #18 AWG, 300V rms   |
| IRIG-B, modulated  | 4                 | 300 feet (100 m)   | Belden 8760 (or equiv.)     | Shielded, twisted-pair cable, copper, #18 AWG, 300V rms   |
| DCF77  | 16                | 2000 feet (600 m)  | Belden 8760 (or equiv.)     | Shielded, twisted-pair cable, copper, #18 AWG, 300V rms   |
| 1per10 (1 pulse every 10 sec.)   | 16                | 2000 feet (600 m)  | Belden 8760 (or equiv.)     | Shielded, twisted-pair cable, copper, #18 AWG, 300V rms   |
| IRIG-B, unmodulated, @ 24 Vdc plus 24 Vdc power (to/from STR-IDM or PLX) | 8                 | 2000 feet (600 m)  | Belden 8770 (or equiv.)     | Shielded, 3-conductor cable, copper, #18 AWG, 300V rms  |
| IRIG-B, unmodulated, over RS-485 (SER Inter-Device)                      | 32                | 4000 feet (1200 m) | Belden 9841 (or equiv.)     | Shielded, twisted-pair cable, copper, #24 AWG, 300V rms   |
| DCF77, over RS-485 sub-network (SER Inter-Device)                        | 32                | 4000 feet (1200 m) | Belden 9841 (or equiv.)     | Shielded, twisted-pair cable, copper, #24 AWG, 300V rms   |
| ASCII, over RS-485 sub-network (from SER-3200/2408 time-master)          | 16                | 4000 feet (1200 m) | Belden 9841 (or equiv.)     | Shielded, twisted-pair cable, copper, #24 AWG, 300V rms   |
| Trimble Acutime 360 smart GPS antenna interface cable (RS-422)           | 1                 | 400 feet (120 m)   | Acutime 360 Interface Cable | Shielded, six-twisted-pair cable, #22 AWG, with 12-pin connector on one end. Available in lengths of 50, 100, 200 and 400 feet. |
| Antenna interface cable between STR-100s when sharing an antenna         | 7                 | 1000 feet (300 m)  | Belden 8723 (or equiv.)     | Shielded, two-twisted-pair cable, copper, #22 AWG, 300V rms   |

## CABLE TERMINATION

For SER Inter-Device (RS-485) time-sync sub-networks, Trystar recommends using a 120 Ohm resistor (1/4 watt) across the twisted-pair, per the EIA standard. The termination, as the name suggests, should be placed at the end of the network, after the last device on the daisy-chain.

Due to the nature of the signal and baud rates associated with DCF77, 1per10 and IRIG-B time protocols, line termination is normally not required. If cable distances are near their maximum limits and signal reflections are suspected to affect reliable operation, line terminations may be added as follows:

If desired, Trystar recommends using a 100 Ohm resistor (1/4 watt)

across the signal pair, in series with a 0.01  $\mu\text{F}$  (microfarad) capacitor. This will minimize reflections of the time-code pulse. The signal pair, in series with a 0.01  $\mu\text{F}$  (microfarad) capacitor. This will minimize reflections of the time-code pulse.

## PRACTICAL CONSIDERATIONS

The suggested distance limits and max devices suggested in this document are based on standard specifications, factory testing and field experience. Some of the recommendations may be conservative, and few are absolute limits. While it may be technically feasible to exceed such guidelines, the total distance and number of devices on a given segment should be kept as small as possible for practical reasons. For example, rather than combine 30 or more devices on the same chain, it may be better to split these into two segments if possible, simply to avoid costly troubleshooting later.

## SUMMARY

### Power Management in High Definition

Modern power monitoring systems require 1-msec time-stamping, and so “hi-def” time sync (accuracy  $<100 \mu\text{s}$ ) is required. SER devices record the exact time of power system events (1-msec timestamping), enabling root-cause analysis, identifying slow breakers and allowing operators to verify proper system operation. Until recently, separate, redundant cabling (often involving multiple protocols) was needed, limiting the benefits to only the largest projects.

Precision Time Protocol (PTP), defined in IEEE 1588, enables hi-def time sync over Ethernet. Simple PTP (SPTP) makes PTP relevant for commercial/industrial power systems, extending the benefits of precision timing to a broader market, even those previously forced to compromise performance or functionality to keep costs low. The PTP-enabled solution is simple, affordable and completely scalable, from a few devices to the largest installation.

This document presented examples of the most cost-effective system architectures and showed typical applications of Trystar products. Since some relays and meters do not yet support PTP, Trystar provides ways for these to be “PTPenabled” too.

### References

1. IEEE Std 1588™-2008, IEEE Standard for a Precision Clock Synchronization Protocol for Networked Measurement and Control Systems.
2. IEEE Std C37.238-2011, IEEE Standard Profile for Use of IEEE 1588™ Precision Time Protocol in Power System Applications
3. Kennedy, Robert A., P.E., “GPS Time Synchronization: How precision timing and sequence of events recording will make the Smart Grid even smarter,” *Electrical Construction & Maintenance (EC&M)* magazine, August 19, 2011, pp. 18-20.

**For More Information**

EPMS-HD Data Sheet  
 Tech Note: Hi-res Time Sync using  
 Tech Note: IRIG-B Time Codes  
 Tech Note: DCF77 Time Protocol  
 Tech Note: 1per10 Time Protocol  
 Tech Note: ASCII/RS-485  
 Trystar SER User's Guide  
 Trystar SER Reference Guide  
 EZC Instruction Bulletin  
 PLX Instruction Bulletin  
 STR-100 Instruction Bulletin  
 STR-IDM Instruction Bulletin  
 SER System Guide Specs

<http://ecmweb.com/computers-amp-software/gps-time-synchronization>

4. Brown, PE, Bill, and Mark Kozlowski, "Power System Event Reconstruction Technologies for Modern Data Centers," Square D Critical Power Competency Center. Aug. 2006.
5. Dickerson, Bill, P.Eng., Arbiter Systems, Inc. "Time in the Power Industry: How and Why We Use It."
6. Product instruction bulletins for relays and meters from ABB, Eaton, GE, Schneider Electric, Siemens and others referenced in this document.



