

Satellite Time
Reference
STR-100

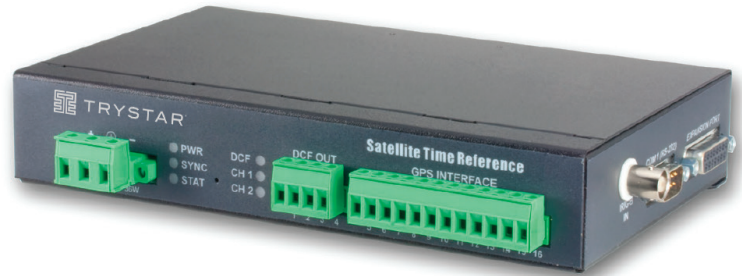

TABLE OF CONTENTS



Note: STR-100/IRIG-B Addendum
 Most of this bulletin applies equally to both models, STR-100 and STR-100/IRIG-B. For additional details on the STR-100/IRIG-B, refer to Addendum IB-STR-02.

- INTRODUCTION -----2
- PRODUCT OVERVIEW-----2
- THEORY OF OPERATION -----3
- CATALOG NUMBERS -----3
- INSTALLATION-----4
- MOUNTING CONSIDERATIONS-----4
- DIMENSIONS-----4
- DIN-RAIL MOUNTING-----5
- SURFACE PLACEMENT -----5
- WALL / PANEL MOUNTING-----6
- WIRING -----7
- WIRING CONNECTIONS -----7
- WIRING CONTROL POWER -----8
- TIME PROTOCOL OUTPUT -----8
- GPS ANTENNA INTERFACE-----9
- EXPANSION PORT ----- 10
- RESET BUTTON ----- 10
- SETUP ----- 11
- CONFIGURING THE STR----- 11
- SET YEAR (IRIG SOURCE ONLY)----- 12
- SET LOCAL TIME OFFSET ----- 12
- SET DAYLIGHT SAVING TIME----- 13
- SET PARAMETERS TO FACTORY VALUES----- 14
- VIEW PARAMETERS ----- 15
- WATCH DCF OUTPUT ----- 15
- WATCH GPS INPUT ----- 16
- ACUTIME ----- 16

ERROR COUNTS -----	18
SET OUTPUT PROTOCOL -----	19
SUMMARY OF ALL DEFAULT VALUES -----	19
OPERATION -----	20
NORMAL OPERATION -----	20
INDICATOR LEDS -----	20
SPECIFICATIONS -----	21
FREQUENTLY ASKED QUESTIONS (FAQS) -----	22
NOTES -----	24

SAFETY PRECAUTIONS

Important safety precautions must be followed before attempting to install, service, or maintain electrical equipment. Carefully read and follow the safety precautions outlined below.



HAZARD OF ELECTRIC SHOCK, EXPLOSION, OR ARC FLASH

- Only qualified workers should install this equipment. Such work should be performed only after reading this entire set of instructions.
- NEVER work alone.
- Before performing visual inspections, tests, or maintenance on this equipment, disconnect all sources of electric power. Assume that all circuits are live until they have been completely de-energized, tested, and tagged. Pay particular attention to the design of the power system. Consider all sources of power, including the possibility of backfeeding.
- Apply appropriate personal protective equipment (PPE) and follow safe electrical practices. For example, in the USA, see NFPA 70E.
- Turn off all power supplying the equipment in which the device is to be installed before installing and wiring the device.
- Always use a properly rated voltage sensing device to confirm that power is off.
- Beware of potential hazards, wear personal protective equipment, and carefully inspect the work area for tools and objects that may have been left inside the equipment.
- The successful operation of this equipment depends upon proper handling, installation, and operation. Neglecting fundamental installation requirements may lead to personal injury as well as damage to electrical equipment or other property.

Failure to follow these instructions can result in death or serious injury.

NOTE:

Electrical equipment should be serviced by qualified personnel. No responsibility is assumed by Cyber Sciences for any consequences arising out of the use of this material. This document is not intended as an instruction manual for untrained persons.

INTRODUCTION

Product Overview

The STR-100 Satellite Time Reference uses Global Positioning System (GPS) technology to provide a highly-accurate date/time reference for Sequence of Events Recording (SER) and other critical power applications. The STR-100 accepts an input from a Trimble Acutime 360 “smart antenna” or an amplitude-modulated (AM) IRIG-B source and outputs a time reference signal accurate to +/- 50 microseconds using standard time protocols: DCF77 and 1per10 (base model) or unmodulated IRIG-B (model STR-100/IRIG-B). Up to 32 devices can be synchronized from one STR-100.

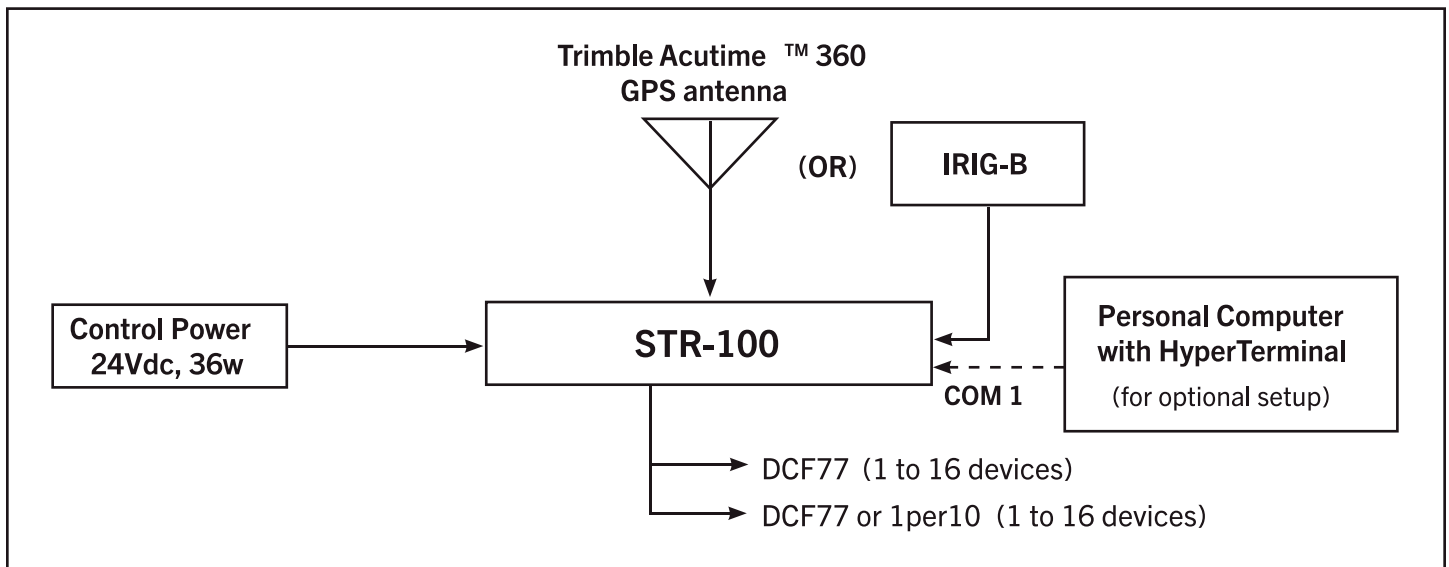

Figure 1-1. STR-100 system diagram

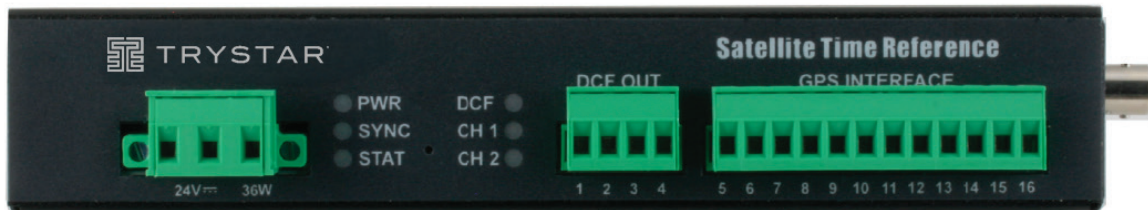

Figure 1-2. STR-100 front view (with connectors removed)



Figure 1-3. STR-100 right side view

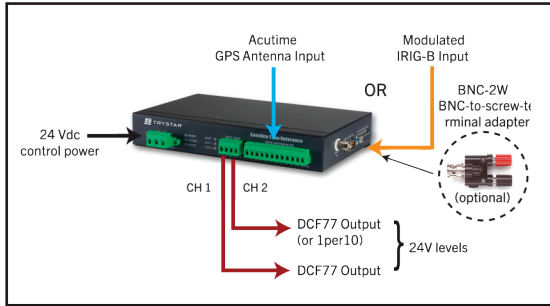

Figure 1-4. STR-100 Inputs/Outputs

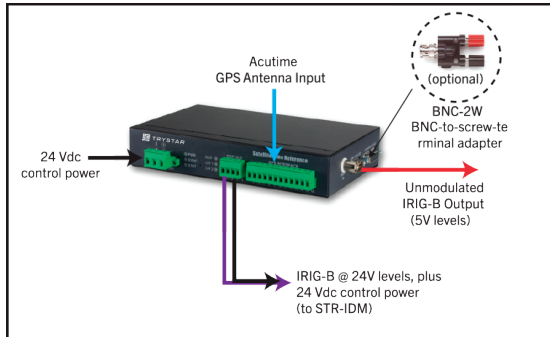

Figure 1-5. STR-100/IRIG-B Inputs/Outputs

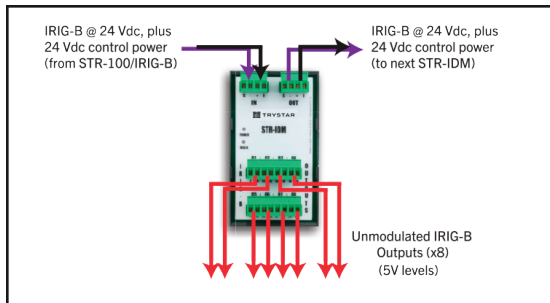

Figure 1-6. STR-IDM Inputs/Outputs

Theory of Operation

The STR-100 accepts a GPS time signal input from either a Trimble Acutime 360 GPS smart antenna or from a GPS receiver with IRIG-B output, and provides a time synchronization output in DCF77 or 1per10 format for multiple devices. Typical power distribution applications include Sequence of Events Recording (SER) systems in data centers, hospitals and refineries, and electric utility “Smart Grid” applications such as Power SCADA and substation automation.

DCF77 is a time synchronization protocol used widely. The DCF77 time synchronization output is a 24Vdc pulse-width modulated signal that provides a complete date/time string once a minute. The signal contains a one-pulse-per-second component that is accurate to +/- 50 microseconds in reference to UTC (Coordinated Universal Time). The pulse string contains a BCD (Binary Coded Decimal) value for minute, hour, day, day of week, month, and year, as well as other control parameters such as leap second and Daylight Saving Time.

1per10 is a simpler time protocol that uses one synchronizing pulse every 10 seconds. Only channel 2 of the STR-100 time output can be configured for 1per10. The default output for both channels is DCF77.

On power-up, the STR determines the type of GPS data source, first checking for an Acutime antenna signal. If an antenna signal is not detected, the STR checks for an IRIG-B signal. During the detection test, the STAT (status) LED flashes twice repeatedly. Once a signal is detected, the SYNC LED is turned on, and normal operation begins. During normal operations, the SYNC LED remains lit, and the STAT LED flashes repeatedly according to the type of receiver: three blinks for IRIG-B, and four blinks for Acutime. The STR captures the date and time each second, and outputs the DCF77 date and time at the top of each minute.

Optional adjustments may be made for local time offset and Daylight Saving Time (DST). The purpose of the local time offset is to convert UTC time into local time, and its value depends on the user’s time zone. If the user sets parameters for Daylight Saving Time, then the STR makes this adjustment as well.

Catalog Numbers

Table 1-1 – Catalog Numbers

Catalog no.	Description
STR-100	Satellite Time Reference, DCF77 and 1per10 output
STR-100/IRIG-B	Satellite Time Reference, unmodulated IRIG-B output
STR-IDM	IRIG-B Distribution Module for STR

NOTE:

For information about the STR-100/IRIG-B or STR-IDM, refer also to instruction bulletins IB-STR-02 and IB-IDM-01, respectively.

INSTALLATION

Mounting Considerations

The STR-100 can be set on a flat surface, mounted to a wall or panel using screws, or DIN-rail mounted to a wall or panel using the DIN-rail mounting kit provided. Figure 2-1 shows STR dimensions. Figures 2-2, 2-3 and 2-4 detail the various mounting options.

When choosing a mounting location, consider the following points:

- Allow for easy access to the STR-100.
- Allow space for all wires to be neatly routed down the side or bottom of the device.
- Allow sufficient ventilation to avoid exceeding the operating temperature limits of the device.

Typical locations for mounting the STR-100 include the following:

- Power equipment instrumentation compartment
- Office or raised-floor environment
- Auxiliary control panel or cabinet

Dimensions

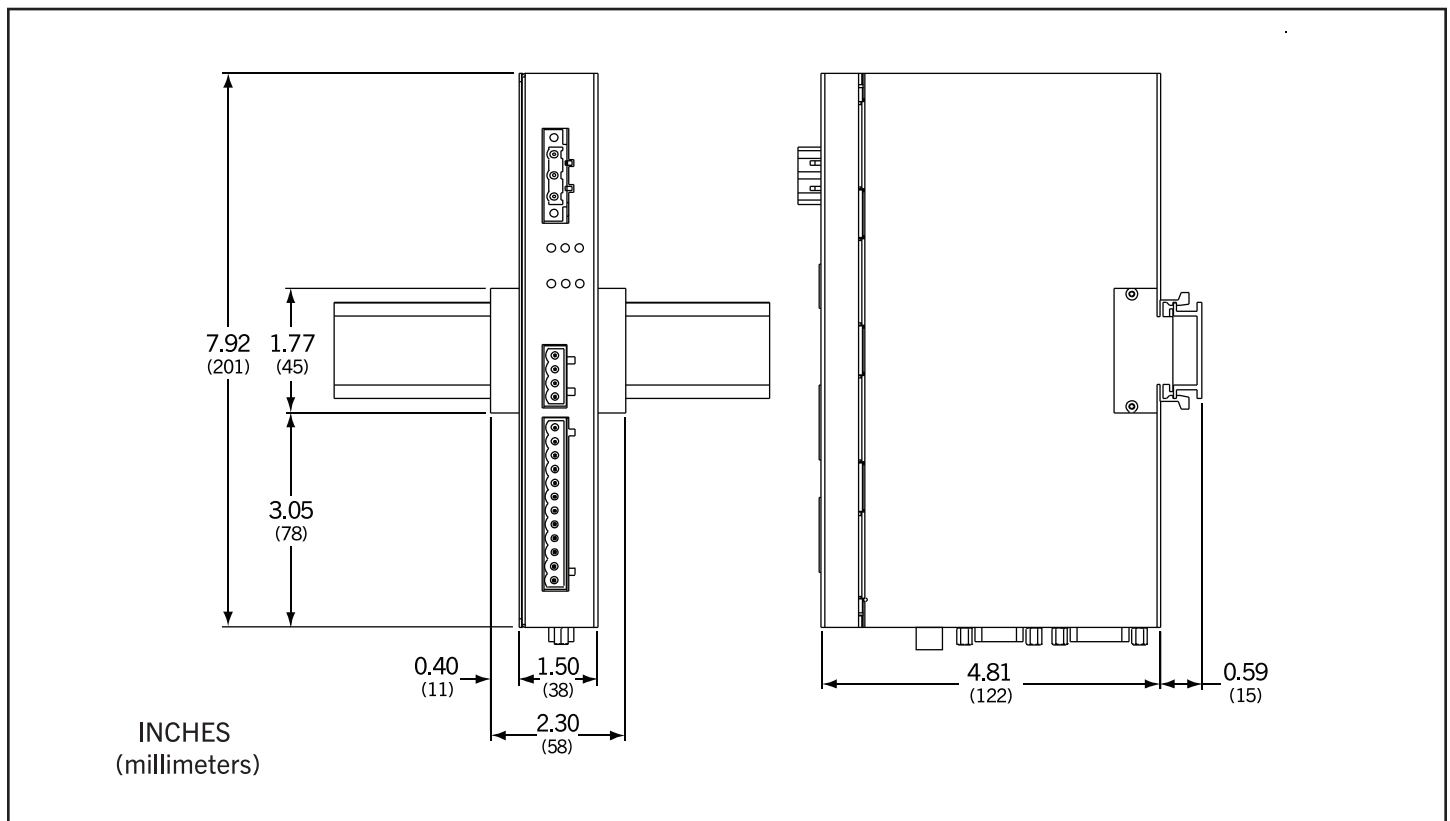

Figure 2-1. STR-100 front and side views of DIN-rail mounting, with dimensions

DIN-Rail Mounting

The STR-100 is suitable for DIN-rail mounting as shown below. The DIN-rail mounting kit (plastic support brackets) are provided.

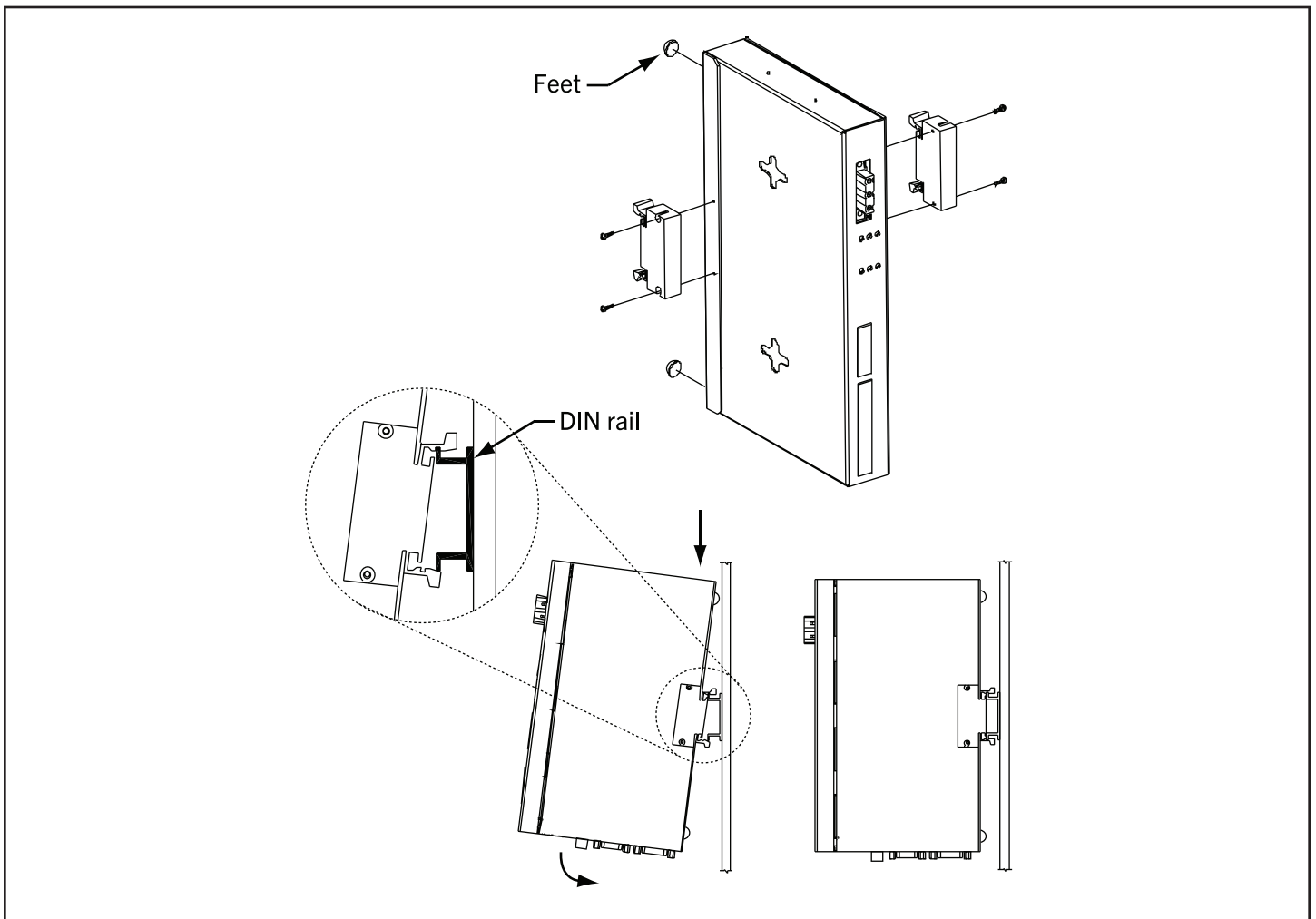

Figure 2-2. STR-100 mounting on standard DIN rail

Surface Placement

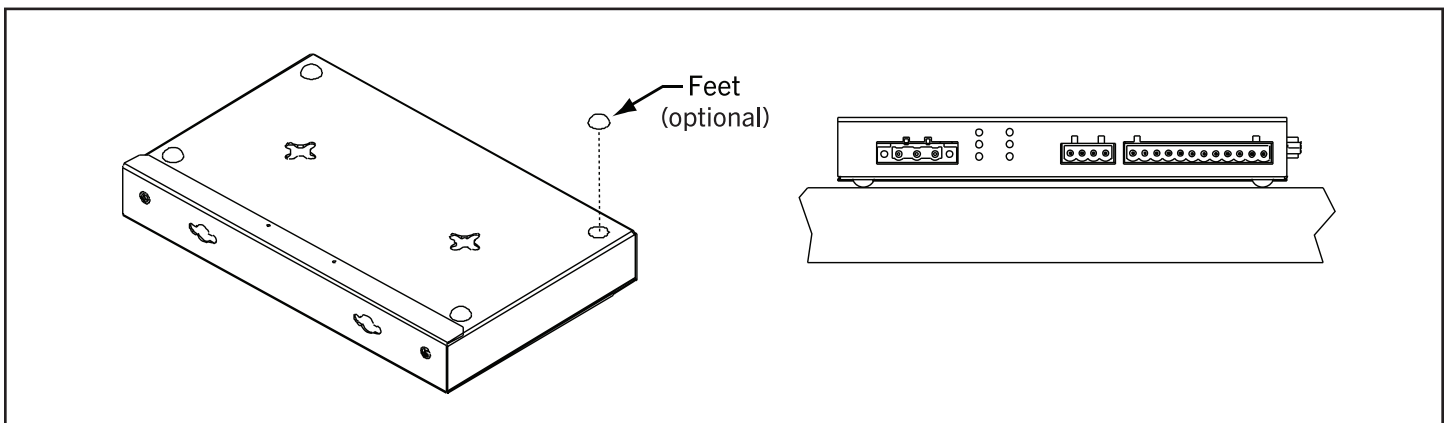

Figure 2-3. Installing feet for flat surface placement of STR-100

Wall / Panel Mounting

The STR-100 has slotted screw holes on the bottom and rear that may be used to mount the device to a wall or fl at panel.

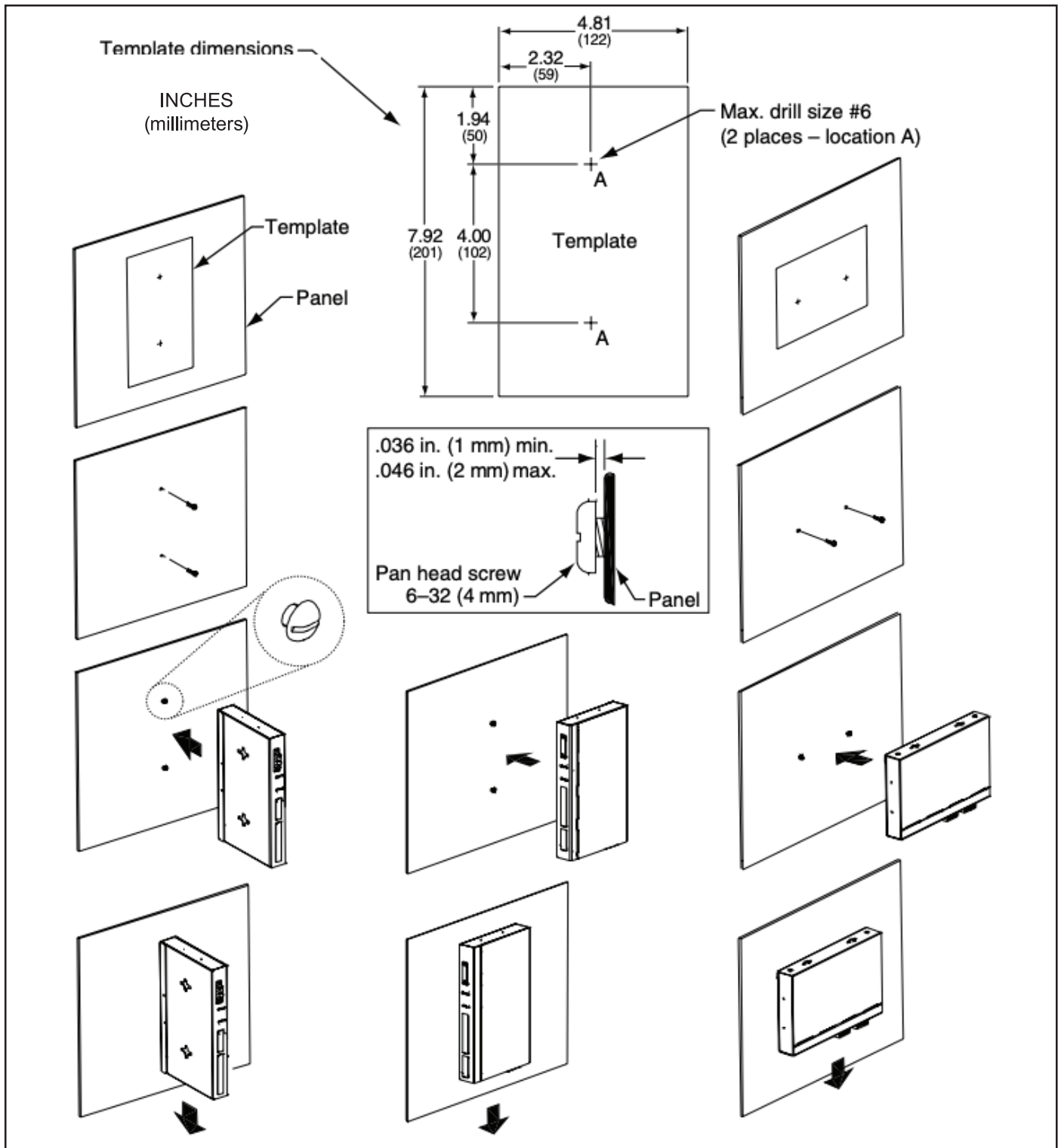

Figure 1-2. STR-100 front view (with connectors removed)

WIRING

Wiring Connections

The physical wiring connections of the STR-100 are shown below:

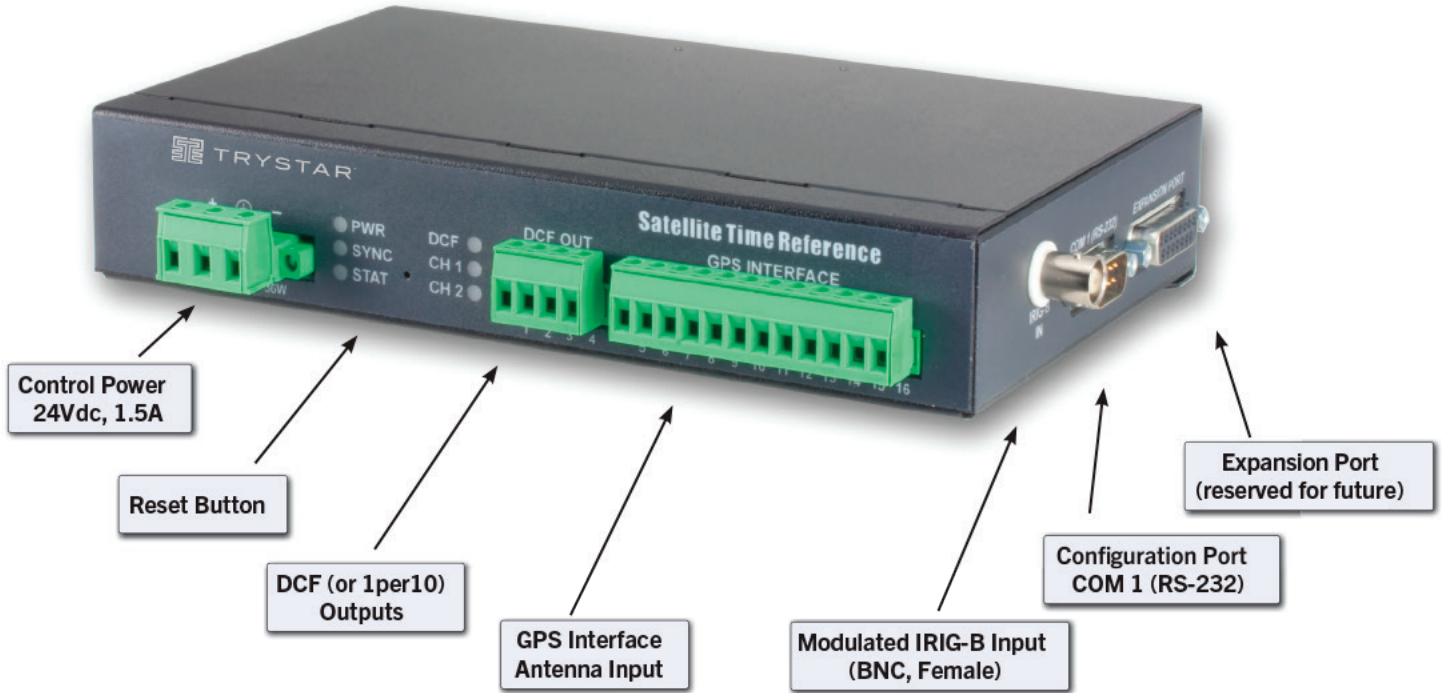

Figure 3-1. STR-100 physical wiring connections (shown with front connectors removed)

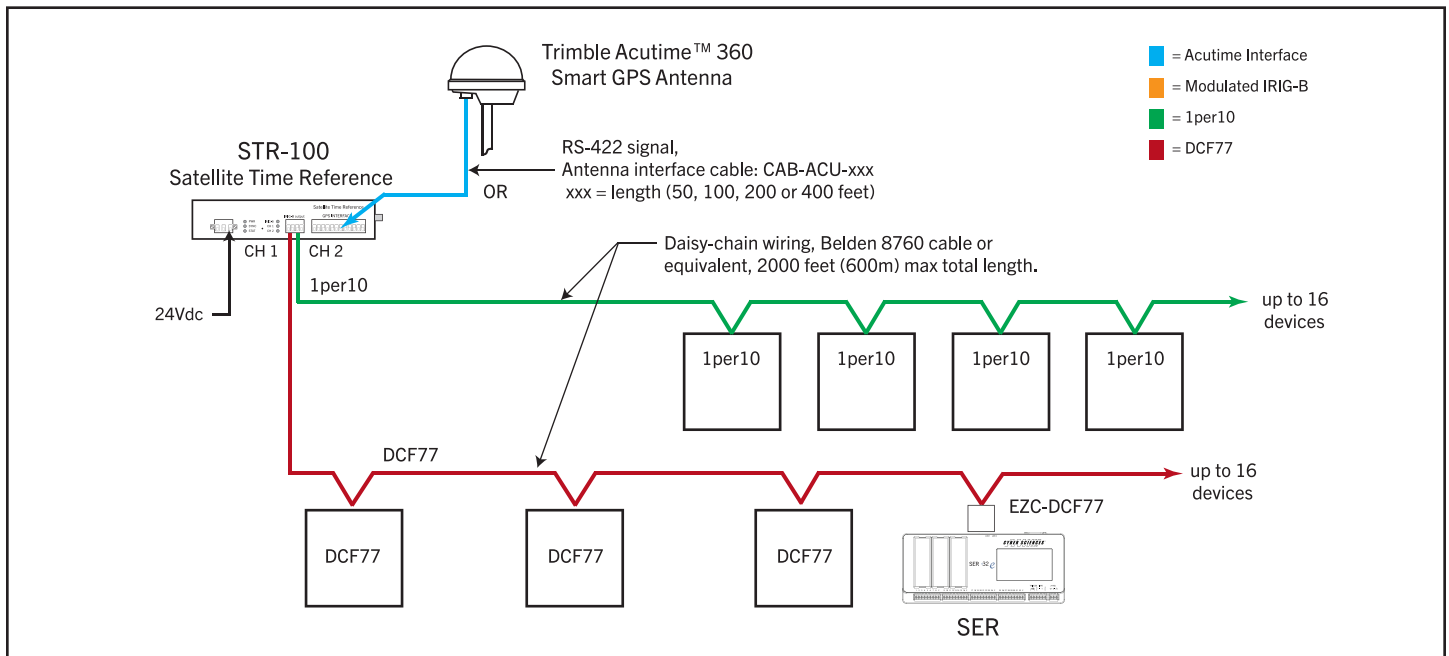

Fig. 3-2. Typical GPS system architecture showing STR-100 with DCF77 and 1per10 time sync output signals

Note: The common connection from the 24Vdc power supply should not be connected to green-wire ground unless specified by local electrical codes.

Wiring Control Power

The STR-100 requires a control power source of 24Vdc, nominal, with the ability to provide up to 36 watts (depending on the number of devices). The power supply should be Class 2 rated with a minimum of 1500 volts of isolation. Use 18 AWG wire (minimum), and limit the control power cable length to 10 meters (32.8 feet) or less.

The STR control power connector has three terminals. The two outside terminals are for the 24Vdc positive and common connections to the power supply. The middle terminal is a safety ground connection (green-wire ground). The figure below provides details for the control power wiring.

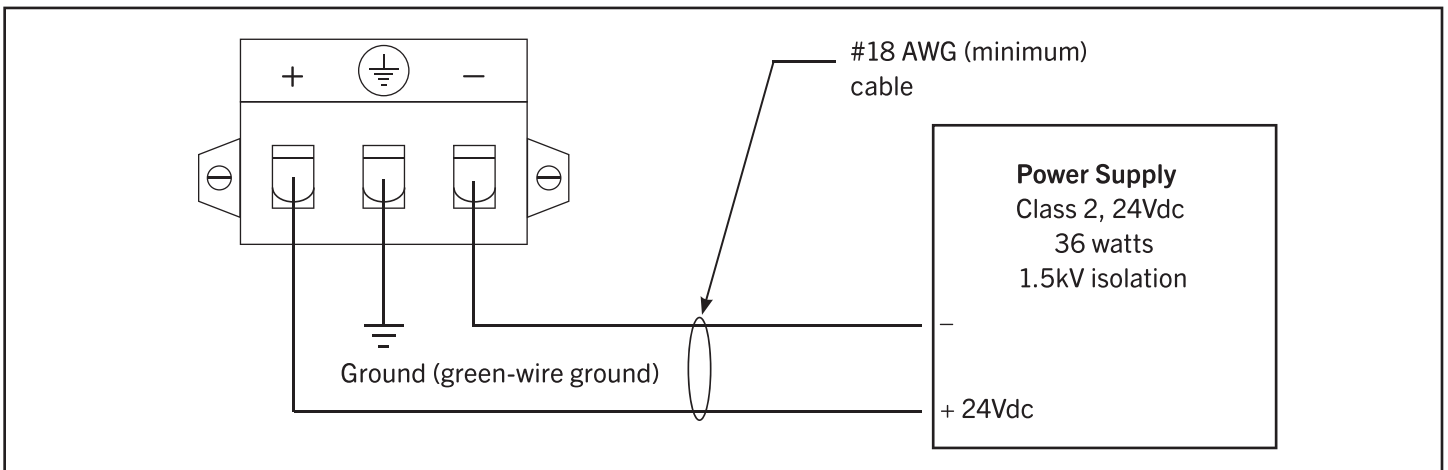

Figure 3-3. Control power connections

Time Protocol Output

The STR-100 provides two time protocol outputs. Channel one is set to output DCF77 and channel two is user-configurable for either DCF77 (default) or one-pulse-per-ten (or “1per10”). Each output channel provides a 24Vdc pulse-width modulated signal with the ability to source 500mA. The figure below illustrates these connections.

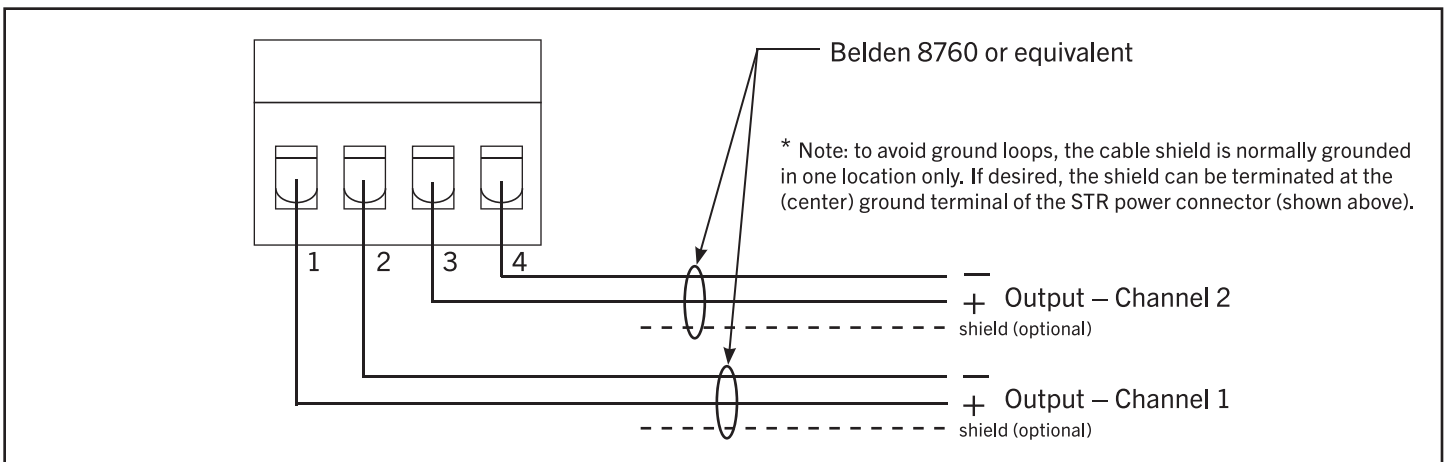

Figure 3-4. Time protocol output connections

GPS Antenna Interface

The primary GPS time reference signal for the STR-100 is a Trimble Acutime 360 GPS smart antenna. The figure below provides details for connecting the antenna to the STR-100 using a Trimble Acutime antenna interface cable. This cable is terminated with a weather-proof DIN connector at the antenna end and is un-terminated (flying leads) at the STR-100 end.

Note: Two or more STRs can share an input from a single Acutime 360 GPS antenna. For more details, see Tech Note: Multiple STRs Can Share a Single GPS Antenna (TN-105)

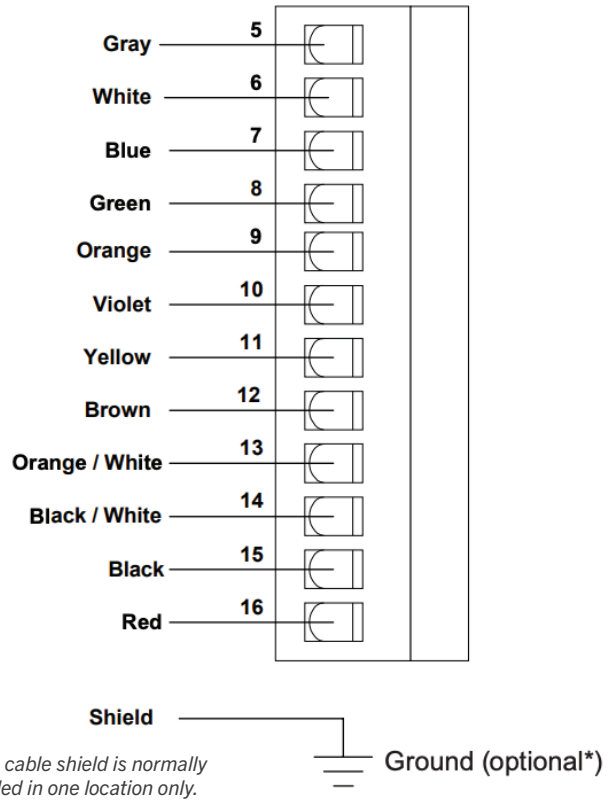

Figure 3-5. Acutime GPS antenna interface connections

IRIG-B Input

Supplying a modulated IRIG-B time reference to the STR-100 is accomplished by connecting a coaxial cable from an IRIG-B source (e.g., GPS receiver) to the IRIG-B input on the STR-100. The IRIG-B input on the STR-100 is a female BNC connector. Refer to the manual for the IRIG-B generator supplying the time reference signal to the STR-100 for recommended cable type and length limitations.

Note: If the IRIG-B signal is distributed via twisted-pair cable, a BNC (male) to binding post adapter can be used. (Pomona 1296, CSI cat. no. BNC-2W)

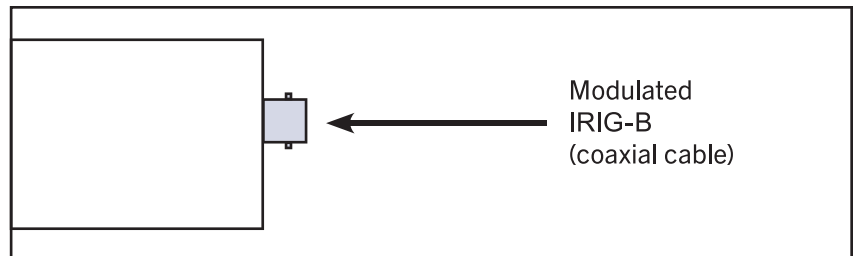

Figure 3-6. IRIG-B input via side BNC connector

COM 1 settings (for HyperTerminal):

- DTE
- 19.2 kbps
- 8 data bits, no parity, 1 stop bit (8N1)

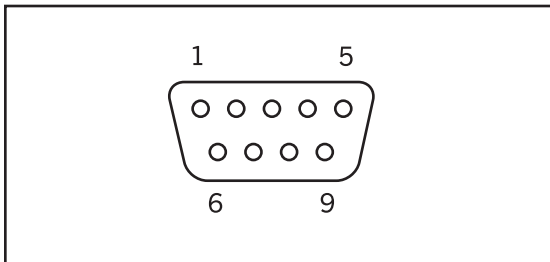

Fig. 3-7. COM 1 configuration port (DB-9)

Configuration Port

The STR-100 and the Acutime GPS antenna can both be configured through the COM 1 port on the STR-100. The connection between the STR and a PC is made using a serial null modem cable. The null modem cable should be connected between the DB-9 (male) connector on the STR and a DB-9 (male) serial port on a PC.

The COM 1 (RS-232, male) port on the STR is configured as DTE, 19.2k baud rate, 8 data bits, no parity, 1 stop bit (8N1)

Table 3-1 – STR COM 1 port (RS-232) pin assignments

Pin number	Description
1	n/c (not connected)
2	Receive data
3	Transmit data
4	n/c
5	Signal ground
6	n/c
7	n/c
8	n/c
9	n/c

Expansion Port

The STR-100 has a DB-15 (female) connector that is designated as an Expansion Port. This port is reserved for future use and is not currently used.

Reset Button

The STR-100 has a reset button that may be used to interrupt normal operation and re-start operation. Use a small instrument such as a paper clip to depress the reset button through the pin hole located on the front of the unit between the two columns of LEDs.

This does not clear any setup values. It also does not reset the GPS antenna.

Another way to reset the STR is to disconnect control power for a few seconds. Note that this method also resets the antenna.

SETUP

Note: The original HyperTerminal utility was licensed by Microsoft to include with Windows. This was discontinued with the release of Windows Vista. Suitable substitutes are available and can be found by searching the Web for “HyperTerminal.” Two such sites:

<http://www.hilgraeve.com/>
<http://www.putty.org/>

Configuring the STR

The STR-100 provides a terminal interface for configuration of the STR and the Acutime smart antenna parameters. The STR user interface can be accessed by connecting a PC running HyperTerminal (or equivalent). Using a null modem cable, connect a PC to the STR-100 COM 1 serial port, and configure HyperTerminal for DTE, 19.2 kbps baud rate, 8 data bits, no parity, 1 stop bit (8N1). When the STR is powered ON or when the unit is RESET, the terminal interface begins execution and runs continually from that point. If a PC running HyperTerminal is properly connected, the prompt “Press ENTER to activate terminal interface.” is displayed on the PC screen. Even if the prompt does not appear, pressing ENTER will bring up the main menu. To exit the terminal interface at any time, press ESC. The terminal interface can be restarted at anytime by pressing ENTER. The terminal interface main menu should look like the following:

```
STR-100, V1.04          12/11/2002      14:49   Trimble
Copyright 2002, Cyber Sciences, Inc., All Rights Reserved

    1 = Set Year (IRIG only)
    2 = Set Local Time Offset
    3 = Set Daylight Saving Time
    4 = Set Parameters to Factory Values
    5 = View parameters
    6 = Watch DCF Output
    7 = Watch GPS Input
    8 = Acutime
    9 = Error Counts
    0 = Set Output Protocol
ESC = Exit

Selection:
```

Figure 4-1. Configuring the STR-100 using HyperTerminal

COM 1 settings (for HyperTerminal):

- DTE
- 19.2 kbps
- 8 data bits, no parity, 1 stop bit (8N1)

The STR-100 main menu displays the STR firmware version number, date, and time on the top line along with the type of GPS source that is currently in use. The data presented on the top line does not automatically update. The actions available to the user are listed along with a selection number. The user should enter the desired number at the “Selection:” prompt and press ENTER. Pressing ENTER without making a selection will refresh the screen with updated values on the top line of the main menu. Pressing ESC will deactivate the terminal interface until ENTER is pressed again. Each item on the menu is explained in the following sections.

Set Year (IRIG Source Only)

This item is used to set the year when IRIG-B is the source of GPS date and time. Since the IRIG-B input frame does not contain a value for year, the STR has to supply it. (If the Acutime GPS antenna is being used, and the user changes the year through this menu item, it will have no effect — the year supplied by the antenna is used instead.) The default value for year is the year of STR-100 manufacture. The year must be in the range 2002 - 2047. If a two-digit number is entered (02 to 47), the STR-100 automatically adds 2000 before validation.

```
Set Year (IRIG only)

Current value of IRIG year: 2002

Enter year (or ESC to exit):
```

Figure 4-2. Set Year (IRIG-B source only)

Set Local Time Offset

This item is used to adjust UTC to local time. The offset is expressed as a positive or negative number of hours and minutes that needs to be added to the GPS time before translation to DCF77. The current offset is displayed, and the user can change it or leave it unchanged by exiting back to the main menu. For example: The local time offset for CST (Central Standard Time) in the USA is -06:00.

```
Set Local Time Offset

The offset is a string containing hours and minutes to be added to or
subtracted from GPS time, giving local time. The format is (s)hh:mm,
where s is an optional sign (+ or -), hh equals hours (00 - 23), and
mm equals minutes (00 - 59)

Examples:
    01:00 - add 1 hour
   +01:00 - add 1 hour
   -01:00 - subtract 1 hour
  -10:30 - subtract 10 hours and 30 minutes
    00:00 - same as no offset

Current offset value: 00:00

Enter offset (or ESC to exit):
```

Figure 4-3. Set Local Time Offset

Set Daylight Saving Time

This item is used to enter setup values for Daylight Saving Time (or Summer Time). A table is provided that contains nine (9) sets of start and stop dates/times that define when an adjustment should be made to UTC time. For example, the nine sets might represent the current year and the next eight years. The current table is displayed and then the command prompt "CMD?" appears at the bottom. The user changes values in the table by entering commands that are documented on the help screen (see below). When the STR is adjusting the time, it searches the Daylight Saving Time table for entries that have been enabled. When it finds an enabled row with a start time less than or equal to the STR time and a stop time greater than the STR time, it adds the offset of that row. The search is in ascending order by row and ends when it finds an offset to add.

Note: All start/stop time values are referenced to "standard time." For example, in the Central Time zone of the USA, Daylight Saving Time begins at 2:00 am CST (Central Standard Time) and ends at 2:00 am CDT (Central Daylight Time). The Daylight Saving Time START time should be entered as 2:00 am (CST) and the STOP time should be entered as 1:00 am (CST).

Note: All start/stop time values are referenced to "standard time." For example, in the Central Time zone of the USA, Daylight Saving Time begins at 2:00 am CST (Central Standard Time) and ends at 2:00 am CDT (Central Daylight Time). The Daylight Saving Time START time should be entered as 2:00 am (CST) and the STOP time should be entered as 1:00 am (CST).

```

Set Daylight Saving Time

      <----- Start -----> <----- Stop -----> Offset   Enabled?
          1
1  00/00/0000  00:00:00  00/00/0000  00:00:00    60     no
2  00/00/0000  00:00:00  00/00/0000  00:00:00    60     no
3  00/00/0000  00:00:00  00/00/0000  00:00:00    60     no
4  00/00/0000  00:00:00  00/00/0000  00:00:00    60     no
5  00/00/0000  00:00:00  00/00/0000  00:00:00    60     no
6  00/00/0000  00:00:00  00/00/0000  00:00:00    60     no
7  00/00/0000  00:00:00  00/00/0000  00:00:00    60     no
8  00/00/0000  00:00:00  00/00/0000  00:00:00    60     no
9  00/00/0000  00:00:00  00/00/0000  00:00:00    60     no

Press ESC to return to main menu, or
enter table update commands ('h' for help).

CMD?

```

Figure 4-4. Set Daylight Saving Time (Summer Time)

Daylight Saving Time - Help Screen

The DST table holds 9 rows of daylight saving time parameters. Each row consists of a start date/time, a stop date/time, and an offset. To set a daylight saving period, fill in the fields of a row and enable the row. Fields are updated using commands containing the field ID and field value. Field ID is the pair of row and column numbers.

Commands operate on a field, a row, or a table.

Substitute row number for 'x', column number for 'y', and date (mm/dd/yyyy), time (hh:mm:ss), or offset (0 - 120) for 'value'.

Enable row:	ex	Ex: Enable row 2.	CMD? e2
Disable row:	dx	Ex: Disable row 3.	CMD? d3
Reset row:	rx	Ex: Reset row 4.	CMD? r4
Reset table:	rt	Ex:	CMD? rt
Set field:	x,y=value		
	Ex: Set start date of period 1.		CMD? 1,1=4/5/2002
	Ex: Set offset of period 3 to 30 min.		CMD? 3,5=30

Press any key to return to 'Set Daylight Saving Time'

Figure 4-5. Daylight Saving Time – Help Screen

Note: As shown on the screen, confirming this action will set (or reset) the channel 2 protocol to DCF77.

Set Parameters to Factory Values

This item sets parameters in the STR-100 back to factory defaults. (Refer to table 4-1 for a summary of all default values.) None of the antenna parameters are affected by this action.

Note: As shown on the screen, confirming this action will set (or reset) the channel 2 protocol to DCF77.

Set Parameters to Factory Values

This function performs the following:

- Sets IRIG year to 2002
- Sets local time offset to zero
- Sets channel 2 protocol to DCF
- Resets daylight saving time table

Confirm? (Y or N)

Figure 4-6. Set Parameters to Factory Values

View Parameters

This menu item displays an overview of all STR-100 setup parameters.

```

View Parameters

    Local Time Offset = 00:00
    IRIG year = 2002
    Channel 1 = DCF (Not selectable)
    Channel 2 = 1 pulse every 10 seconds

Daylight Saving Table:

    <----- Start -----> <----- Stop -----> Offset  Enabled?
      1         2         3         4         5
1  00/00/0000  00:00:00  00/00/0000  00:00:00  60   no
2  00/00/0000  00:00:00  00/00/0000  00:00:00  60   no
3  00/00/0000  00:00:00  00/00/0000  00:00:00  60   no
4  00/00/0000  00:00:00  00/00/0000  00:00:00  60   no
5  00/00/0000  00:00:00  00/00/0000  00:00:00  60   no
6  00/00/0000  00:00:00  00/00/0000  00:00:00  60   no
7  00/00/0000  00:00:00  00/00/0000  00:00:00  60   no
8  00/00/0000  00:00:00  00/00/0000  00:00:00  60   no
9  00/00/0000  00:00:00  00/00/0000  00:00:00  60   no

Press any key to return to main menu.

```

Figure 4-7. View Parameters

Watch DCF Output

This item lets the user see the DCF77 bit stream as it is being transmitted. The last character in the DCF77 frame is displayed as an underline character. The underline character is not actually transmitted. It simply represents the one second pause at the end of a frame (part of the DCF77 protocol). Most of the time the first line of DCF output will be a partial frame, because the menu item was selected at a random time rather than exactly at the top of a minute. The date and time values displayed at the end of each line are after all adjustments (local offset and Daylight Saving Time) have been made. The display is terminated by pressing ESC at any time.

```

Press ESC to return to main menu
00000000000001011010011010101000010001100000100000000 _ Thu 01/10/02 15:16
0000000000000000000000000111101000101010100001000110000010000000 _ Thu 01/10/02 15:17
0000000000000000000000000100011000101010100001000110000010000000 _ Thu 01/10/02 15:18
0000000000000000000000000110011001101010100001000110000010000000 _ Thu 01/10/02 15:19

```

Figure 4-8. Watch DCF77 Output

Watch GPS Input

This item lets the user see the date, time, and day of week every second. The values for date and time on this screen have not been adjusted by local offset or Daylight Saving Time. The display is terminated by pressing ESC at any time.

```

Press ESC to return to main menu

Thu 01/10/2002 15:42:09
Thu 01/10/2002 15:42:10
Thu 01/10/2002 15:42:11
Thu 01/10/2002 15:42:12
Thu 01/10/2002 15:42:13
Thu 01/10/2002 15:42:14
Thu 01/10/2002 15:42:15
Thu 01/10/2002 15:42:16
Thu 01/10/2002 15:42:17
Thu 01/10/2002 15:42:18
Thu 01/10/2002 15:42:19
Thu 01/10/2002 15:42:20

```

Figure 4-9. Watch GPS Input

Acutime

This item will display the Acutime GPS antenna main menu that is used to view or set the antenna parameters. The four menu items allow the user to display the antenna status screen, set self-survey parameters, perform a self-survey, and to set the Acutime antenna back to its initial state as shipped from the factory. These menu options provide the user the ability to configure the antenna parameters through the STR. A screen shot of each of the Acutime menu items is included in this section.

```

Acutime Main Menu

    1 = View Status
    2 = Set Self-Survey Parameters
    3 = Perform Self-Survey
    4 = Factory Reset
    ESC = Exit

Selection:

```

Figure 4-10. Acutime Main Menu

The View Status screen provides detailed, read-only, access to critical parameters within the Acutime GPS antenna. These parameters include the configuration of the self-survey parameters as well information such as position, operating mode, antenna status, and the number of satellites seen by the antenna.

```

Acutime - View Status          01/10/2002    16:22:05

  Self-survey enabled: Y
Save position enabled: Y
  Self-survey length: 600
    PPS output: Y
Self-survey progress: 100%
  Latitude: 35.893390 deg    35o 53' 36"
  Longitude: -86.396553 deg  -86o 23' 48"
  Altitude: 163.43 meters
  Receiver mode: Overdetermined Clock
GPS decoding status: Doing fixes
Acquired satellites: 8
  Minor alarm: Almanac

Press ESC to exit or any key to continue.

```

Figure 4-11. Acutime – View Status

The Set Survey Parameters screen allows the user to set the sample size that the antenna will use in fixing its location. It is recommended that the survey size be set to a value of 600 (default value is 2000). This typically reduces the start-up time from about 40 minutes to about 10 minutes.

```

Acutime - Set Survey Parameters

```

```

This function enables self-survey, turns on the save position flag,
and sets the survey size. Survey size must be in the range 100 - 3000.
The default factory value is 2000, and the recommended value is 600 for
quicker surveys.

```

```

Enter survey size (or ESC to exit):

```

Figure 4-12. Acutime – Set Survey Parameters

The Perform Self-Survey menu allows the user to direct the antenna to perform a self-survey now. This might be used in a case where the antenna was moved, and a new position needs to be calculated.

```

Acutime - Perform Self-Survey

```

```

This function instructs the Acutime to perform a self-survey.

```

```

Start self-survey? (Y or N)

```

Figure 4-13. Acutime – Perform Self-Survey

The Factory Reset option provides the ability to clear the antenna's programming, returning the antenna to its initial 'non-configured' state. Performing this reset is **NOT RECOMMENDED!** This reset will prevent the Acutime antenna from functioning properly, and will require the antenna be returned to Cyber Sciences for re-programming.

```
Acutime - Factory Reset
```

```
This function instructs the Acutime to perform a factory reset.
```

```
Perform factory reset? (Y or N)
```

Figure 1-2. STR-100 front view (with connectors removed)

Error Counts

This item is used primarily for troubleshooting. Certain useful counters are displayed, and the user is given an opportunity to set them back to zero. These same counters are also set to zero on power up or STR reset. It's not unusual for these counters to have non-zero values during normal operation of the STR.

```
Error Counts
```

```
Costate terminations by watchdog = 2  
  Invalid IRIG pulse counts = 0  
    DCF frame aborts = 3  
      Invalid DCF time = 0
```

```
Enter 'R' to reset counters (or press ESC to exit):
```

Figure 4-15. Error Counts

Set Output Protocol

The output protocol of channel 2 is user-selectable. After option 0 is selected, the following new screen appears. It shows the current configuration of both channels. Channel 1 is always DCF, and channel 2 can be either DCF or 1per10. The user will enter '1' to configure channel 2 as DCF or enter '2' to configure channel 2 for 1per10. The entry made by the user is saved in non-volatile memory and persists through power interruptions.

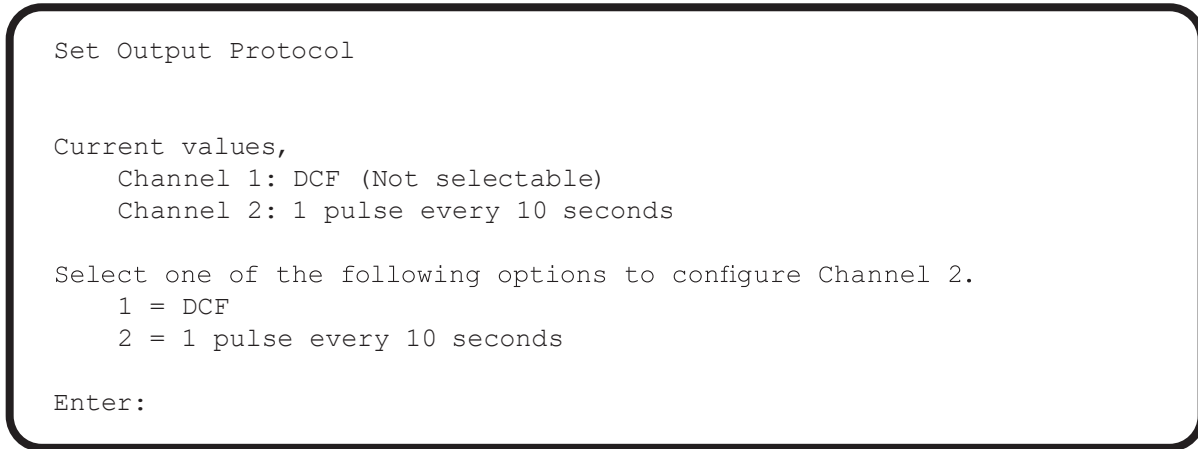

Figure 4-16. Set Output Protocol

Summary of all Default Values

Depending on the application, it may not be necessary to change the default settings of the STR-100. The table below summarizes the default values of all parameters of both the STR and the Acutime GPS antenna (if used).

Table 4-1 – Summary of Default Values

Parameter	Description	Available Values	Default
IRIG year	Current year, 4 digits (IRIG-B source only).	2002 to 2047	year of mfr.
Local time offset	Offset in hours and minutes from UTC (+/- hh:mm).	-23:59 to +23:59	00:00
Daylight Saving Time (DST) table	DST start/stop dates/times and time offset values (table of up to 9 entries).	start/stop: mm/dd/yy hh:mm offset: 0 to 120 min.	none (no DST adjustment)
Channel 2 protocol	Selects time protocol output for channel 2.	DCF77 or 1per10	DCF77
Acutime survey size	Acutime GPS antenna survey size. (For faster restoration after power loss, it is recommended to set this to 600.)	100 to 3000	2000

OPERATION

Normal Operation

When the STR-100 is powered up, it searches for a valid GPS data source. If an Acutime antenna signal is not detected, the STR continues checking for an IRIG-B signal. If neither signal is detected, it continues to check for each type of source until one is detected.

Once a valid GPS signal is detected, whether Acutime or IRIG-B, the STR functions in its normal state, continuously generating DCF77 output signals. The STR captures the date and time each second, and outputs the DCF77 date and time beginning at the top of each minute. If channel 2 is configured for 1per10, then the STR also outputs one sync pulse every 10 seconds on this channel.

If the GPS input signal is lost, the STR will stop generating DCF77 outputs and wait for the input source to come back. Once a valid GPS signal is detected, the STR returns to normal operation.

Indicator LEDs

The STR-100 includes indicator LEDs to confirm normal operation or aid in troubleshooting in the event of wiring errors or lost GPS signal. On power-up, the SYNC LED is off and the STAT LED flashes twice repeatedly until a valid GPS signal is detected. Once a signal is detected, the SYNC LED is on steady. If the input signal is lost, the SYNC LED is turned off until the signal is captured again.

During normal operations, the SYNC LED remains on, and the STAT LED flashes repeatedly according to the type of receiver: three blinks for IRIG-B, and four blinks for Acutime. The DCF LED flashes once per second in sync with the DCF77 pulse output. The CH 1 and CH 2 error LEDs only flash if there is a problem with their respective loads.

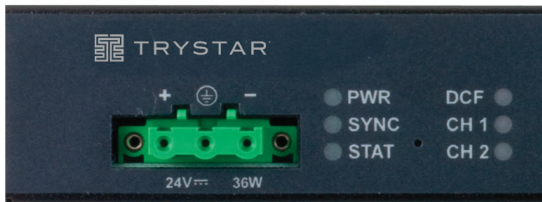

Fig. 5-1. Indicator LEDs (STR front-left)

Table 5-1 – STR-100 Indicator LEDs

LED	Color	Description	Indication	Normal
PWR	Green	Power on	On steady — normal operation (24Vdc control power present) Off — no control power	On
SYNC	Green	GPS sync	On steady — Valid GPS input (Acutime or IRIG-B) detected Off — no GPS input	On
STAT	Green	GPS status	Flashes twice, repeatedly — checking for valid GPS input Flashes 3 times, repeatedly — IRIG-B time signal in use Flashes 4 times, repeatedly — Acutime time signal in use Off — no signal	Flashing
DCF	Green	DCF output	Flashing once per second — normal operation (confirms DCF77 output) Off — not yet generating time sync output	Flashing
CH 1	Red	Channel 1 error	Off — normal operation Flashing — Error: Channel 1 overload	Off
CH 2	Red	Channel 2 error	Off — normal operation Flashing — Error: Channel 2 overload	Off

SPECIFICATIONS

ELECTRICAL	
Control power	
• Voltage ^①	24Vdc, nominal (sourced from Class 2 rated power supply)
• Burden, maximum ^②	36 watts
• Isolation	1.5 kV
GPS antenna interface	
• Compatible “smart antennas”	Trimble Acutime 360 GPS smart antenna
• Antenna interface signal input to STR	RS-422 (12-conductor)
IRIG-B input (Modulated)	
• Time code	Amplitude-modulated IRIG-B (Codes B120 to B123)
• Carrier	1 kHz
• Amplitude	0.5 to 10.0 Volts peak–peak
• Input impedance	4000 ohms, transformer-isolated
DCF77 output (or 1per10)	
• Voltage range	11 to 28 Vdc (depends on control voltage input)
• Output current	500 mA, max.
• Pulse rate (per DCF77 standard)	1 pulse-per-second (1PPS), accuracy = +/- 50 microseconds
MECHANICAL	
Mounting	Standard DIN rail or panel/wall mount or surface placement
Dimensions (W x H x D)	7.92 x 1.50 x 4.81 inches (201 x 38 x 122 mm)
Weight	1.5 lbs. (0.68 kg)
ENVIRONMENTAL	
Operating temperature	-30 to +80 C
Storage temperature	-40 to +85 C
Humidity rating	5% to 95% relative humidity (non-condensing) at +40 C
Pollution degree class	Class 2
REGULATORY / STANDARDS COMPLIANCE	
USA	UL listed (UL-508)
Canada	cUL (CSA C22.2)
Europe	CE mark
Electromagnetic interference / immunity	
• Radiated emissions	EN 55022 / FCC class A
• Conducted emissions	EN 55022 / FCC class A
• Immunity for industrial environments	EN 61000-6-2
• Electrostatic discharge (air discharge)	EN 61000-4-2
• Immunity to surge (impulse wave)	EN 61000-4-5
• Immunity to electrical fast transients	EN 61000-4-4
• Power frequency magnetic field	EN 61000-4-8
• Voltage dips / voltage interruptions	EN 61000-4-11
• Conducted immunity	EN 61000-4-6
• Radiated immunity	EN 61000-4-3

1. The STR-100 is designed to operate properly on any voltage between 11 and 28 Vdc. Whatever voltage is supplied will be the same as the output on the two DCF77 outputs.
2. The maximum burden is largely a function of the load imposed on the two DCF77 outputs. The typical burden of the device with the Acutime antenna connected, but without any DCF77 connection, is 4 watts at 24Vdc.

FREQUENTLY ASKED QUESTIONS (FAQS)

Q. Does the STR-100 require a HyperTerminal connection in order to run?

A. No. The STR can operate without a HyperTerminal connection. HyperTerminal is used only to change STR setup parameters from their default values, as desired.

Q. Which models of Acutime GPS antenna are compatible with the STR-100?

A. The STR has been tested with the Trimble Acutime 360 GPS smart antenna, as well as its predecessors, Acutime Gold and 2000.

Q. Can IRIG-B and Acutime GPS antenna sources both be connected to the STR-100?

A. Yes. The STR looks for the Acutime antenna first. Therefore, when both sources are connected and functioning, the antenna will be selected when the STR starts up. If the antenna is not outputting its PPS (pulse per second) signal when the STR is powered up or reset, then the IRIG-B source would be selected.

Q. Do I have to reset STR parameters after a power loss?

A. No. The STR parameters are stored in non-volatile memory.

Q. Is there an adapter I can use to connect an IRIG-B signal to the STR using twisted pair cable instead of coax?

A. Yes. Pomona makes a BNC-to-screw-terminals adapter that is compatible with the STR. The Pomona part number is 1296 and can be purchased from many electronics distributors. It can also be purchased from Trystar (CSI part number BNC-2W).

Q. Do I have to reset the Acutime antenna parameters after a power loss?

A. No. When antenna parameters are changed through the STR, the antenna is instructed to store the parameters in EEPROM.

Q. Why does the STR-100 sometimes stop generating DCF77 outputs when there has been no power loss?

A. There is a watchdog timer that goes off when the input signal is lost for approximately five seconds. This could happen, for example, when the antenna doesn't have a fix on at least one satellite.

Q. How long does it take the STR-100 to become operational after a power on or reset?

- A. It usually takes just a few minutes. In most cases, the STR will start generating the DCF77 output signal at the top of the next minute following synchronization with a GPS source.

Q. If I am using an Acutime antenna as the GPS source, do I need to set the year in the terminal interface?

- A. No. The STR gets the year from the antenna. The year setup parameter is used only with IRIG-B input.

Q. Do I need to set the local time offset and the Daylight Saving Time table?

- A. No. The STR will send UTC time without these adjustments in the output DCF77 frame.

Q. Why would I ever need to change the Acutime antenna self-survey parameters?

- A. You would configure them if you want the antenna to come up quickly after a power loss. The recommended value of 600 will allow the antenna to synchronize about three to four times faster than the factory default of 2000. Setting the self-survey parameters instructs the antenna to store its position in EEPROM. On power up it will use the stored position instead of doing a lengthy self-survey.

Q. If I use IRIG-B for GPS input, do I have to re-enter the year on every New Year's Day?

- A. No. The STR automatically updates the year during the first second of the new year, provided it is powered-on and operational at that time.

Q. When I enter time values into the Daylight Saving Time table, do I use Standard Time or Daylight Time values?

- A. Standard Time values for both entries. For example, if Daylight Saving Time starts at 2:00 a.m. US CST and ends at 2:00 a.m. CDT, then the start time would be entered as 2:00:00 and the stop time as 1:00:00.

Q. Why is the PowerLogic circuit monitor not obtaining the correct time, even though the STR's DCF LED is on?

- A. If the circuit monitor is set to a value for "present year" that differs from that sent in the output DCF77 frame, the circuit monitor does not accept the time synchronization. Verify the correct year is stored in the circuit monitor. If the STR's DCF LED blinks once per second, then the problem is probably a result of circuit monitor setup or wiring error.

NOTES

