

Satellite Time Reference STR-100/IRIG-B



The Trystar Satellite Time Reference STR-100/IRIG-B accepts a Global Positioning System (GPS) time signal from a Trimble Acutime 360 GPS smart antenna and outputs a precision time reference in unmodulated IRIG-B format.

The STR-100/IRIG-B can be distinguished from base model STR-100 units by the presence of an additional label on the front of the device, which clearly indicates that the IRIG-B output option is installed. This label is positioned above the 4-position connector on the front of the STR-100 (the connector labeled “DCF OUT” on the standard model), and reads “IRIG-B Output Option Installed”. In addition, the BNC connector on the right side of the STR-100 is labeled “IRIG-B Out.”

SAFETY PRECAUTIONS



HAZARD OF ELECTRIC SHOCK, EXPLOSION, OR ARC FLASH

- Only qualified workers should install this equipment. Such work should be performed only after reading this entire set of instructions.
- NEVER work alone.
- Before performing visual inspections, tests, or maintenance on this equipment, disconnect all sources of electric power. Assume that all circuits are live until they have been completely de-energized, tested, and tagged. Pay particular attention to the design of the power system. Consider all sources of power, including the possibility of backfeeding.
- Apply appropriate personal protective equipment (PPE) and follow safe electrical practices. For example, in the USA, see NFPA 70E.
- Turn off all power supplying the equipment in which the device is to be installed before installing and wiring the device.
- Always use a properly rated voltage sensing device to confirm that power is off.
- Beware of potential hazards, wear personal protective equipment, and carefully inspect the work area for tools and objects that may have been left inside the equipment.
- The successful operation of this equipment depends upon proper handling, installation, and operation. Neglecting fundamental installation requirements may lead to personal injury as well as damage to electrical equipment or other property.

Failure to follow these instructions can result in death or serious injury.

IMPORTANT:

This bulletin supplements the base model STR-100 Owners Manual, 0516IB0326. Refer to this document for basic mounting, wiring and setup.

If the IRIG-B Distribution Module (IDM) is also used, refer to the instruction bulletin for this device, doc. 0517IB0326.

WIRING

With the IRIG-B option installed, two of the STR-100 connectors have new functions:

1. The BNC connector used for (modulated) IRIG-B input on the STR 100 base model is instead used for (unmodulated) IRIG-B output on the STR-100/IRIG-B. The output signal level on this interface is TTL compatible (5Vdc nominal), which is the most common implementation of unmodulated IRIG-B. IRIG-B-compatible devices can be connected directly to this interface according to the drive capabilities listed in the specifications section.
2. The four position connector used for DCF77 output on the base model is instead used for distributing the IRIG-B signal at 24Vdc nominal, along with 24Vdc control power, to one or more STR IRIG-B Distribution Modules (STR-IDM). This enables the STR to supply IRIG-B signals to many devices across long distances. The STR-IDM also provides complete electrical isolation at each point of service.

Connectors



STR-100/IRIG-B side view



STR-100/IRIG-B front view (close-up)

! WARNING !

The signal levels on this (front) interface are not standard IRIG-B-compatible. Do not connect any IRIG-B device directly to this interface as damage to the device may result. This connector uses 24Vdc signal levels and control power to enable multi-point topology over long distances. This is connected to one or more STR-IDM devices, which in turn distribute the IRIG-B signal at the more common 5Vdc nominal.

Direct Wiring of IRIG-B Signal

If only a few IRIG-B devices are being driven then they can be connected directly to the BNC connector on the side of the STR-100. The exact number that can be driven depends on the load imposed by each device and the cable type and distance. The cable employed can be 75 ohm coaxial cable or twisted pair cable provided the correct BNC to twisted pair adapter is used. This configuration is shown below.

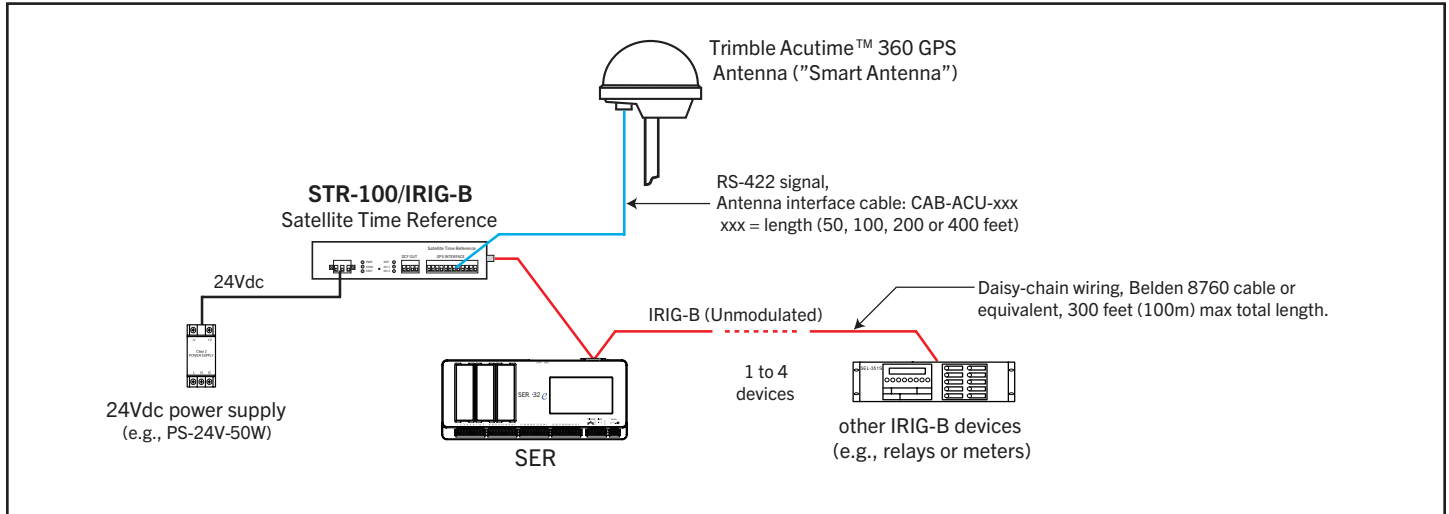

GPS system architecture showing STR-100/IRIG-B with direct IRIG-B time sync output signal

Multi-point Wiring of IRIG-B Signal

The optional STR-IDM allows multi-point wiring of the IRIG-B signal as shown below. Typically, IRIG-B signals must be wired point-topoint. The IDM greatly simplifies wiring of IRIG-B devices by allowing distribution of the IRIG-B time signal over multi-point communications and across longer distances.

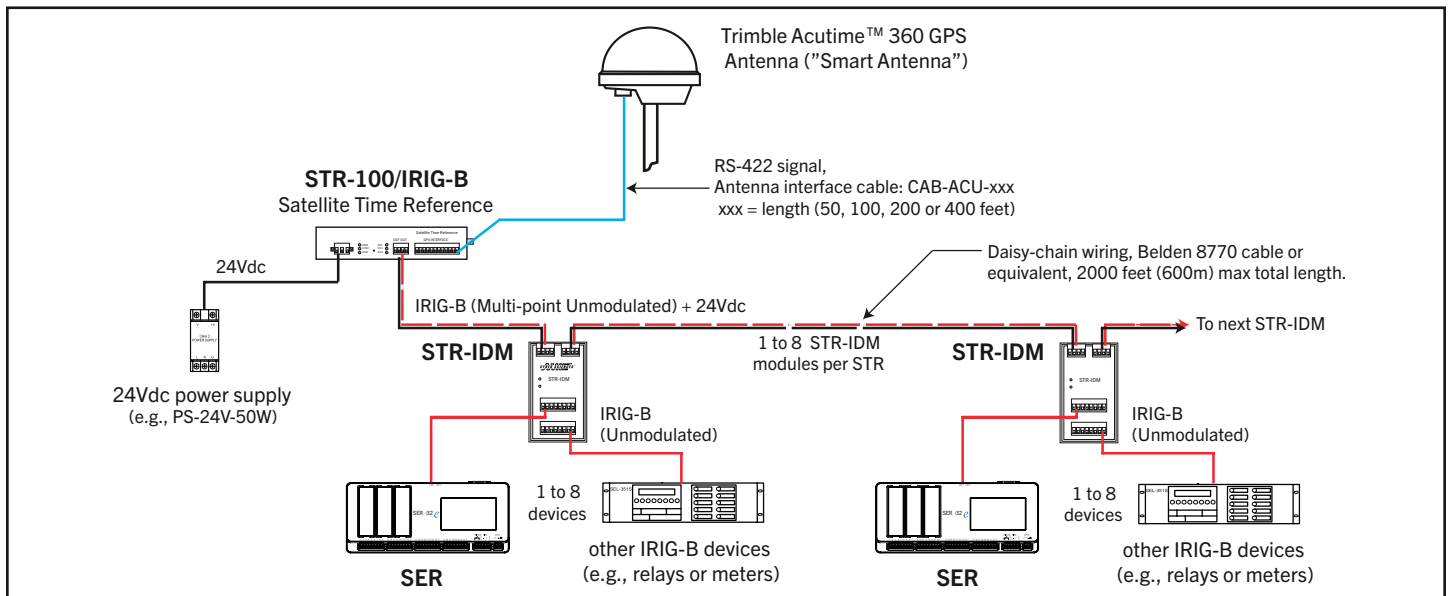

GPS system architecture showing STR-100/IRIG-B with multi-point distribution of IRIG-B time sync signals using the IDM

STR-100/IRIG-B Multi-point Output

Each STR-IDM has two identical 4 position connectors making it easy to daisy-chain connections to multiple STR-IDMs from the STR-100. The STR-IDM output connectors are defined as follows. The colors suggested are for Belden 8770 cable.

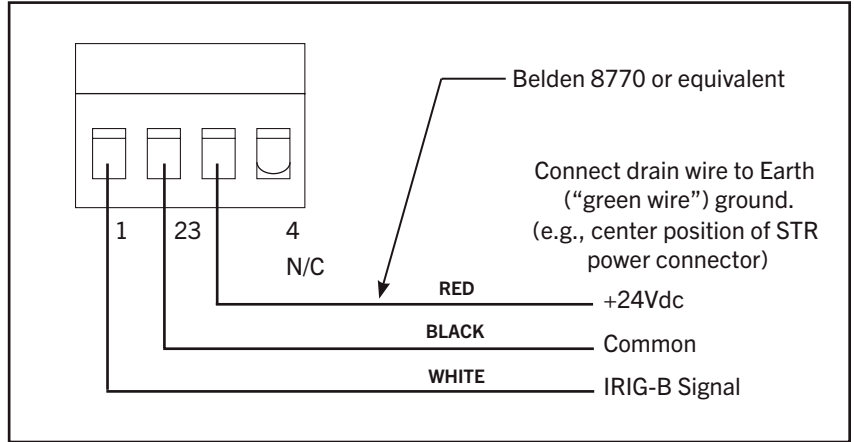

STR-100/IRIG-B Multi-point IRIG-B Output Connections

STR-IDM Wiring

Each STR-IDM has two identical 4 position connectors making it easy to daisy-chain connections to multiple STR-IDMs from the STR-100. The multi-point IRIG-B input wiring for the STR-IDM is shown below. Refer to the IDM instruction bulletin (document number IB-IDM-01) for complete information.

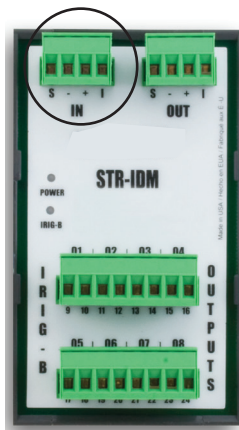

STR-IDM front view

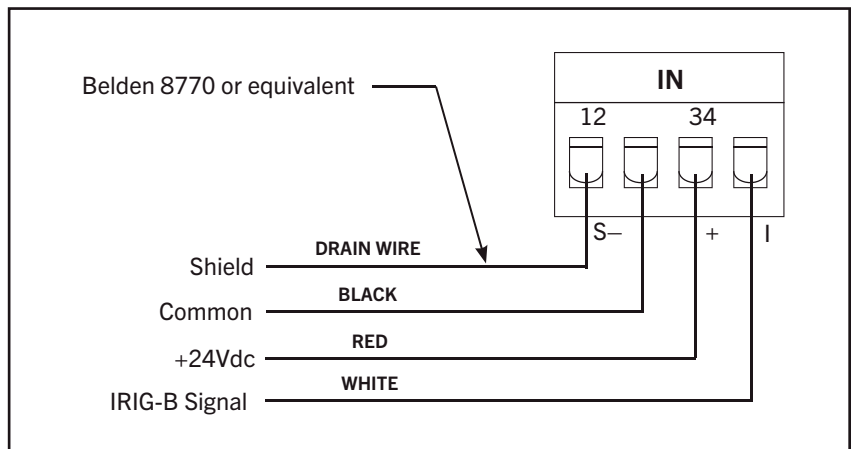

STR-IDM Multi-point IRIG-B Input Connections



STR-100/IRIG-B side view

Note: Most setup options are the same as those of the base model STR-100. However, one item is unique to the STR 100/IRIG-B and **MUST** be changed for proper operation:
> 8: Acutime > 5: Set Satellite Threshold.

SETUP

The STR-100/IRIG-B provides a terminal interface for configuration, very similar to the base model STR-100 and described in detail in the STR-100 instruction bulletin (IB-STR-01). The STR user interface is accessed by connecting a PC running HyperTerminal (or equivalent). Using a null modem cable, connect a PC to the STR COM 1 serial port, and configure HyperTerminal for 19200bps, 8 bits, no parity, 1 stop bit.

When the STR is powered ON or when the unit is RESET, the terminal interface begins execution and runs continually from that point. If a PC running HyperTerminal is properly connected, the prompt “Press ENTER to activate terminal interface.” is displayed on the PC screen. Even if the prompt does not appear, pressing ENTER will bring up the main menu. To exit the terminal interface at any time, press ESC. The terminal interface can be restarted at anytime by pressing ENTER.

The STR-100/IRIG-B main menu displays the STR firmware version number, date, and time on the top line along with the status of GPS source. The data presented on the top line does not automatically update. The actions available to the user are listed along with a selection number. Enter the desired number at the “Selection:” prompt and press ENTER. Pressing ENTER without making a selection will refresh the screen with updated values on the top line of the main menu. Pressing ESC will deactivate the terminal interface until ENTER is pressed again.

While most STR-100/IRIG-B setup choices are optional, one change to the default settings of the Acutime 360 antenna is required to ensure proper IRIG-B output and reliable interoperability with some IRIG-B devices.

The STR-100/IRIG-B main menu is shown below:

Main Menu

```
STR-100/OEM/IRIG-B/B007, V1.10          07/01/2011      14:49   Trimble  
Copyright 2002-2011, Cyber Sciences, Inc., All Rights Reserved
```

```
1 = Reserved  
2 = Set Local Time Offset  
3 = Set Daylight Saving Time  
4 = Set Parameters to Factory Values  
5 = View parameters  
6 = Reserved  
7 = Watch GPS Input  
8 = Acutime  
9 = Error Counts  
ESC = Exit
```

```
Selection: _
```

Configuring the STR-100/IRIG-B using HyperTerminal

Acutime

This item displays the Acutime GPS antenna main menu, used to view or set the antenna parameters. These menu options allow the user to configure the antenna parameters via the STR. The first four (4) items are optional, and more details are provided in the main STR-100 instruction bulletin.

The fifth item, Set Satellite Threshold, must be changed for proper operation with IRIG-B devices, as described in the next section.

```

Acutime Main Menu

      1 = View Status
      2 = Set Self-Survey Parameters
      3 = Perform Self-Survey
      4 = Factory Reset
      5 = Set Satellite Threshold
      ESC = Exit

Selection: _

```

STR-100/IRIG-B Option 8: Acutime Main Menu

The Set Satellite Threshold screen allows the user to set the minimum number of usable satellites required to initiate or maintain the GPS antenna's PPS (pulse per second) signal to the STR-100/IRIG-B. The default value is 3, but this setting must be changed to 0 for proper operation.

Acutime - Set Satellite Threshold

This function sets the minimum number of usable satellites that must be acquired before the PPS will be generated. Since IRIG-B output depends on PPS, this function determines the minimum number of satellites required to generate IRIG-B output.

**CHANGE THIS
TO "0"**

Enter minimum number of satellites (0, 1, or 3): _

STR-100/IRIG-B Menu Option 8: Acutime—Set Satellite Threshold

OPERATION

During normal operation, the green LEDs marked PWR and SYNC remain on steady. The LED marked IRIG-B will appear to "flicker" at a high rate confirming IRIG-B data is being output. This is normal and reflects the high pulse rate (1 kHz) of the IRIG-B signal.



STR-100/IRIG-B front view (close-up)

TECHNICAL SPECIFICATIONS

SPECIFICATIONS	
<p>Unmodulated IRIG-B output</p>	<p>The IRIG-B output conforms to IRIG-B (type B007):</p> <ul style="list-style-type: none"> • Format B, 100 PPS (pulses-per-second) • 0 = unmodulated (DC level shift, pulse-width coded) • 0 = no carrier • 7 = BCD coded expressions (time of year, year), SBS
<p>Direct IRIG-B output (BNC on side)</p>	<p>TTL-level signals (5Vdc nominal):</p> <p>V_{low} (max. voltage for logical "0") = 0.4 volts @ 24 mA</p> <p>V_{high} (min. voltage for logical "1") = 3.2 volts @ -15 mA</p>
<p>Multi-point IRIG-B output (front)</p>	<p>24Vdc nominal signals + 24Vdc control power (for distribution to STR-IDM)</p>
<p>Power requirements</p>	<p>24 Vdc (nominal), sourced by a class 2 rated supply. Burden of 36 watts max, depending on output loading. Typical no-load power consumption is 4 watts.</p>

