

TRYSTAR
SEQUENCE OF EVENTS
RECORDER
SER-32e



TABLE OF CONTENTS



INTRODUCTION	3
PRODUCT OVERVIEW	3
BENEFITS	5
KEY FEATURES	6
ORDERING INFORMATION	7
PTP (IEEE 1588) OPTION	7
INSTALLATION	8
DIMENSIONS	8
MOUNTING CONSIDERATIONS	8
DIN-RAIL MOUNTING	9
WIRING	10
WIRING CONNECTIONS	10
DIGITAL INPUTS	11
CONTROL POWER	12
TIME SYNC (PTP MASTER OR SLAVE)	12
TIME SYNC IN (IRIG-B OR DCF77)	13
TIME SYNC OUT (IRIG-B, DCF77 OR 1PER10)	13
RS-485 TIME SYNC IN/OUT	14
TRIGGER OUTPUT (TO ONE OR MORE DEVICES)	14
OPERATION	15
LOCAL DISPLAY AND KEYPAD	15
LCD MENU STRUCTURE	15
INITIAL SETUP VIA LCD/KEYPAD	16
SETUP (WEB SERVER)	17
INITIAL SETUP VIA WEB PAGE (DIRECT-CONNECT)	17

SETUP VIA WEB PAGE (OVER A NETWORK)-----	18
COMMUNICATIONS SETUP-----	19
TIME SETUP -----	21
INPUTS SETUP -----	23
GROUPS SETUP -----	25
ADMINISTRATION SETUP-----	26
ALTERNATE SETUP: EDITING XML FILE -----	26
HTTPS- -----	27
MONITORING (WEB SERVER)-----	28
MONITORING: STATUS -----	28
DATA PAGE (COUNTERS)-----	29
RESETS PAGE-----	29
EVENTS PAGE-----	29
CONTROL: TEST -----	31
DIAGNOSTICS PAGE-----	32
CONTROL POWER RIDE-THRU MODULE -----	33
REAL-TIME CLOCK BATTERY BACK-UP STATUS	33
PRODUCT SPECIFICATIONS-----	35
INCLUDED SOFTWARE LICENSES -----	37

SAFETY PRECAUTIONS

Note: Electrical equipment should be serviced by qualified personnel. No responsibility is assumed by Trystar, for any consequences arising out of the use of this material. This document is not intended as an instruction manual for untrained persons.

Important safety precautions must be followed before attempting to install, service, or maintain electrical equipment. Carefully read and follow the safety precautions outlined below.

NOTE: Electrical equipment should be serviced by qualified personnel. No responsibility is assumed by Trystar, for any consequences arising out of the use of this material. This document is not intended as an instruction manual for untrained persons.

DANGER

HAZARD OF ELECTRIC SHOCK, EXPLOSION, OR ARC FLASH

- Only qualified workers should install this equipment. Such work should be performed only after reading this entire set of instructions.
- NEVER work alone.
- Before performing visual inspections, tests, or maintenance on this equipment, disconnect all sources of electric power. Assume that all circuits are live until they have been completely de-energized, tested, and tagged. Pay particular attention to the design of the power system. Consider all sources of power, including the possibility of backfeeding.
- Apply appropriate personal protective equipment (PPE) and follow safe electrical practices. For example, in the USA, see NFPA 70E.
- Turn off all power supplying the equipment in which the device is to be installed before installing and wiring the device.
- Always use a properly rated voltage sensing device to confirm that power is off.
- Beware of potential hazards, wear personal protective equipment, and carefully inspect the work area for tools and objects that may have been left inside the equipment.
- The successful operation of this equipment depends upon proper handling, installation, and operation. Neglecting fundamental installation requirements may lead to personal injury as well as damage to electrical equipment or other property.

Failure to follow these instructions can result in death or serious injury.

NOTICE

FCC (Federal Communications Commission)

This equipment has been tested and found to comply with the limits for a Class A digital device, pursuant to part 15 of the FCC Rules. These limits are designed to provide reasonable protection against harmful interference when the equipment is operated in a commercial environment. This equipment generates, uses and can radiate radio frequency energy and, if not installed and used in accordance with the instruction manual, may cause harmful interference to radio communications. Operation of this equipment in a residential area is likely to cause harmful interference in which case the user will be required to correct the interference at his own expense. The user is cautioned that any changes or modifications not expressly approved by Trystar may void the user's authority to operate the equipment.

The Class A digital apparatus complies with CISPR 11, Class A, Group 1 (EN 55011) and Canadian ICES-003. (EN 61326-1) L'appareil numérique de classe A est conforme aux normes CISPR 11, classe A, groupe 1 (EN 55011) et à la norme Canadienne ICES-003. (EN 61326-1)

Open source software components

This Trystar device is provided with certain open source software components (collectively, "OSS") developed by third parties. Refer to the section on "Included Software Licenses". (Section 8 of this document)

INTRODUCTION

Product Overview

The Trystar Sequence of Events Recorder provides precise time-stamped event reporting for 32 channels to enable root-cause analysis and advanced system diagnostics.

Configurable event recording: Each input is individually configurable with digital filter, debounce and contact chatter functions to ensure reliable operation.

Event log: The Trystar SER records the date and time associated with all state changes to one (1) millisecond and stores up to 8192 events in non-volatile memory. Each event record contains the date/time stamp, event type, channel number and state, time quality, and unique sequence number.

Export events to Comma Separated Variable (CSV): An export button allows the user to save event data to a CSV file for further analysis in Excel® or other software.

EPSS data log groups: Inputs can be assigned to a group for data logging purposes. If any input in a group changes state, then the states of all group members are recorded in its EPSS data log. This enables specialized reporting for mandatory tests of emergency power supply systems (EPSS) to document compliance with standards for healthcare and other critical-power facilities.

Operations counters: Operations counters are maintained for all 32 channels (inputs), with date/time of last reset. Each channel can be reset individually.

Ethernet communications: Network data communications to a host system are supported via 10/100BaseTx Ethernet using Modbus TCP and/or RESTful web service. The device also features an embedded secure web server to simplify setup, operation, firmware updates and file transfers. In addition, PTP (Precision Time Protocol (IEEE 1588) or NTP (Network Time Protocol) can be used for time synchronization over Ethernet.

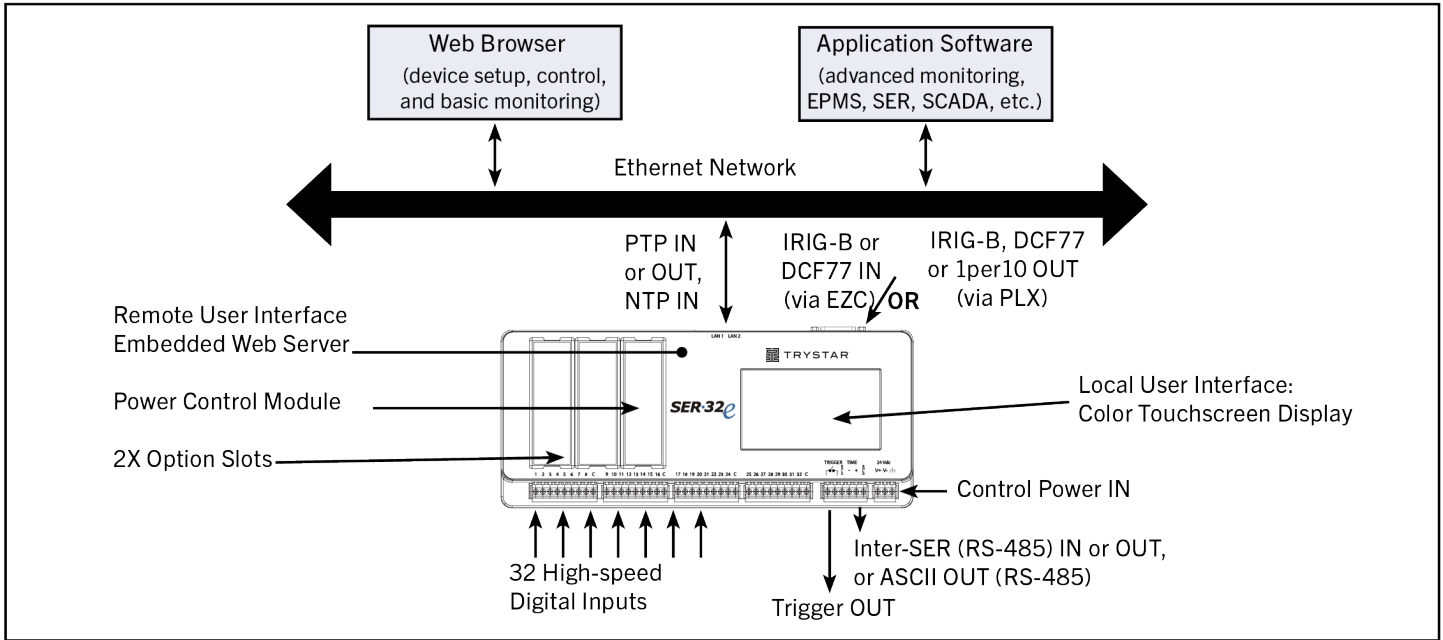

Figure 1-1. Trystar Sequence of Events Recorder SER-32e product overview

- Status monitoring examples:**
- Breaker status: open/closed/tripped
 - Breaker control switch: open/close commands
 - Relay trip signal: normal/trip
 - Auto-transfer switch (ATS) status: normal/emergency/test
 - Control scheme status: auto/manual/test
 - UPS status: normal/bypass
 - Generator status: stopped/running
 - Battery status: normal/alarm

Time synchronization (PTP). High-resolution time sync (100 μ s) is supported using PTP (Precision Time Protocol, per IEEE 1588) over the Ethernet network used for data communications. (Timestamps \pm 0.5 ms.) The SER-32e can be configured as the PTP master (grandmaster clock for all other SERs and PTP-compatible devices) or a PTP slave, synchronized to a PTP grandmaster (another SER or third-party clock).

Time synchronization (other protocols). Hi-res time sync (100 μ s) using legacy protocols such as ‘IRIG-B (unmodulated) or DCF77’ is also supported. (Timestamps \pm 0.5 ms.) NTP or Modbus TCP time-sync are supported, but accuracy depends on network design and is typically \pm 100 ms or more.

Time-sync master. One SER can serve as a time-sync master to other devices via PTP or an RS-485 subnet. RS-485 serial protocol is either IRIG-B or DCF77 (per the input time source) or ASCII (selectable). When PTP or NTP is the time source, an SER can output IRIG-B, DCF77 or 1per10 using an optional interface (PLX-5V or PLX-24V).

Trigger output. Any input can be configured to close a high-speed output contact to trigger an associated action, such as a power meter’s capture of voltage and current waveforms coincident with an event. The trigger occurs in the same millisecond interval during which the event is detected, with no filtering applied.

Multiple Modbus masters. The SER supports data access from multiple Modbus TCP masters (up to 44 simultaneous Modbus connections). This enables integration of multiple systems and flexibility in how application software manages sockets.

Settings stored in non-volatile memory. All settings are stored in non-volatile flash memory in XML file format. Configuration is accomplished using a standard web browser, or by modifying the setup file directly (by advanced users).

Benefits

Benefits for end users, system integrators and OEMs include:

Time-critical information for root-cause analysis (1 ms)

Time-stamped record of events—up to 8192 events stored in non-volatile memory.

Reliable event recording with “zero blind-time”

Event-recording engine records all events, even those occurring in rapid succession.

Advanced troubleshooting

High-speed trigger output to capture waveforms by a compatible power meter.

Simple setup using a web browser—no proprietary software

Embedded web server hosts user-friendly pages for setup and monitoring.

No maintenance required

Event data and user setup data is stored in non-volatile flash memory.

Easy system integration

Integrate with multiple systems via Ethernet: Modbus TCP, RESTful API and secure web interface.

Flexible time synchronization choices

PTP, IRIG-B, DCF77, NTP, Modbus TCP or SER inter-device (RS-485).

EPSS generator test-compliance reports enabled

16 data logs: when any group member changes state, all members' states are recorded.

Easy replacement

If a unit ever needs to be replaced, settings are transferable via XML setup file

Regulatory approvals to global standards

UL-Listed (UL/IEC 61010), CSA 22.2, CE, RCM, RoHS-compliant.

Note: Be sure to remove the front, back or side panels as required, and inspect the inside of the unit for shipping damage.

Key Features

The Trystar SER-32e Event Recorder is designed to be mounted on a standard DIN rail. The table below gives a description of each key feature.

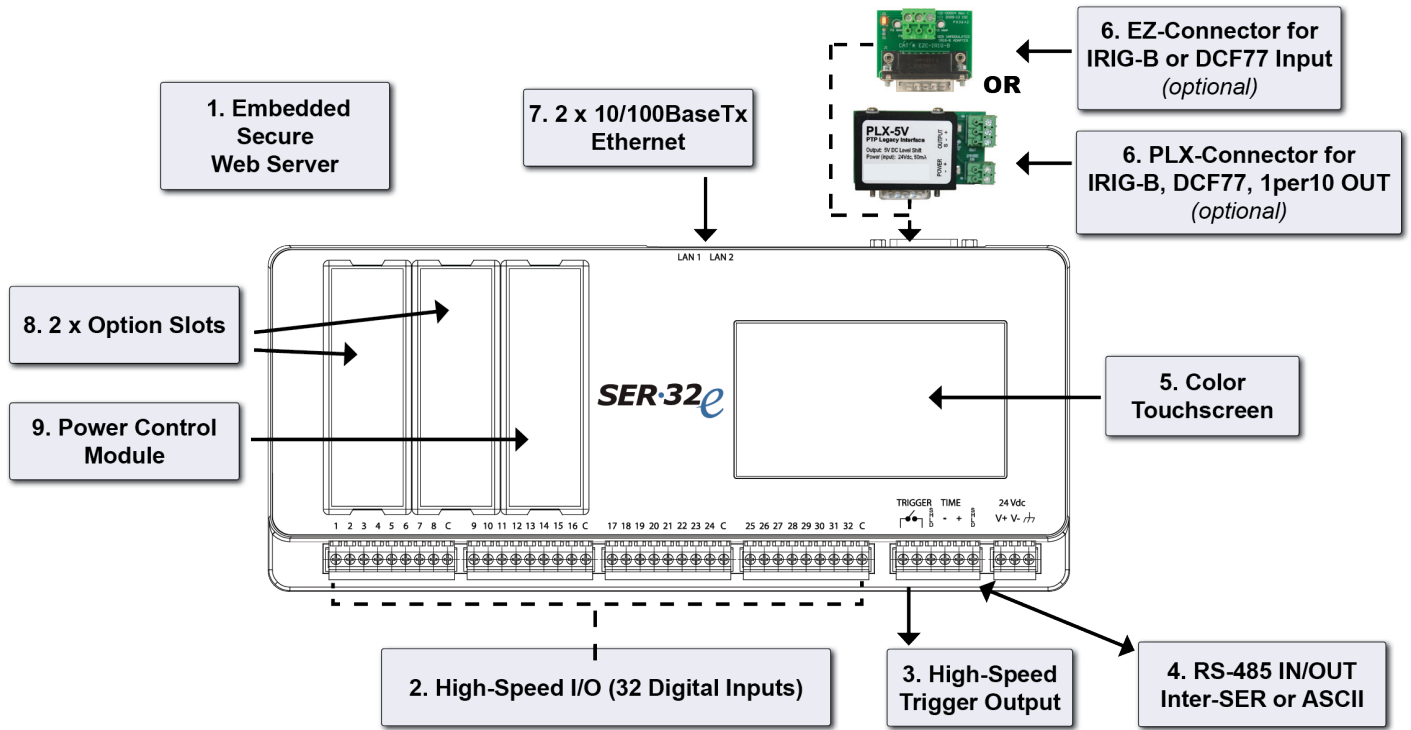

Figure 1-2. Trystar Event Recorder key features

Table 1-1—Key Features

Feature	Description
1. Embedded Secure Web Server	Set up the device, monitor status, counters, diagnostics, and view event log records. Use web browser for firmware updates, manage security certificates, and upload/download configuration files.
2. High-Speed I/O	32 digital inputs in four (4) groups of eight (8) inputs.
3. High-Speed Trigger Output	Digital output contact which can be configured to close momentarily on state change of one or more inputs to trigger an action, such as a waveform capture (WFC) by a compatible power meter.
4. Time Sync IN/OUT (RS-485)	Time sync OUT (when serving as a time-sync master to other devices) or time sync IN (when synchronized to another SER time-sync master) over RS-485 (2-wire plus shield). ASCII / RS-485 output is selectable.
5. Color Touchscreen	Color resistive touchscreen display (4.3" TFT, 480 x 272 pixels) for local access to status, events and setup parameters. User configurable brightness and screen saver.
6. EZC-IRIG-B/DCF77 (IN) or PLX-5V/PLX-24V (OUT)	DB-15-to-screw-terminal connector: EZ Connector (EZC) to accept IRIG-B or DCF77 time source (IN), or PLX (PLX-5V or PLX-24V) to output IRIG-B, DCF77 or 1per10 (OUT).

7. Ethernet Interface (10/100BaseTx)	Two Standard Ethernet RJ-45 network interface, with indicator LEDs for speed (10 or 100 Mbps) and link/activity. The SER auto-detects Ethernet wiring polarity and network speed.
8. Expansion Slots	Two expansion slots for future I/O expansion modules.
9. Power Control Module	Provides over 10 seconds of control power ride-through to ensure power system events are recorded. Includes replaceable battery for RTC (Real-Time Clock) backup.

Ordering Information

The following models and accessories are available for the Trystar SER-32e:

Table 1-2— Trystar SER and accessories catalog numbers

	Catalog no.	Description
Sequence of Events Recorder (SER)	SER-32e	Trystar Event Recorder, 32-input, PTP, secure web, 2x option slots, control power ride-thru
Accessories	EZC-IRIG-B	EZ connector for SER (input: IRIG-B time source)
	EZC-DCF77	EZ connector for SER (input: DCF77 time source)
	PLX-5V	PTP Legacy Interface (5V DCLS, for unmodulated IRIG-B output)
	PLX-24V	PTP Legacy Interface (24V DCLS, for DCF77, 1per10 or 24V IRIG-B output to STR-IDM)
	PLXe-5V	PTP Legacy Interface Self Powered (5V DCLS, for unmodulated IRIG-B output)

INSTALLATION

Dimensions

The dimensions for the Trystar SER-32e Event Recorder are illustrated below.

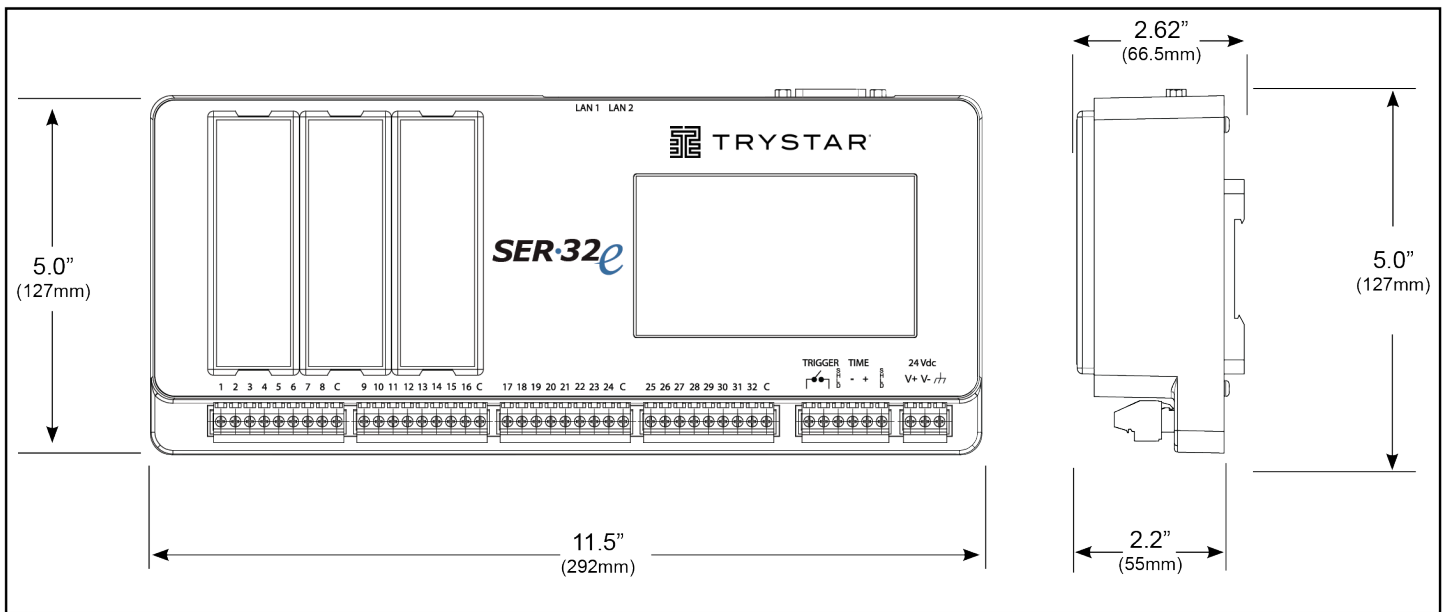

Figure 2-1. Front and side views, with dimensions—SER-32e

Mounting Considerations

The Trystar Event Recorder is designed to be mounted on a standard DIN rail in the orientation shown below. When choosing a mounting location, consider the following:

- Allow for easy access.
- Allow space for all wires to be neatly routed away from the device.
- Allow sufficient ventilation to stay within the operating temperature limits of the device (see section 7—Specifications).

Typical locations for mounting the SER include the following:

- Power equipment cell or compartment.
- Office or raised-floor environment.
- Auxiliary control panel or cabinet.

DIN-rail Mounting

The SER-32e is mounted to a standard (35mm) DIN rail by engaging the bottom edge first, then rotated into place as shown below:

1. Start by engaging the lower edge of both DIN-mounting brackets with the bottom of the DIN rail as shown.
2. Then raise the device to compress the spring-loaded jaws in the bottom clips to allow clearance for the edge of the top clips.
3. Rotate the top of the device to vertical...
4. ...and then lower the device into place onto the DIN rail.

To uninstall, simply reverse this process: raise the device (to compress the bottom springs) and then rotate the top outward.

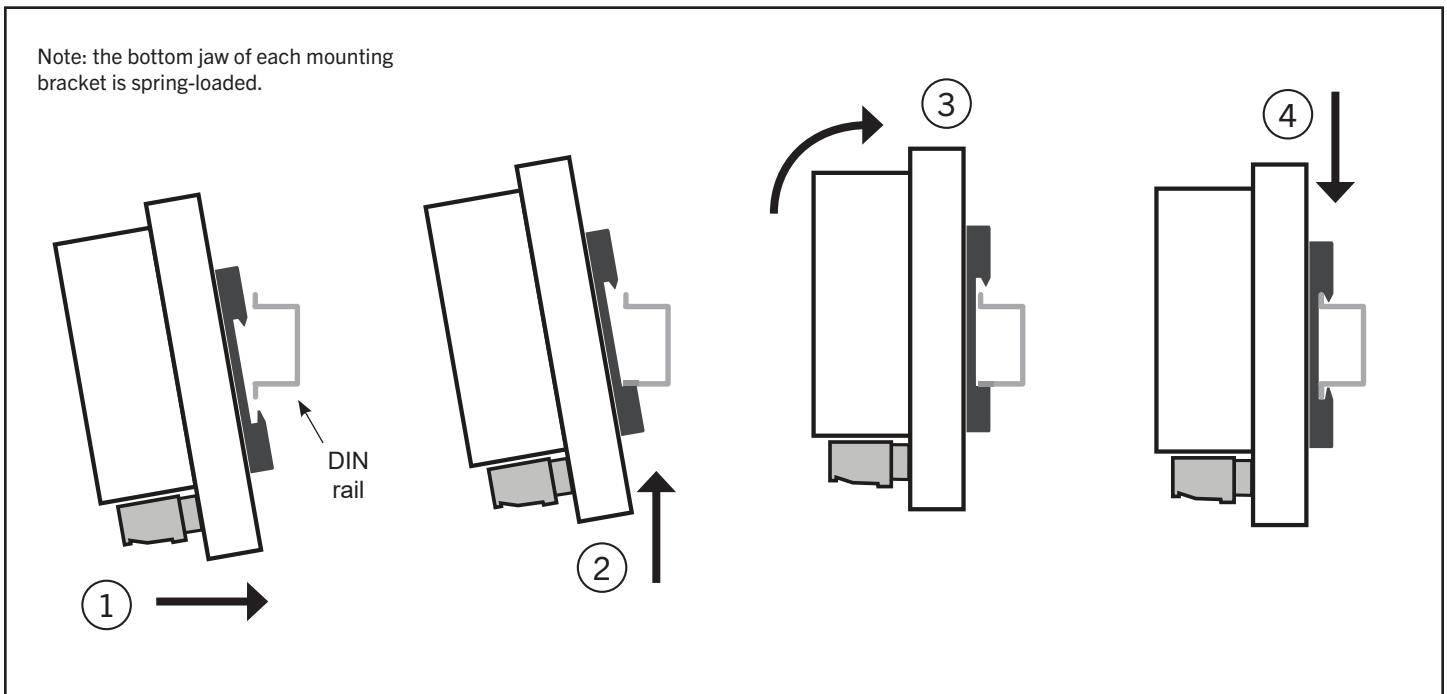

Figure 2-2. DIN-rail mounting (side views)

WIRING

Wiring Connections for SER-32e

Note: With PTP or IRIG-B time source, the Trystar SER typically requires 30 seconds to lock onto the precision time reference (Time Quality = Good). DCF77 may require up to 10 minutes.

An overview of wiring connections for the Trystar SER-32e is shown below. Wiring connections include two (2) Ethernet network interface RJ-45 connectors (*either Ethernet interface port can be used, but not at the same time*), time source input, digital inputs, control power input, optional trigger output, and optional time-sync IN or OUT (via RS-485 and/or PLX-5V or PLX-24V).

Removable plug-in, screw-terminal connectors are provided for connections at bottom. Optional adapters convert the DB-15 options connector to a screw-terminal connector to support input or output of legacy protocols, such as IRIG-B or DCF77.

32 digital inputs (numbered 1-32) are divided into four (4) groups of eight (8), each sharing a common return (marked "C").

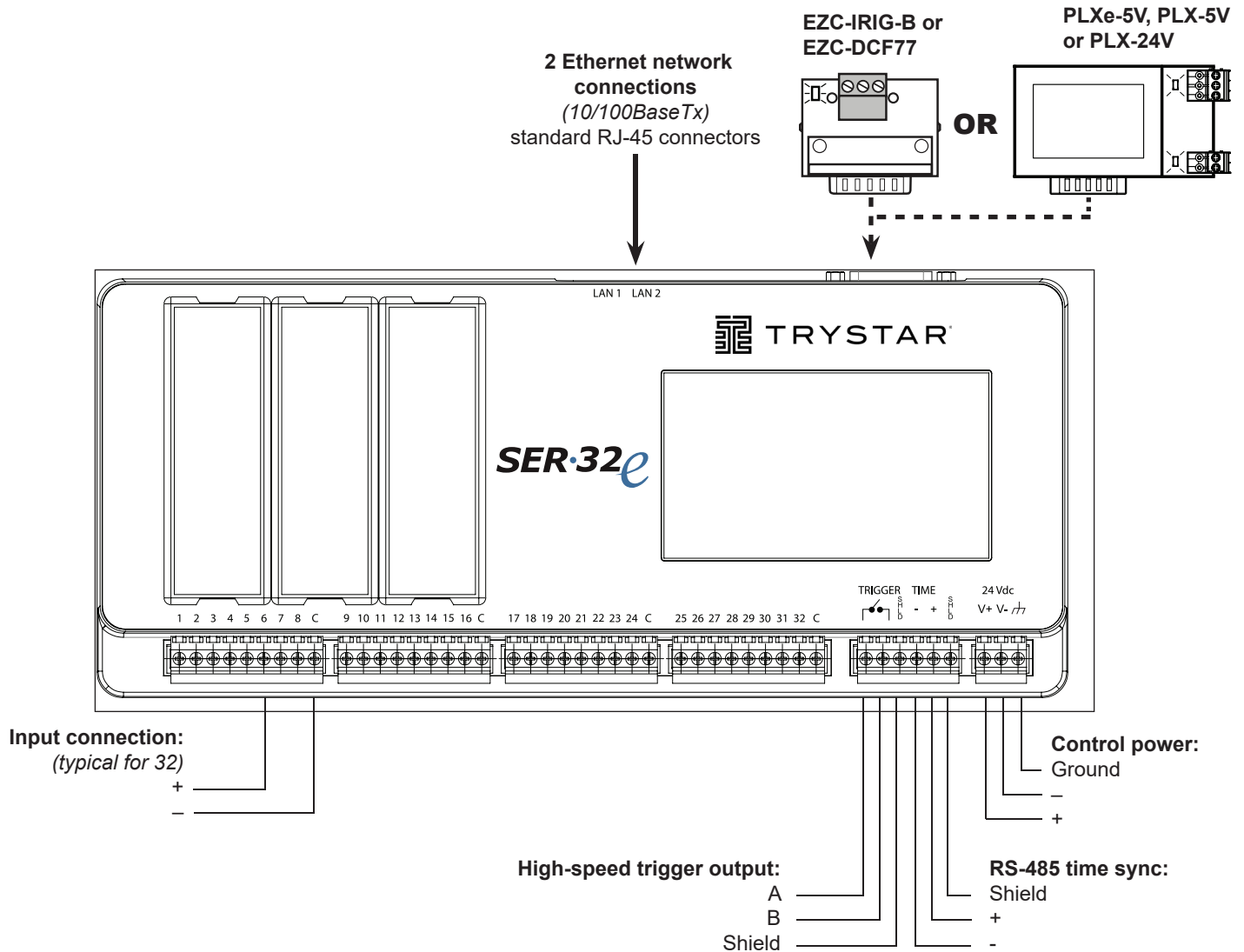

Figure 3-1. SER-32e wiring connections

Digital Inputs (SER-32e)

The SER-32e has 32 isolated digital inputs arranged in four (4) groups of eight (8), each sharing a common return, wired as shown.

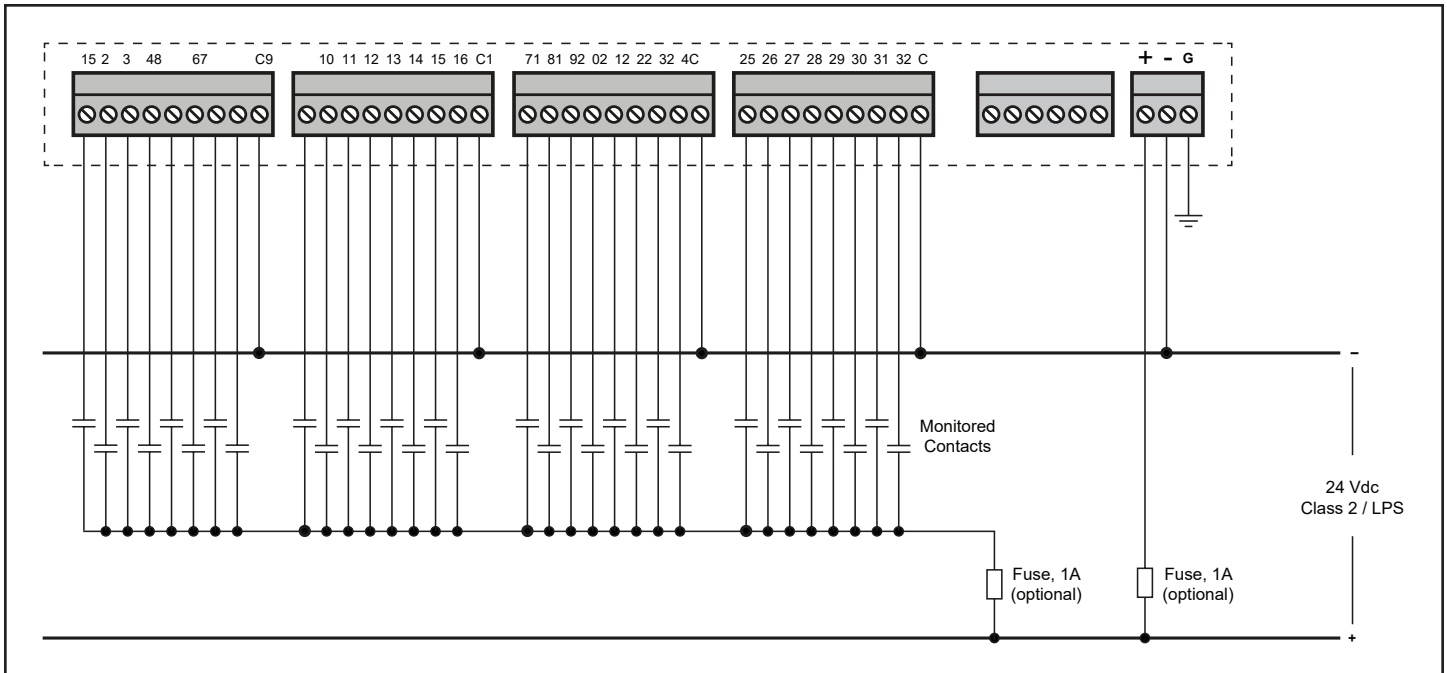

Figure 3-2. Digital input wiring connections (SER-32e)

Control Power

The Trystar SER-32e requires a control power source with nominal voltage of 24 Vdc. The control power connector has three terminals: 24 Vdc positive and common connections and a chassis ground connection (green-wire ground).

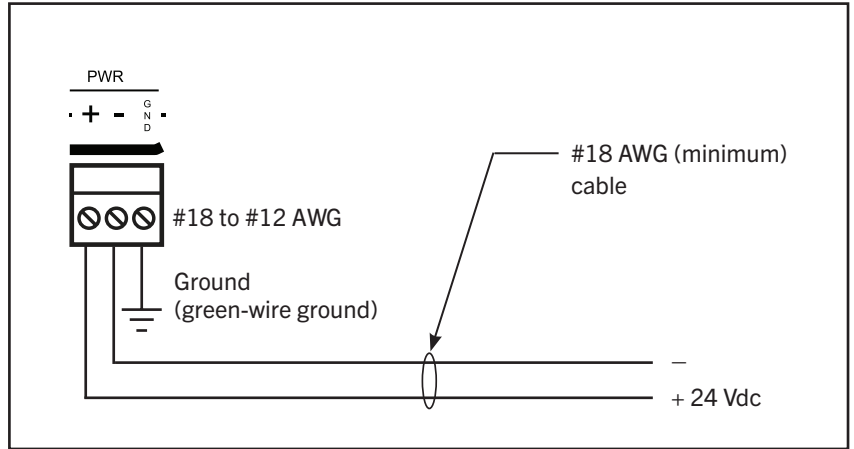

Figure 3-3. Control power connections

Time Sync (PTP Master or Slave)

The Trystar SER-32e Event Recorder supports PTP (per IEEE 1588). User setup determines whether the device functions as a PTP master or PTP slave (or neither). The SER-32e offers several time-sync input and time-sync output options, as well as trigger output for waveform capture. PTP can be used in conjunction with these capabilities to form a flexible system that is compatible with third-party clocks and can “PTP-enable” meters and relays that currently support only legacy protocols.

In the example shown in Figure 3-6, one or more Trystar Event Recorders are configured as PTP slaves and sync automatically with a GPS clock (by others) which serves as PTP master (grandmaster).

PTP time sync is accomplished over the same Ethernet network used for data communications using a standard Ethernet cable (e.g. Cat 5e).

Alternatively, a Trystar SER-32e can be the PTP master. In the example shown in Figure 3-7, the first Trystar Event Recorder serves as PTP grandmaster; all other SERs sync automatically using PTP over the Ethernet network. The SER serving as grand master may use any convenient time source: IRIG-B, DCF77, NTP or even periodic updates from an EPMS server using Modbus TCP or RESTful API over Ethernet.

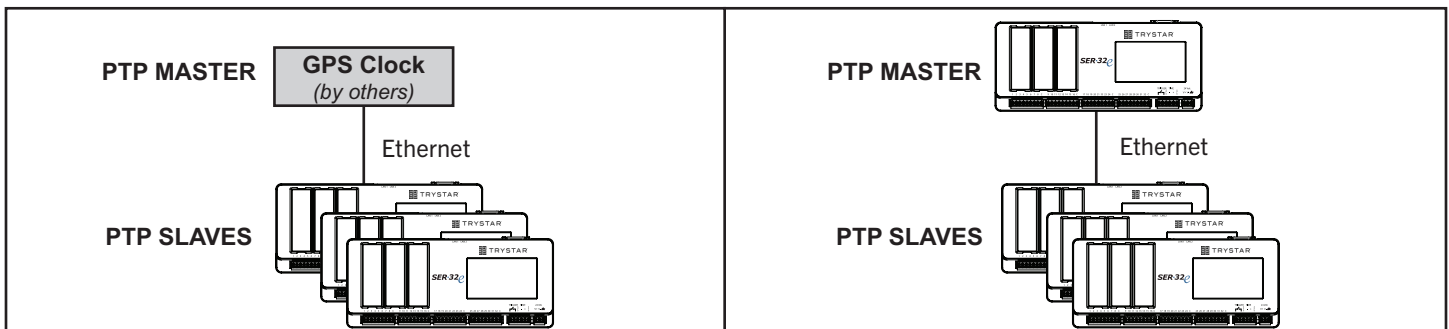

Time Sync IN (IRIG-B or DCF77)

The Trystar SER accepts IRIG-B or DCF77 time reference via its DB-15 options connector at the top of the device. An optional wiring accessory (EZC-IRIG-B or EZCDF77) facilitates wiring as shown in the figure below.

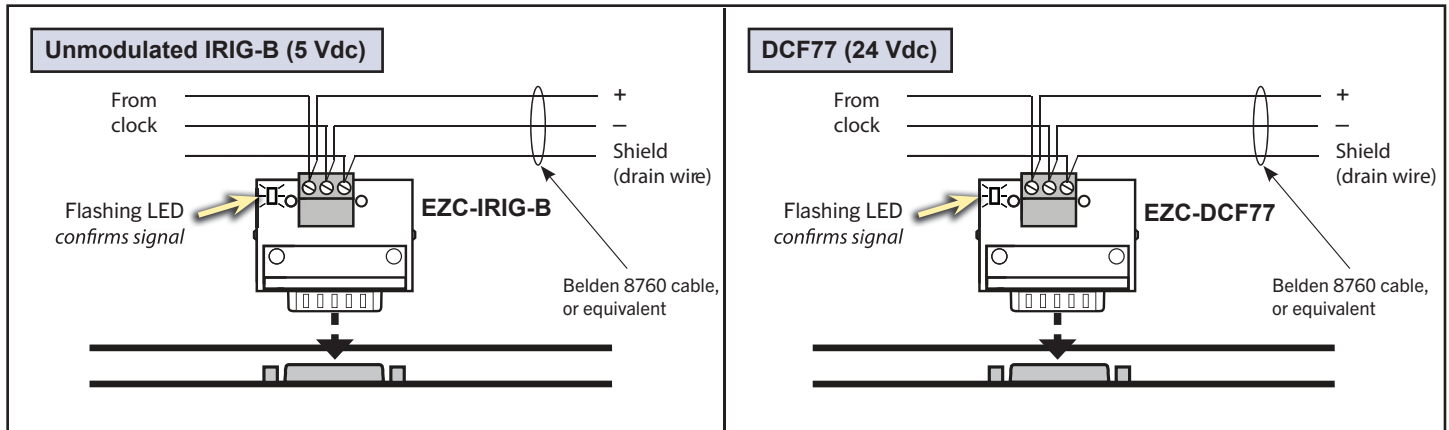

Figure 3-6. Trystar SER uses optional EZC-IRIG-B or EZC-DCF77 to accept time source of IRIG-B or DCF77, respectively

Time Sync OUT (IRIG-B, DCF77 or 1per10)

When the time source is PTP or NTP, the Trystar SER can be configured to output a legacy protocol (IRIG-B, DCF77 or 1per10) via its DB-15 connector using a PLX, type PLXe-5V, PLX-5V or PLX-24V, as shown below.

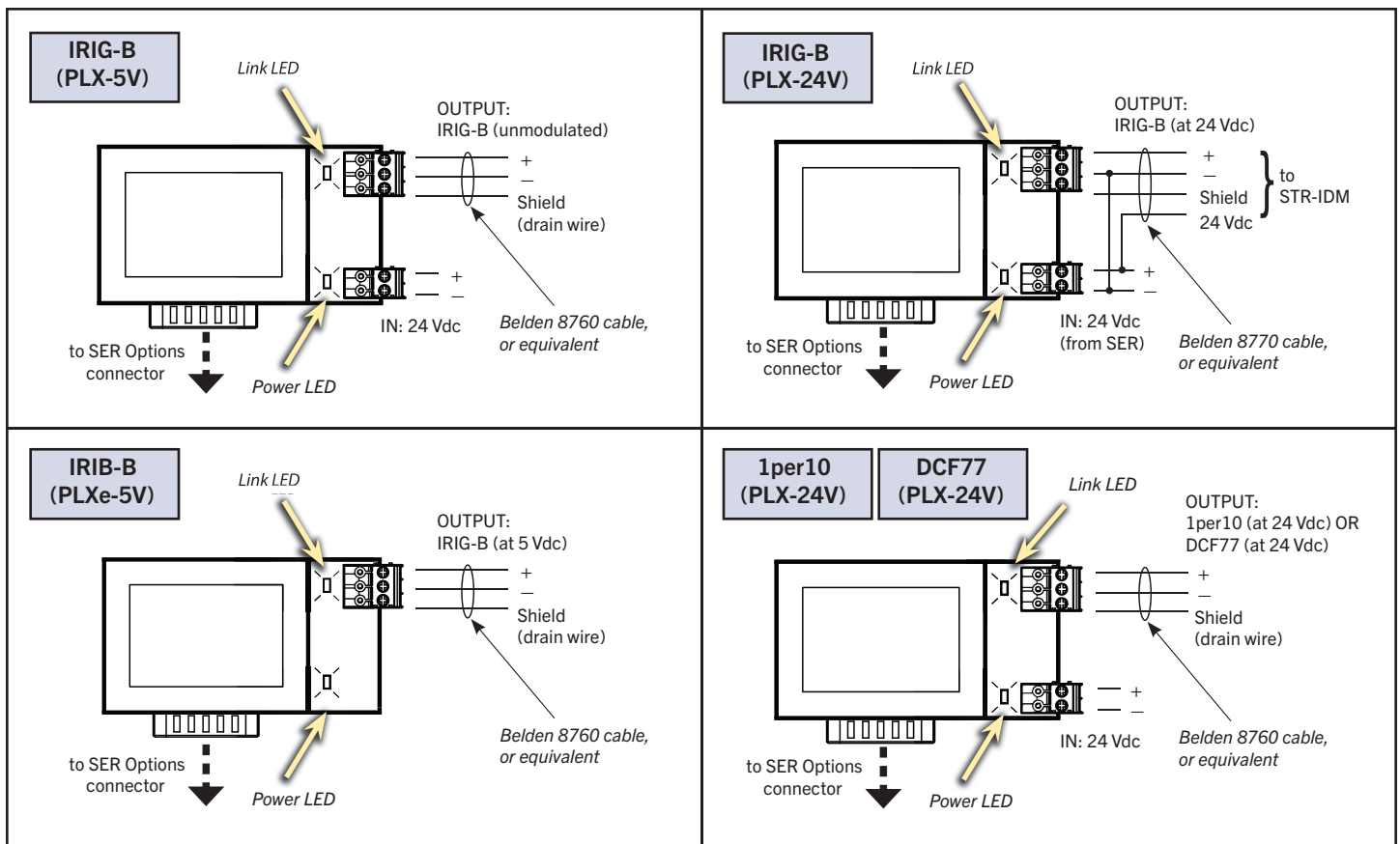

Figure 3-7. Trystar SER uses PLXe-5V, PLX-5V or PLX-24V to output legacy protocols (IRIG-B, DCF77 or 1per10) at 5V or 24V, respectively

RS-485 Time Sync IN/OUT (Inter-SER or ASCII OUT)

The Trystar SER inter-device time-sync (RS-485) can be wired to one device or daisy-chained to multiple devices. This is also used to output ASCII/RS-485: an ASCII string originally defined by Arbiter Systems called "ASCII + QUAL" (9600 bps). This consists of an on-time mark (OTM) once per second followed by ASCII representation of the date/time and time-quality as follows:

<soh>ddd:hh:mm:ssQ where: soh = Hex 01 (start bit = OTM) and Q = time quality (space = locked, ? = unknown)

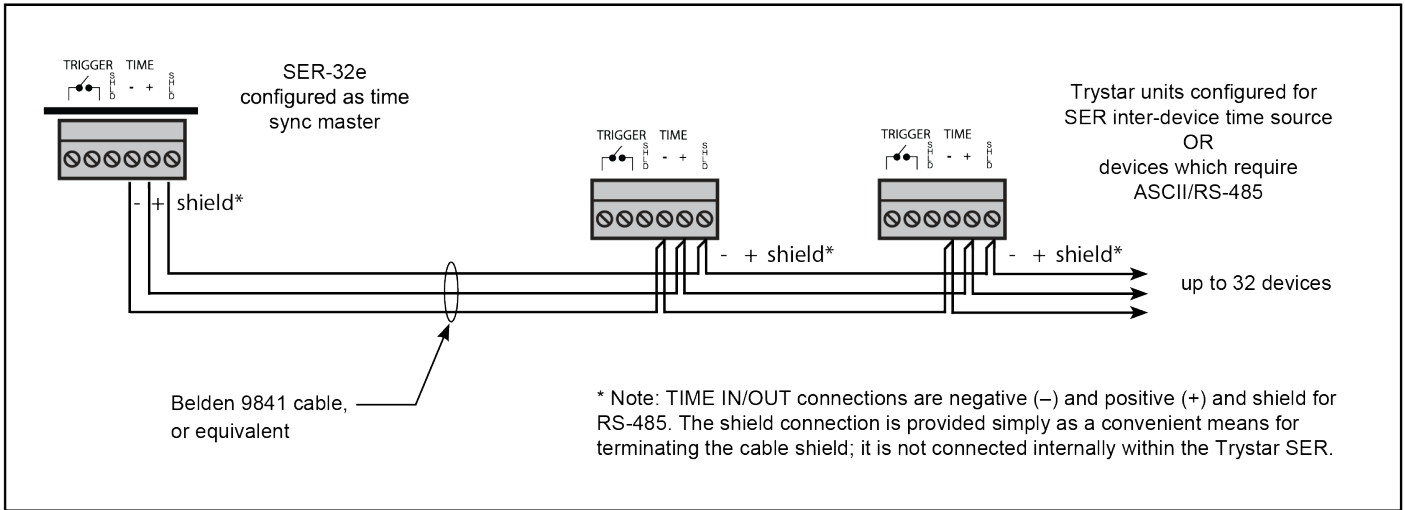

Figure 3-8 SER inter-device (RS-485) time sync input/output or ASCII/RS-485 time-sync output

Trigger Output (to One or More Devices)

The Trigger Output can be wired to a single device or in parallel to multiple devices as shown in the figure below. (Note: trigger output is available with all models.)

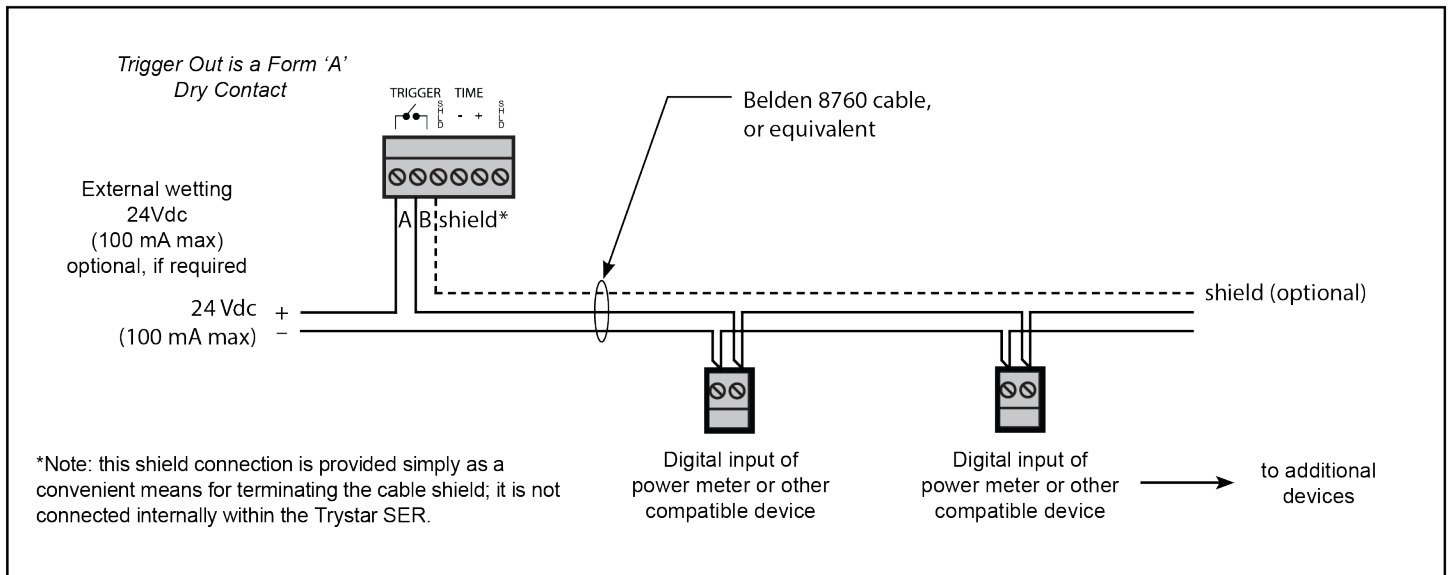

Figure 3-9. Trigger output connection to multiple devices

OPERATION

Local Display and Keypad

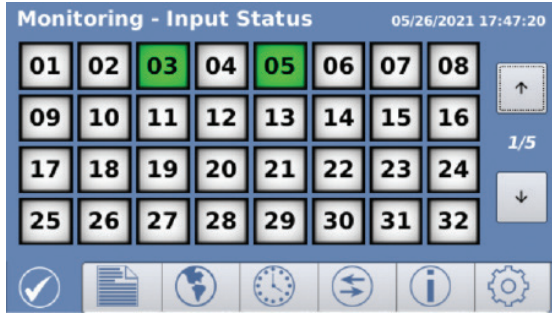

Figure 4-1. Color Touchscreen

The Trystar SER-32e features a 4.3” color TFT (480 x 272 pixels) touchscreen display to provide local access to status, events and setup parameters.

The SER screen displays viewing options to verify correct operation, including current date/time, time quality and time zone offset. In addition, communications parameters (DHCP, IP address, subnet mask, and default gateway) can be set or modified via “Setup-Communications”.

Menu structure and reference icons are shown below.

LEGEND	
	Monitoring
	Events
	Communications
	Time
	Input
	Diagnostic
	Setup

LCD Menu Structure

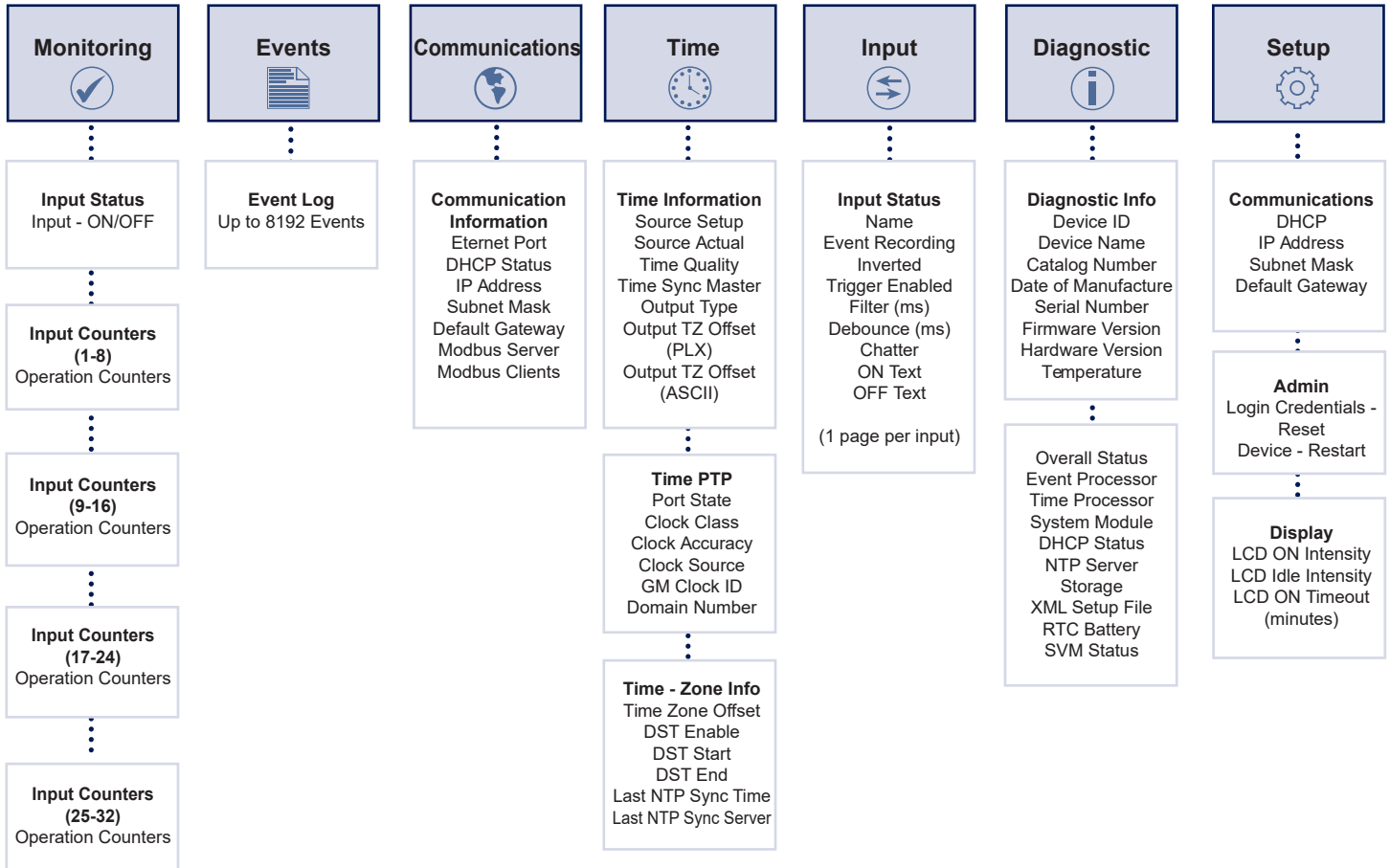

Figure 4-2. LCD display menu structure (model SER-32e example shown)

Initial Setup via Display



To change communications settings from the SER front panel, select the GEAR icon (⚙️) and press the EDIT button (page 1/3):

Use the ARROW keys (▼▲) to scroll to the desired screen.

For each screen:

- Press the ARROW keys (▼▲) to select the desired value or enter the desired value using the provided keypad.
- For each screen press EDIT / RESET / RESTART, modify values then press NEXT / APPLY.
- Touch any icon to exit setup for that screen.

The SER allows you to configure the touchscreen display for maximum viewing or to conserve energy. The SER's display has 8 intensity settings (0 - 7) and an ON timer to reduce the display intensity or turn the display OFF until touched. Default settings are ON intensity = 6, IDLE Intensity = 0, Timeout = 5 (minutes)

The SER provides administrative functions to reset login credentials (in case they are lost) and to restart the device.

To reset login credentials, press the GEAR icon to access the Setup - Administration menu.

- Press the down arrow to access Page 2/3.
- Press the 'Reset' button next to 'Login Credentials'.
- Press the 'Confirm' button to reset login credentials to factory default or 'Cancel' to return to the previous menu.

This action will reset the SER login credentials to factory defaults for 5-minutes. (user name = 'admin', password = 'csi_serial number'). Log into the SER using a web browse to set the desired user name and password. If the action is not completed within 5 minutes, the SER login credentials will be restored to the previous values.

To Restart the SER, press the GEAR icon to access the Setup - Administration menu.

- Press the down arrow to access Page 2/3.
- Press the 'Restart' button next to 'Device'.
- Press 'RESTART' button in 'Confirmation' screen to restart the SER.

Figure 4-3. Initial setup via LCD/keypad

Table 4-1— Initial communications settings

Option	Description	Available values	Default
DHCP enabled	When enabled, the SER automatically obtains an IP address from a DHCP server at startup.	enabled or disabled	disabled
IP address	The network (IP) address of the SER.	0.0.0.0 to 255.255.255.255	169.254.0.10
Subnet mask	The Ethernet IP subnet mask of your network.	0.0.0.0 to 255.255.255.255	255.255.0.0
Default gateway	The IP address of the gateway (router) serving the SER.	0.0.0.0 to 255.255.255.255	0.0.0.0

SETUP (WEB SERVER)

Initial Setup via Web Page (Direct-connect)

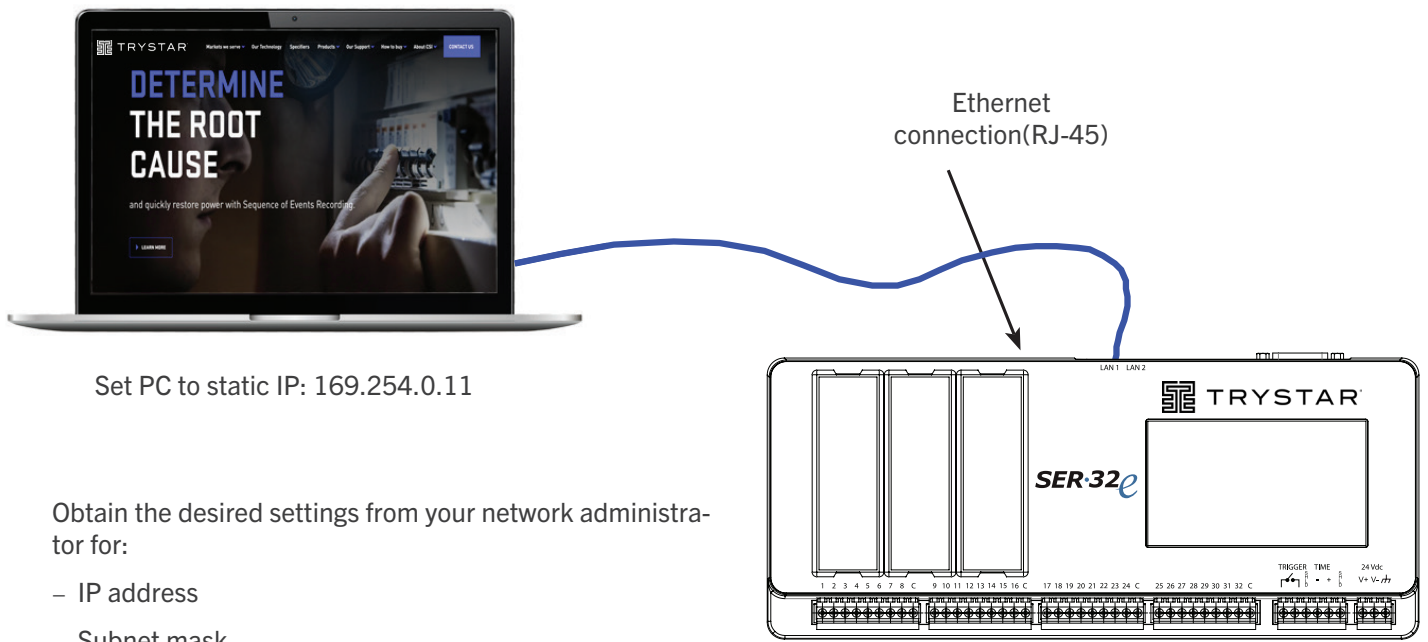

Set PC to static IP: 169.254.0.11

Obtain the desired settings from your network administrator for:

- IP address
- Subnet mask
- Default gateway

The SER has two (2) Ethernet ports (LAN1 / LAN2). Either port can be used, but only one can be connected at a time. If two ports are connected, only LAN 1 will be active.

Figure 5-1. Initial setup connection

Note: Initial setup of communications parameters can also be done via the front touchscreen. See previous page.

Direct connection to PC.

1. Connect the SER to your PC using a standard Ethernet patch cable. (The SER auto-detects wiring polarity— a special crossover cable is not required.)
2. Set PC to use static IP address of 169.254.0.11.
3. Apply power to the SER.
4. Open a standard web browser (Edge, Chrome and Firefox are recommended).
5. Type the default IP address 169.254.0.10 into your web browser.
6. Enter the default user name (admin) and password (csi_serial number) and click “Login” to access the home page.
7. Click the Setup tab, then change the network settings to those provided by your network administrator and click “Update” to save.
8. Disconnect the Ethernet patch cable and connect the SER to your local area network. Continue to the next section for additional setup.
9. Restore your PC to its previous network settings. (e.g., “Obtain IP address automatically.”)

Setup via Web Page (Over a Network)

Setup can be accomplished over an Ethernet network using a standard web browser.

At the login screen, enter user name (default = admin) and password (default = csi_device serial number).

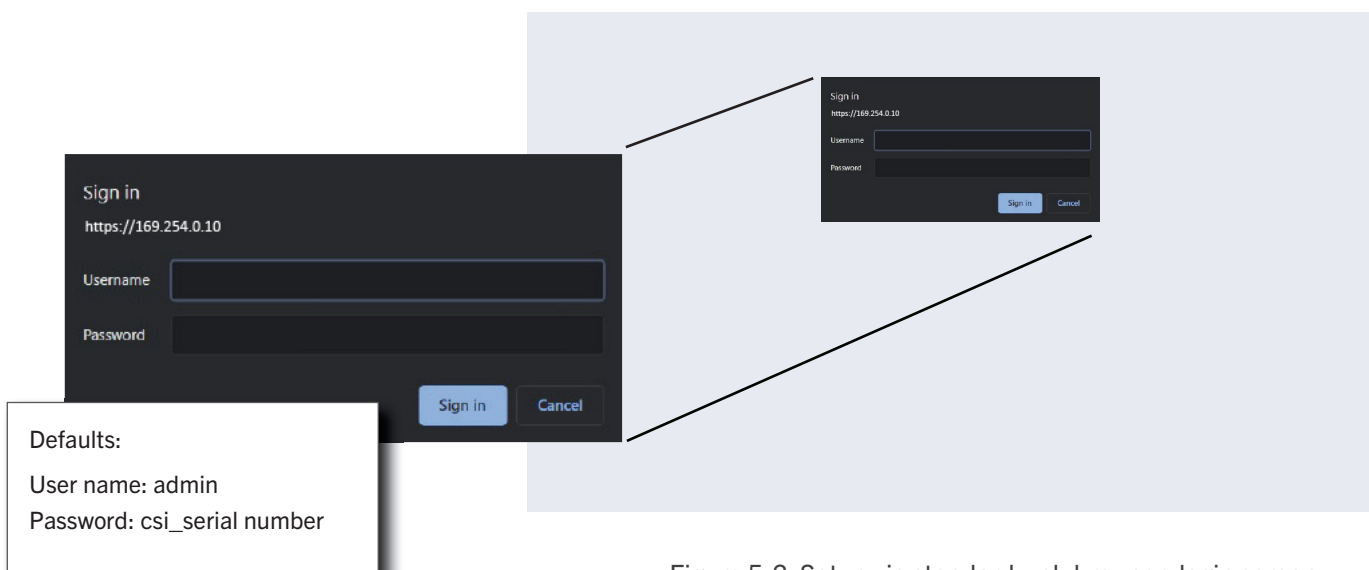

Figure 5-2. Setup via standard web browser: login screen

As shown below, the monitoring screen appears. Clicking the setup tab provides access to setup parameters.

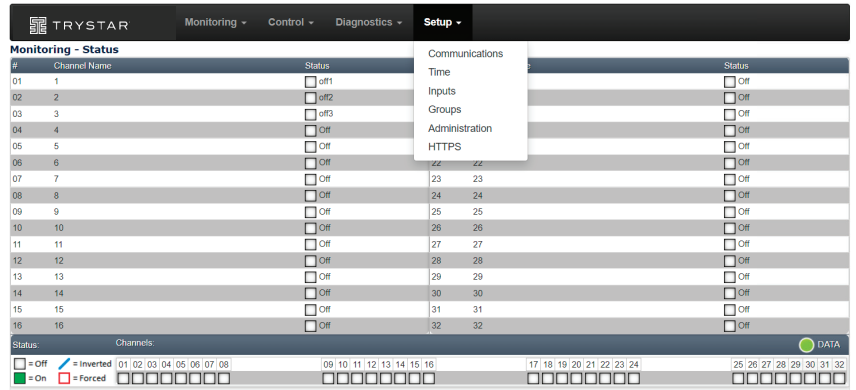

Figure 5-3. SER home web page (Monitoring screen)

Communications Setup

The SER features a standard Ethernet interface (10/100BaseTx) for connection to a local area network (LAN). The device auto-detects LAN used, wiring polarity and network speed (10 or 100 Mbps). To configure communication parameters, click “Communications” under the Setup tab to bring up the communications setup web page.

Note: The “Defaults” button loads default settings for the displayed page only, and changes are not saved until the user hits “Apply” and confirms. To set all setup values to default settings, visit all setup pages and click “Defaults” (followed by “Apply” to save changes.)

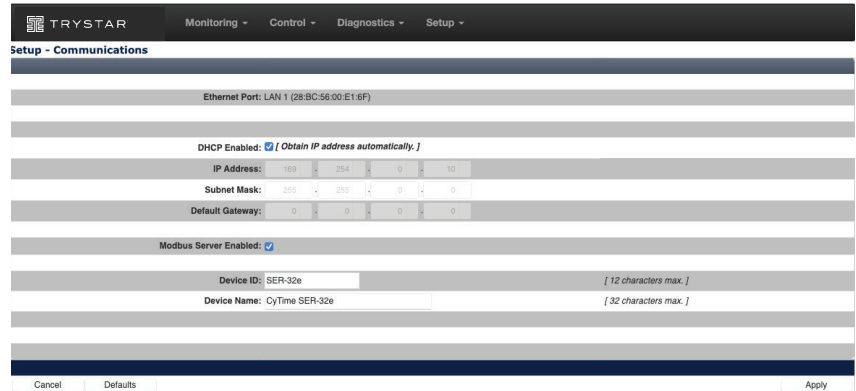

Figure 5-4. Communications setup web page

Table 5-1— Communications settings

Option	Description	Available values	Default
MAC Address	The physical address of the SER Ethernet port (unique value assigned at factory per port).	hh-hh-hh-hh-hh-hh (read-only)	assigned at factory
DHCP Enabled	When enabled, the SER automatically obtains an IP address from a DHCP server at startup.	enabled or disabled	disabled
IP Address	The network (IP) address of the SER.	0.0.0.0 to 255.255.255.255	169.254.0.10
Subnet Mask	The Ethernet IP subnet mask of your network.	0.0.0.0 to 255.255.255.255	255.255.0.0
Default Gateway	The IP address of the gateway (router) serving the SER.	0.0.0.0 to 255.255.255.255	0.0.0.0
Device ID	ID assigned to the SER (used by some PLCs and application software).	UTF-8 text string, ^① 12 characters max	Trystar SER
Device Name	Descriptive name assigned to the SER (used by SER web pages and some application software).	UTF-8 text string, ^① 32 characters max	Trystar Event Recorder
Disable Modbus TCP	When security is of utmost importance, the Modbus TCP interface can be disabled and data can be accessed using a RESTful API over secure connection (HTTPS).		Modbus TCP - ON

① Only the following special characters are available: ! @ # \$ % & * () _ - + = { } [] ; . ~ ` ' `

Time Setup

Clicking “Time” under the setup tab brings up the time setup web page:

Note: Only one protocol can be selected for output via the PLX connector (IRIG-B, DCF77 or 1per10).

Note: The accuracy of NTP time sync depends on external factors; therefore, when the SER time source is NTP, the SER uses only two states for Time Quality as follows: Time Quality = “2:OK (NTP)” if locked to a server, or “3: Bad (no sync)” if no NTP server is found.

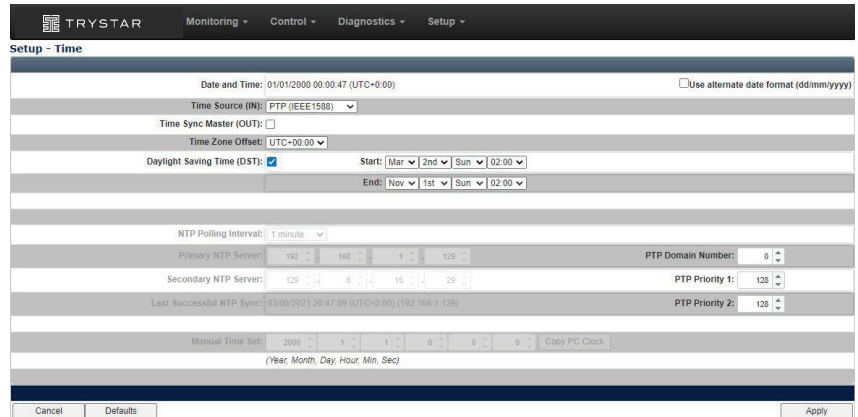

Figure 5-5. Time setup web page (with PTP time source setting shown)

Table 5-2— Time settings

Option	Description	Available values	Default
Time Source (IN)	Specifies the time source input: – IRIG-B (unmodulated, 5V DCLS) – DCF77 – SER inter-device (IRIG-B or DCF77 over RS-485) – PTP (per IEEE 1588) – NTP (network time server) – Manual time set (external time-sync)	IRIG-B, DCF77, Inter-SER (IRIG-B), Inter-SER (DCF77), PTP (IEEE 1588), NTP, or Manual (external)	PTP (IEEE 1588)
Time Sync Master (OUT)	Indicates if this SER also serves as the master time source for other devices. (Not applicable if time source is RS-485).	enabled or disabled	disabled
Time-sync Output	Specifies the output protocol (if time-sync master enabled): – PTP master (over Ethernet); – IRIG-B or DCF77 or 1per10 (via PLX adapter); – IRIG-B or DCF77 or ASCII (over RS-485)	PTP, IRIG-B, DCF77, 1per10, IRIG-B (RS-485), DCF77 (RS-485), or ASCII (RS-485)	none
Time Zone Offset	Offset in hours and minutes from Coordinated Universal Time (UTC) to adjust time for local time zone.	-12:00 to +13:00	0 (UTC+00:00)
Apply Offset to: PLX	Apply time zone offset to IRIG-B or DCF77 output via PLX	enabled or disabled	disabled
Apply Offset to: ASCII	Apply time zone offset to ASCII output (RS-485)	enabled or disabled	disabled
Alternate Date Format	The default date format for all display is mm/dd/yyyy When alternate date format is enabled, dd/mm/yyyy is used	enabled or disabled	disabled

Clicking “Time” under the setup tab brings up the time setup web page:

Note: The ASCII (RS-485) time-sync output option generates a proprietary code defined by Arbiter Systems called “ASCII + QUAL.” Typically, this is used to synchronize PowerLogic ION7550/7650 meters from Schneider Electric or 9510/9610 meters from Siemens. Set the meter’s time-sync protocol to “GPS:ARBITER” and COM port baud rate to 9600 bps.

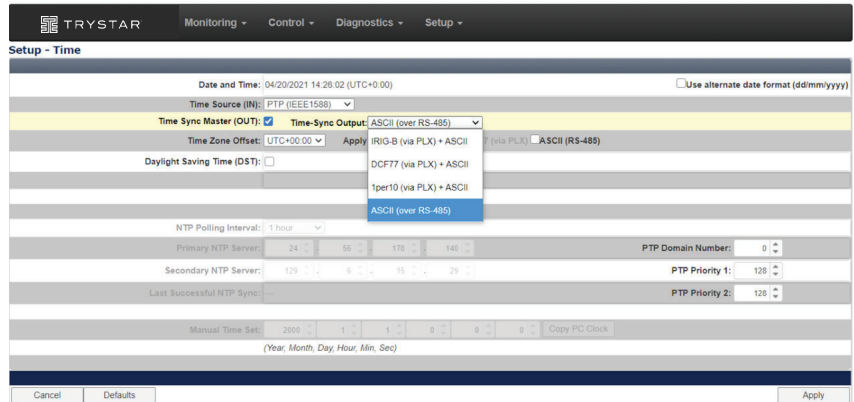

Figure 5-6. Time setup web page

Option	Description	Available values	Default
Daylight Saving Time (DST)	Apply DST adjustment (+1 hour) during specified period	enabled or disabled	disabled
DST Start and End ^②	Starting and Ending Date/Time to apply DST if enabled	Month: Jan - Dec Week: 1st - 5th (last) Day: Sun - Sat Time: 00:00 - 23:00	US defaults (shown above)
NTP Polling Interval	Interval used to update device clock from a network time server via NTP protocol	1, 2, 5, 10, 15, 30 min, 1, 2, 4, 8, 12 hours, 1 day, or 1 week	1 hour (60 minutes)
NTP Time Server IP (Primary and Secondary)	IP addresses of NTP time servers. (If sync via primary time server fails, device tries secondary time server IP address)	0.0.0.0 to 255.255.255.255	25.56.178.140 (www.nist.gov) 129.6.15.30 (time-c.nist.gov)
Last NTP Sync	Date/time of last successful NTP time sync, as well as the IP address of the NTP time server used	Jan 01, 2000 through Dec 31, 2120	(read-only)
PTP Domain Number	PTP slaves must use same domain number as PTP master	0 to 127	0
PTP Priority 1	For multiple PTP masters, best master clock algorithm uses this value as first “tie-breaker” to select grand-master	0 to 255	128
PTP Priority 2	For multiple PTP masters, best master clock algorithm uses this value as second “tie-breaker” to select grand-master	0 to 255	128
Manual Time Set	Allows the date/time to be set manually (external or copy from the PC clock’s current date and time)	Jan 01, 2000 through Dec 31, 2120	Jan 01, 2000 00:00:00

Inputs Setup

Clicking “Inputs” brings up the inputs setup web page:

The screenshot shows the 'Setup - Inputs' web page. It features a table with 16 rows, each representing an input configuration. The columns are: Enabled (checkbox), Input Name (text field), Filter (dropdown), Debounce (dropdown), Chatter (dropdown), Off Text (text field), On Text (text field), Trigger (checkbox), Inverted (checkbox), and Data Log Group (dropdown). All 16 inputs are enabled and have 'None' selected for the Data Log Group. The table is followed by a pagination bar showing '[1 to 16]' and '[17 to 32]', and buttons for 'Cancel', 'Defaults', and 'Apply'.

Enabled	Input Name	Filter	Debounce	Chatter	Off Text	On Text	Trigger	Inverted	Data Log Group
<input checked="" type="checkbox"/>	Input 01	20	20	0	Off	On	<input type="checkbox"/>	<input type="checkbox"/>	None
<input checked="" type="checkbox"/>	Input 02	20	20	0	Off	On	<input type="checkbox"/>	<input type="checkbox"/>	None
<input checked="" type="checkbox"/>	Input 03	20	20	0	Off	On	<input type="checkbox"/>	<input type="checkbox"/>	None
<input checked="" type="checkbox"/>	Input 04	20	20	0	Off	On	<input type="checkbox"/>	<input type="checkbox"/>	None
<input checked="" type="checkbox"/>	Input 05	20	20	0	Off	On	<input type="checkbox"/>	<input type="checkbox"/>	None
<input checked="" type="checkbox"/>	Input 06	20	20	0	Off	On	<input type="checkbox"/>	<input type="checkbox"/>	None
<input checked="" type="checkbox"/>	Input 07	20	20	0	Off	On	<input type="checkbox"/>	<input type="checkbox"/>	None
<input checked="" type="checkbox"/>	Input 08	20	20	0	Off	On	<input type="checkbox"/>	<input type="checkbox"/>	None
<input checked="" type="checkbox"/>	Input 09	20	20	0	Off	On	<input type="checkbox"/>	<input type="checkbox"/>	None
<input checked="" type="checkbox"/>	Input 10	20	20	0	Off	On	<input type="checkbox"/>	<input type="checkbox"/>	None
<input checked="" type="checkbox"/>	Input 11	20	20	0	Off	On	<input type="checkbox"/>	<input type="checkbox"/>	None
<input checked="" type="checkbox"/>	Input 12	20	20	0	Off	On	<input type="checkbox"/>	<input type="checkbox"/>	None
<input checked="" type="checkbox"/>	Input 13	20	20	0	Off	On	<input type="checkbox"/>	<input type="checkbox"/>	None
<input checked="" type="checkbox"/>	Input 14	20	20	0	Off	On	<input type="checkbox"/>	<input type="checkbox"/>	None
<input checked="" type="checkbox"/>	Input 15	20	20	0	Off	On	<input type="checkbox"/>	<input type="checkbox"/>	None
<input checked="" type="checkbox"/>	Input 16	20	20	0	Off	On	<input type="checkbox"/>	<input type="checkbox"/>	None

Figure 5-7. Inputs setup web page

Table 5-3— Inputs settings

Option	Description	Available values	Default
Input	Each input can be enabled for event recording. This does not affect status monitoring-only recording of state changes.	enabled or disabled	enabled
Input Name	Text string (UTF-8) to describe a given input.	32 characters max ①	Input nn
Filter	Filter time is the minimum time that an input must remain in its new state before it is recorded as an event. This helps eliminate false events due to noise, transients, etc.	0 to 65535 ms ①	20ms
Debounce	Debounce time is the period that event processing is suspended for a given input after an event has been recorded. This prevents recording multiple events for a single state change.	0 to 65535 ms ①	20ms
Chatter	Chatter count is the maximum number of events recorded for a given input per minute. If the number of events per minute exceeds the setpoint, the input will be disabled for further event processing until the number of events per minute drops below the setpoint. This prevents recording an excessive number of events due to a faulty input. Events are also generated to indicate the time event processing was suspended / resumed.	0 to 255 (0 = disabled)	0 (disabled)
Off Text and On Text	Customized label to describe an input's "off" state and "on" state	UTF-8, 16-char. ①	On / Off
High-speed Trigger Output	Any input can be configured to close the "Trigger Out" contact on status change. This is typically used to trigger a compatible power meter to capture current and voltage waveforms coincident with an event to aid analysis and troubleshooting.	enabled or disabled	disabled
Inverted	Any input can be designated as "inverted" and status reported opposite of its sensed state	normal or inverted	normal
Group Assignment (for Data Logs)	Each input can be assigned to a data log group for reporting purposes	None, or Group 01 to Group 16	None

1. Only the following special characters are available: ! @ # \$ % & * () _ - + = { } [] ; . ~ ` ' `
2. Setting this time too low (e.g., < 5 ms) can cause unwanted events to be recorded; setting too high (e.g., > 100 ms) can result in missed events.

Groups Setup

Clicking “Groups” brings up the Groups setup web page:

Note: To activate EPSS data logging, a group must be enabled, at least one group member defined (via Inputs Setup page) and sufficient space (records) allocated.

Note: Click the “Auto-Allocate” check box to have the system calculate the optimal number of records (equal allocation across all enabled groups). To return to previously saved values, click “Cancel.”

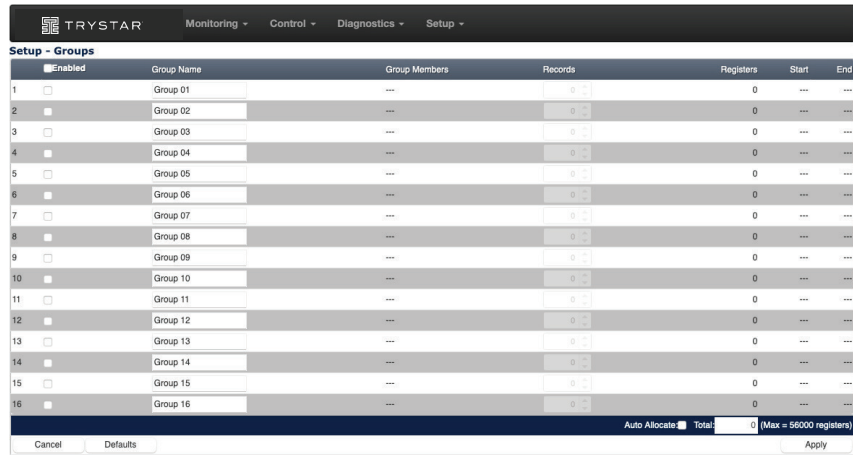

Figure 5-8. Group setup web page

Group assignments are used to establish an association among two or more inputs. For example, three inputs may be assigned to the group representing the normal, emergency and test states of an ATS. Enabling groups, assigning members, and allocating records causes the SER to log the status of all group members in a contiguous memory block accessible using Modbus TCP or RESTful API. This is used by some report modules, such as EPSS test reports, to confirm regulatory compliance. If logging has begun and a group is disabled, data logging for this group is suspended. However, changes to any group’s members or allocated records causes all data logs to be cleared and restarted.

Table 5-5— Groups settings

Option	Description	Available values	Default
Group	Each group can be enabled for data logging in the expanded Modbus register area. This does not affect status monitoring—only recording of state changes in the expanded memory area.	enabled or disabled	disabled
Group Name	Text string (UTF-8) to describe a given data log group.	32 characters max ^①	Group nn
Group Members	Inputs assigned to this group (from previous setup pages)	Inputs 01 to 32	----
No. of Records (Log File Depth)	Number of records to be allocated to each group’s data log, (up to 56000 registers maximum for all records).	0 to 16000	0
No. of Registers	This is calculated as the product of “1 + number of records” times the record length (4 + the number of group members)	0 to 56000 (read-only)	----
Starting Register	Starting register designated for a given group’s data log, based on the number of registers allocated.	409501 to 465500 (read-only)	----
Ending Register	Ending register designated for a given group’s data log, based on the number of registers allocated.	409501 to 465500 (read-only)	----

1. Only the following special characters are available: ! @ # \$ % & * () _ - + = { } [] ; . ~ ` `

Administration Setup

Clicking “Administration” brings up the administration setup web page:

Note: It is recommended the user change the user name and password upon setup of the SER-32e for security purposes.

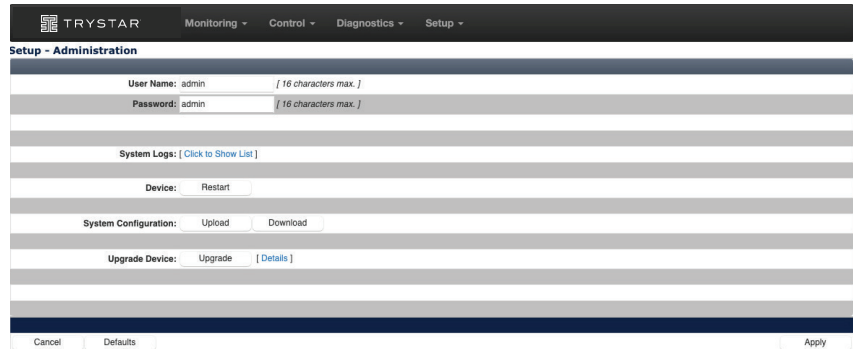

Figure 5-9. Administration setup web page

Table 5-6— Administration settings

Option	Description	Available values	Default
User Name	User name used to log in to the Trystar SER.	UTF-8 text string, ① 16 characters max	admin
Password	Password used to log in to the Trystar SER.	UTF-8 text string, ① 16 characters max	csi_Serial Number ②
Restart	Restarts unit. (Note: event recording is suspended momentarily while the device restarts)		
System Configuration			
Upgrade Device			

1. Only the following special characters are available: ! @ # \$ % & * () _ - + = { } [] ; . ~ ` ' `
2. Product passwords are unique to each device and include product serial numbers. Example: SER with serial number '12345' would have a password of: csi_12345. Product serial numbers are located on product and packaging labels, and can be found on the SER's diagnostic menu.

Alternate Setup: Editing XML File

Note: the XML setup file should only be modified by advanced users who are familiar with XML syntax, since errors may cause the unit to malfunction. Please refer to the Trystar SER Reference Guide (IB-SER-05) for additional details.

Alternate Setup: Editing XML File

Setup data is stored in non-volatile memory in an XML file format. Setup changes can therefore be made simply by editing this file using a text editor, such as Windows® Notepad. Standard setup templates can be created and replicated quickly across multiple units.

The setup file can be accessed over a network via the device's web interface through the Administration tab.

To preserve a backup copy of the setup file, go to the Setup / Administration page, download the “_SETUP.XML” to a local directory on a PC. To restore these settings, simply upload the file back to the device (overwrites existing _SETUP.XML file).

HTTPS

Clicking “HTTPS” brings up the HTTPS setup web page:



Figure 5-10. HTTPS setup web page

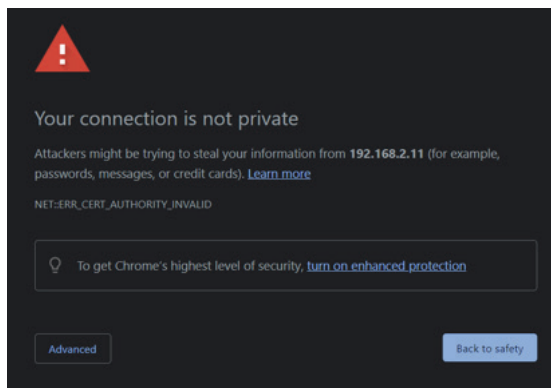

Figure 5-11. HTTPS certificate unrecognized

The SER-32e uses HTTPS to enhance security for all web (port 443) communications. HTTPS (HyperText Transport Protocol Secure) uses TLS (Transport Layer Security) encryption to secure communications and protect data exchanges between a web browser and the SER’s web server. The SER ships with a self-signed SSL (Secure Socket Layer) certificate installed. This self-signed certificate will not be recognized as a trusted web server and the web browser will prompt you with a security warning. (Figure 5-11)

To continue to the SER’s web interface, click “Advanced” and “Proceed to IP_Address (unsafe)”. The SER provides administration tools for security certificates by supporting the ability to generate new self-signed certificates, upload a custom certificate and delete a custom certificate (SETUP > HTTPS). A trusted custom certificate, provided by your IT department, can be installed on the SER resulting in it being a trusted web server.

Table 5-7— HTTPS Settings

Option	Description	Default
SSL Certificate Details		
Begin Date:	Date certificate was created	
End Date:	Expiration date for certificate	Expiration is 2 years for self-signed certificate
Subject:	Certificate name	C=US CN=SER32e-00E023 O=Trystar
Generate new self-signed certificate:	Control to generate a new self-signed certificate	
Upload custom certificate:	Control to upload a custom certificate	
Delete custom certificate:	Control to delete the certificate	

MONITORING (WEB SERVER)

Monitoring: Status

The Trystar SER-32e Event Recorder monitors the status of 32 high-speed input channels. Data is available via the Ethernet communications interface using Modbus TCP protocol, RESTful API or its embedded web server using a standard web browser.

To view status using a standard web browser, open the browser and type the IP address of the SER and press Enter. The unit’s home page is the “Monitoring” web page called “Status.” Sample channel status details are shown:

All of these fields can be customized:

- Channel name (“Main CB”)
- OFF/ON text (“OPEN”/“CLOSED”)

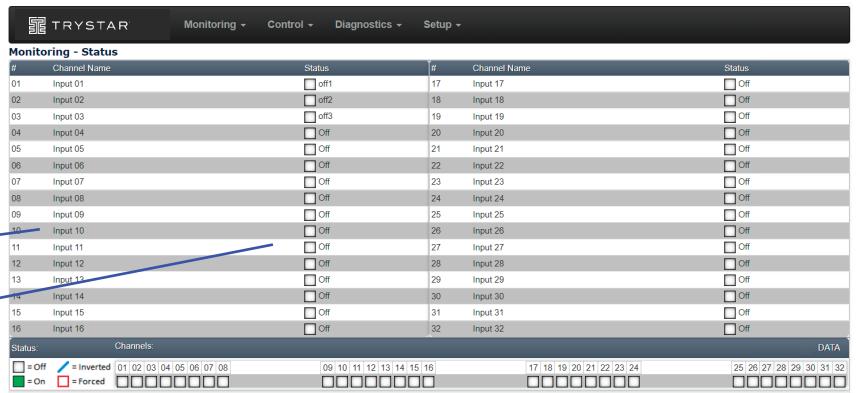

Figure 6-1. Monitoring: status web page

Note: The “Forced OFF” and “Forced ON” TEST functions refer to an override of the external monitored signals connected to each channel, and “forcing” these OFF or ON for reporting or logging by the SER. This simulation allows testing of host software without the need to physically open/close the connected equipment.

The Status page provides real-time status of all 32 channels, refreshed about once per second. The green “DATA” light flashes with each set of new data to confirm ongoing connection with the SER. Default values for channel names and OFF/ON states are shown in the example above. In an actual application, user-configured labels can greatly enhance the readability of the information. For example, Input 01 could be labeled “Main breaker” and OFF/ON states labeled “Open/Closed.”

In addition to normal status reporting, the following are supported:

Inverted. Any input can be configured with inversion “enabled.” This inverts the state of a monitored input for reporting or logging purposes. For example, a normally-closed contact can be set to “inverted” and its status reported OFF when in normal mode.

Forced OFF or ON. The SER supports a simulation TEST mode (via the Control web page or via Modbus command register), and all channels are initialized to OFF. Auto-test mode simulates closing all external contacts sequentially (“Forced ON”) and then back off again (“Forced OFF”). Manual-test mode starts with all channels Forced OFF, and the user can simulate the closing of each channel individually or in groups (“Forced ON”). If an input is also set to inverted, then its reported state will be opposite to the forced (simulated) condition.

Data Page (Counters)

The Data page displays operations counters and the last reset date and time. If a channel is enabled for event recording, each status change (transition from Off -to-On or On-to-Off) increments its counter value.

Clicking “Data” under the monitoring tab brings up the following web page:

Note: Counters are subject to filter, debounce and chatter functions used for event recording. Therefore, counter values only increment when a corresponding status-change event is recorded for a given channel (input).

#	Channel Name	Counter	Last Reset	#	Channel Name	Counter	Last Reset
01	Input 01	0	01/01/1970 00:00:00	17	Input 17	0	01/01/1970 00:00:00
02	Input 02	0	01/01/1970 00:00:00	18	Input 18	0	01/01/1970 00:00:00
03	Input 03	0	01/01/1970 00:00:00	19	Input 19	0	01/01/1970 00:00:00
04	Input 04	0	01/01/1970 00:00:00	20	Input 20	0	01/01/1970 00:00:00
05	Input 05	0	01/01/1970 00:00:00	21	Input 21	0	01/01/1970 00:00:00
06	Input 06	0	01/01/1970 00:00:00	22	Input 22	0	01/01/1970 00:00:00
07	Input 07	0	01/01/1970 00:00:00	23	Input 23	0	01/01/1970 00:00:00
08	Input 08	0	01/01/1970 00:00:00	24	Input 24	0	01/01/1970 00:00:00
09	Input 09	0	01/01/1970 00:00:00	25	Input 25	0	01/01/1970 00:00:00
10	Input 10	0	01/01/1970 00:00:00	26	Input 26	0	01/01/1970 00:00:00
11	Input 11	0	01/01/1970 00:00:00	27	Input 27	0	01/01/1970 00:00:00
12	Input 12	0	01/01/1970 00:00:00	28	Input 28	0	01/01/1970 00:00:00
13	Input 13	0	01/01/1970 00:00:00	29	Input 29	0	01/01/1970 00:00:00
14	Input 14	0	01/01/1970 00:00:00	30	Input 30	0	01/01/1970 00:00:00
15	Input 15	0	01/01/1970 00:00:00	31	Input 31	0	01/01/1970 00:00:00
16	Input 16	0	01/01/1970 00:00:00	32	Input 32	0	01/01/1970 00:00:00

Figure 6-2. Data web page

Resets Page

The Resets page allows reset of operations counters, either individually or all at once. From the Control tab, clicking “Resets” brings up the following web page:

#	Channel Name	Reset	Last Reset	#	Channel Name	Reset	Last Reset
01	Input 01	<input type="checkbox"/>	01/01/1970 00:00:00	17	Input 17	<input type="checkbox"/>	01/01/1970 00:00:00
02	Input 02	<input type="checkbox"/>	01/01/1970 00:00:00	18	Input 18	<input type="checkbox"/>	01/01/1970 00:00:00
03	Input 03	<input type="checkbox"/>	01/01/1970 00:00:00	19	Input 19	<input type="checkbox"/>	01/01/1970 00:00:00
04	Input 04	<input type="checkbox"/>	01/01/1970 00:00:00	20	Input 20	<input type="checkbox"/>	01/01/1970 00:00:00
05	Input 05	<input type="checkbox"/>	01/01/1970 00:00:00	21	Input 21	<input type="checkbox"/>	01/01/1970 00:00:00
06	Input 06	<input type="checkbox"/>	01/01/1970 00:00:00	22	Input 22	<input type="checkbox"/>	01/01/1970 00:00:00
07	Input 07	<input type="checkbox"/>	01/01/1970 00:00:00	23	Input 23	<input type="checkbox"/>	01/01/1970 00:00:00
08	Input 08	<input type="checkbox"/>	01/01/1970 00:00:00	24	Input 24	<input type="checkbox"/>	01/01/1970 00:00:00
09	Input 09	<input type="checkbox"/>	01/01/1970 00:00:00	25	Input 25	<input type="checkbox"/>	01/01/1970 00:00:00
10	Input 10	<input type="checkbox"/>	01/01/1970 00:00:00	26	Input 26	<input type="checkbox"/>	01/01/1970 00:00:00
11	Input 11	<input type="checkbox"/>	01/01/1970 00:00:00	27	Input 27	<input type="checkbox"/>	01/01/1970 00:00:00
12	Input 12	<input type="checkbox"/>	01/01/1970 00:00:00	28	Input 28	<input type="checkbox"/>	01/01/1970 00:00:00
13	Input 13	<input type="checkbox"/>	01/01/1970 00:00:00	29	Input 29	<input type="checkbox"/>	01/01/1970 00:00:00
14	Input 14	<input type="checkbox"/>	01/01/1970 00:00:00	30	Input 30	<input type="checkbox"/>	01/01/1970 00:00:00
15	Input 15	<input type="checkbox"/>	01/01/1970 00:00:00	31	Input 31	<input type="checkbox"/>	01/01/1970 00:00:00
16	Input 16	<input type="checkbox"/>	01/01/1970 00:00:00	32	Input 32	<input type="checkbox"/>	01/01/1970 00:00:00

Figure 6-3. Resets web page

A Counter Reset event will be recorded in the Event Log with date and time.

Events Page

The SER records the date and time of all events, such as the change of state of an input channel. Event data is accessible via Modbus TCP, RESTful API, local display (or touchscreen display) or may be viewed by clicking the link for the “Events” web page:

The screenshot shows the 'Monitoring - Events' web page. At the top, there is a navigation bar with 'Monitoring - Events' and sub-menus for 'Monitoring', 'Control', 'Diagnostics', and 'Setup'. Below this is a table of events with columns: Event, Date and Time, Channel, Event Type, Status, and Time Quality. The table shows a list of events from 8172 to 8192. A blue callout box highlights the event 8192 row. Below the table, there are control elements: 'Displaying Events: 8093 to 8192', a 'Load All Events' checkbox, an 'Export' button, 'Total Events: 8192', a 'Hide Seq #' checkbox, and an 'Auto' checkbox. A blue callout box highlights the 'Displaying Events' and 'Load All Events' area, and another highlights the 'Total Events' and 'Auto' area.

Event	Date and Time	Channel	Event Type	Status	Time Quality
8192	05/12/2021 19:27:24.358	Input 03	Input Status Change	Off -> On	0:Good (< 1ms)
8191	05/12/2021 19:27:24.233	Input 01	Input Status Change	Off -> On	0:Good (< 1ms)
8190	05/12/2021 19:27:24.107	Input 01	Input Status Change	Off -> On	0:Good (< 1ms)
8189	05/12/2021 19:27:23.982	Input 03	Input Status Change	On -> Off	0:Good (< 1ms)
8188	05/12/2021 19:27:23.856	Input 03	Input Status Change	On -> Off	0:Good (< 1ms)
8187	05/12/2021 19:27:23.731	Input 01	Input Status Change	On -> Off	0:Good (< 1ms)
8186	05/12/2021 19:27:23.605	Input 02	Input Status Change	On -> Off	0:Good (< 1ms)
8185	05/12/2021 19:27:23.480	Input 04	Input Status Change	Off -> On	0:Good (< 1ms)
8184	05/12/2021 19:27:23.354	Input 03	Input Status Change	Off -> On	0:Good (< 1ms)
8183	05/12/2021 19:27:23.229	Input 01	Input Status Change	Off -> On	0:Good (< 1ms)

Figure 6-4. Monitoring: events web page

The SER stores up to 8192 events, after which only the latest 8192 events are stored. Each event record contains:

- date and time of the event (adjusted for local time, if applicable)
- channel (input name)
- event type
- channel status
- time quality at time of the event
- sequence number (unique serial number, column hidden by default)

When the page is first accessed, the last 100 events are loaded and the 20 most recent are displayed, starting with the most recent event at the top.

Click any column heading to sort events. Click the “Load all events” check box to display all stored events.

By default, the page checks for new events in the background and automatically adds them to the display. To prevent automatic update, deselect the “Auto” check box. The page will still check for new events but they will not be shown until “Auto” is checked again. Any recent events added can be identified in the “Events” and “Date and Time” columns.

Finally an Export button allows the user to export (save) all displayed event data to a CSV file for further analysis in Microsoft Excel® or other software. Please see Trystar Tech Note TN-201 for more details on exporting SER data to CSV, as well as how to format the date/time cells in Excel for proper display with millisecond resolution.

Control: Test

Note: While operating in test mode, the SER suspends normal event recording. In addition, counters are not affected by test events.

The test function simulates status changes to facilitate testing of application software. Each status change is reflected in Modbus TCP status registers and recorded as a test event in the event log. Test events are also recorded to mark the start and end of test mode.

Clicking the “Control” tab brings up the following web page:

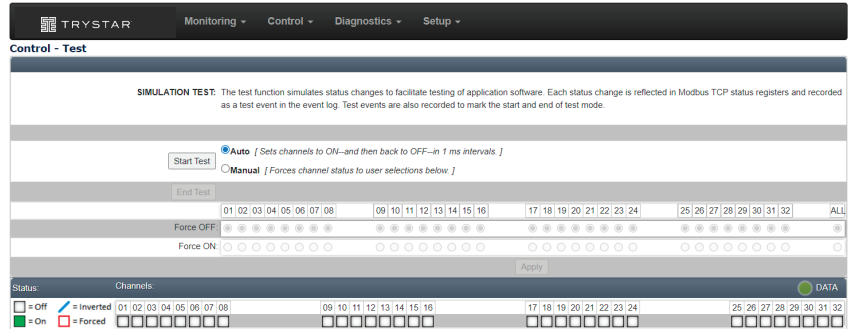

Figure 6-5. Control: Simulation test page (Manual mode shown)

Choose one of two test modes, then click the “Start Test” button to begin:

- **Auto**— Sets channels to ON and then back to OFF, automatically.
- **Manual**— Forces channel status to user selections.

Auto test mode simulates automatic sequencing of inputs off -to-on and back to off in 1 millisecond intervals. Each status change is recorded as an event in the event log, along with events designating the start and end of test mode.

In **Manual test mode**, channels can be “forced” OFF or ON (overriding normal status). Click the desired check box(es) and then click the “Apply” button to simulate the selected states. Status registers (Modbus TCP) and test event records in the event log can be used to verify proper operation with application software. Finally, click the “End Test” button to return to normal operation. After 10 minutes of inactivity, the SER will revert automatically back to normal operation.

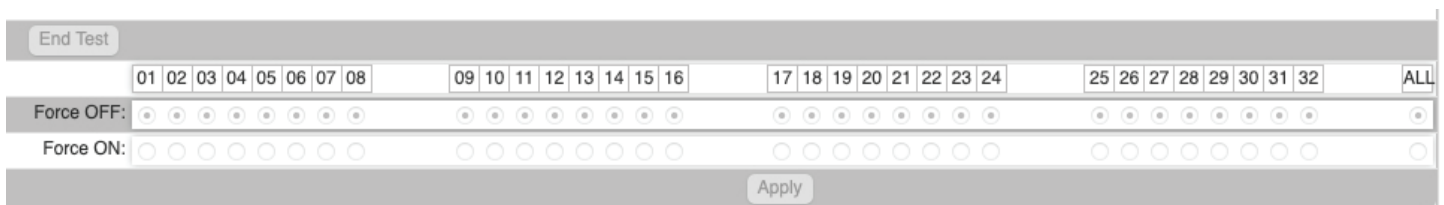

Figure 6-6. Control test web page—Manual test mode (close-up)

Diagnostics Page

Use the Diagnostics page to verify device data such as MAC address, serial number, hardware and firmware versions, available memory, time-sync values (including PTP attributes if applicable), available Modbus sockets, and self-diagnostics.

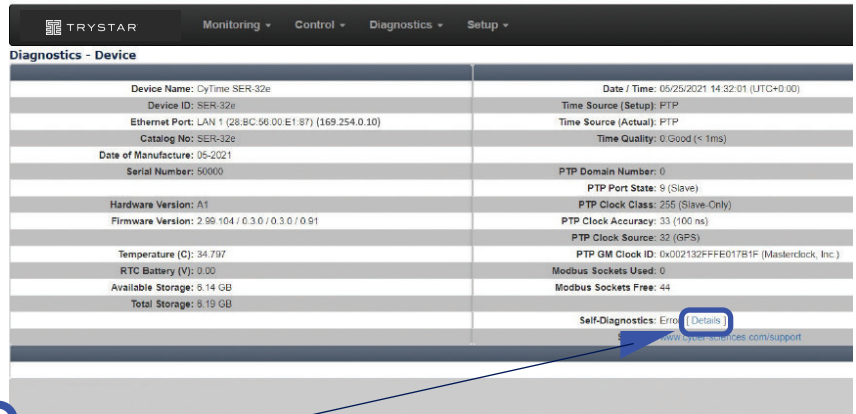

Figure 6-7. Diagnostics web page

Click the “Details” link to view an expanded list of diagnostics values, as shown



Figure 6-8. Self-diagnostics details

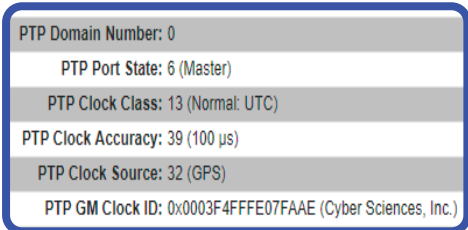

Figure 6-9. Typical PTP values (PTP master)

PTP Attributes—PTP Master

Shown at left are typical PTP diagnostics values under normal operating conditions for an SER configured as a PTP master.

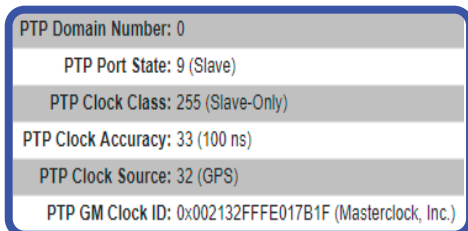

Figure 6-10. Typical PTP values (PTP slave)

PTP Attributes—PTP Slave

Shown at left are typical PTP diagnostics values under normal operating conditions for an SER configured as a PTP slave.

Power Control / Ride-through Module:

The SER-32e includes a Power Control module providing over 10 seconds of control power ride-through. The Power Control module is located in option slot 3 which is dedicated to this module.

Diagnostic status information is provided for the Power Control module through LED status indicators as well as the Diagnostics menus on the SER's display and web interface. No maintenance is required for this module during the service life of the SER under typical installation conditions.

Real-time Clock Battery Status

The SER-32e is equipped with a real-time clock (RTC) with battery backup to maintain relative time in the event of a power loss. The backup battery is expected to remain viable for the life of the SER, but may need to be replaced under some service conditions. Status of the RTC backup battery can be observed through the LED status indicators on the Power Control module as well as the Diagnostics menus on the SER's front panel display and web interface.

 **DANGER** 

HAZARD OF ELECTRIC SHOCK, EXPLOSION, OR ARC FLASH

- Only qualified workers should install this equipment.
- Before performing visual inspections, tests, or maintenance on this equipment, disconnect all sources of electric power. Assume that all circuits are live until they have been completely de-energized, tested, and tagged. Pay particular attention to the design of the power system. Consider all sources of power, including the possibility of backfeeding.
- Apply appropriate personal protective equipment (PPE) and follow safe electrical practices. For example, in the USA, see NFPA 70E.
- Turn off all power supplying the equipment in which the device is to be installed before installing and wiring the device.
- Always use a properly rated voltage sensing device to confirm that power is off.
- The successful operation of this equipment depends upon proper handling, installation, and operation. Neglecting fundamental installation requirements may lead to personal injury as well as damage to electrical equipment or other property.

Failure to follow these instructions can result in death or serious injury.

In the event the real-time clock battery requires replacement, follow these steps:

1. Remove control power from the SER.
2. Monitor the LED indicators on the Power Control module until they are all OFF.
3. Remove the Power Control module by pressing the two latches on the top and bottom of the module and pull out.
4. Remove the module front cover by gently lifting the clips to release the printed circuit board.
5. Remove the coin cell battery from the battery holder and replace it with an industrially rated CR2032 or BR2032 battery from Panasonic.
6. Re-attach the module's front panel by pressing it onto the board until the latches click into place.
7. Insert the module into slot 3 using the card guides until the latches engage with a click.
8. Reapply control power to the SER and confirm the status of the clock battery is good.

PRODUCT SPECIFICATIONS

Electrical		
Digital inputs	Number of inputs	32
	Voltage, operating	24 Vdc (-15% to +10%)
	Input impedance / current draw (max.)	10K ohms resistive / 1 mA
	Must turn on/off voltage	turn on: 20 Vdc / turn off: 9 Vdc
	Turn on time / turn off time (max.)	0.5 ms
	Isolation	Each input is optically isolated
High-speed Trigger Output	Relay type	Form A relay
	Maximum current	100 mA at 24 Vdc nominal
	Contact closure characteristics	Momentary contact closure, duration of 100 ms
Control Power	Voltage, operating	24 Vdc ($\pm 10\%$)
	Burden, steady state (max.)	7 VA
	Burden, momentary (max.)	Inrush current: 0.8 A for 5-8 ms
	Ride-through	> 10 seconds
Front Panel Display	4.3" TFT color touchscreen, adjustable brightness, screen saver	
Time Synchronization		
Time Source (IN) Protocols Supported	PTP slave	IEEE 1588-2019 (v2.1), E2E Default Profile, per Annex I.
	IRIG-B (via optional EZC-IRIG-B connector)	Unmodulated IRIG-B (5V DCLS) types B004, B007 (with year)
	DCF77 (via optional EZC-DCF77)	DCF77 (24 Vdc)
	SER inter-device time sync (legacy)	RS-485 (IRIG-B or DCF77 time code)
	NTP (SNTP) client	User-configurable NTP primary/secondary servers and update interval
Time-sync Output Protocols Supported	PTP master	IEEE 1588-2019 (v2.1), E2E Default Profile, per Annex I.
	IRIG-B (via optional PLX-5V connector)	Unmodulated IRIG-B (5V DCLS) type B007
Clock	IRIG-B (via optional PLX-24V)	IRIG-B (24V DCLS) type B007, compatible with STR-IDM
	DCF77 or 1per10 (via optional PLX-24V)	DCF77 (24 Vdc) or 1 pulse per 10 seconds (24 Vdc)
		RS-485
Clock Battery	Battery life (expected)	10 Years
	Replacement battery	Panasonic CR2032 or BR2032

Communications	
Ethernet ports Ethernet protocols (10/100 Mbps)	2x, 10/100Base-TX, RJ45 connector, CAT5/5e/6/6a shielded cable Modbus TCP, PTP, NTP, HTTPS, RESTful API
Serial port (time-sync IN/OUT)	RS-485 (2-wire plus shield)
Secure web server (for setup and monitoring)	HTTPS, TLS v1.2/v1.3, 256 bit encryption
Simultaneous TCP connections	44 simultaneous Modbus connections
Mechanical	
Mounting	Standard DIN rail (EN 50022, 35 mm x 15 mm)
Wire sizes supported	#24 to #12 AWG (#26 to #14 AWG for 3-position EZC connectors)
Dimensions (W x H x D)	11.5 x 5.0 x 2.62 inches (292 x 127 x 66.5 mm)
Dimensions (W x H x D), in carton	12.5 x 6.5 x 4.5 inches (318 x 165 x 114 mm)
Weight (product alone / in carton)	2.4 lbs. (1.1 kg) / 3.5 lbs. (1.6 kg)
Environmental	
Operating temperature	-25 to +70 C
Storage temperature	-40 to +85 C
Humidity rating	5% to 95% relative humidity (non-condensing) at 40 C
Altitude rating	0 to 3000 meters (10,000 feet)
Sustainability	RoHS-compliant, lead-free
Regulatory	
Safety, USA	UL Listed (NRAQ-cULus, UL 61010-1, UL 61010-2-201)
Safety, Canada	CAN/CSA-C22.2 (61010-1-12, 61010-2-201)
Safety, Europe	CE mark (EN 61010-1:2010, EN 61010-2-201:2017)
Emissions / Immunity	EN 61326-1 (IEC 61326-1 : 2012)
Radiated emissions	CISPR 11, Class A, Group 1 (EN 55011) / FCC Part 15B, Class A
Electrostatic discharge	EN 61000-4-2
Radiated immunity	EN 61000-4-3
Electrical fast transient / burst immunity	EN 61000-4-4
Surge immunity	EN 61000-4-5
Conducted radio frequency immunity	EN 61000-4-6
W3C web standards	W3C-validated (standards-compliant for browser-independence)

1. The Unmodulated IRIG-B signal must include the year (B004, B007), also known as enabling “IEEE-1344 extensions.” For more information on IRIG-B, please refer to Trystar [Tech Note TN-102](#), “Overview of IRIG-B Time Codes.”

INCLUDED SOFTWARE LICENSES

This Trystar product is provided with software which is proprietary to Trystar, Inc. and is licensed under the terms of the End User License Agreement available at: https://www.trystar.com/wp-content/uploads/2022/01/CSI_Software_License.pdf.

This Trystar product is also provided with certain open source software components (collectively, "OSS") developed by third parties. Each OSS component provided is listed below along with license and copyright information. By using the software provided with this product, you are agreeing to the terms of the applicable licenses. If you do not agree to those terms, you should not use the software. Where the applicable licenses require specific terms or notices to be included with distributions of the covered open source components, those terms are also listed below. However, you should not rely only on those terms, and should access the relevant licenses at the indicated locations for the complete terms and conditions that apply to each software component.

EMAC OE Gnu/Linux

Version: 5.8

License: MIT

Copyright: EMAC inc(c) 2022 EMAC OE GNU/Linux

Link: <http://git.emacinc.com/OE/emacs-oe/-/blob/master/LICENSE>

Permission is hereby granted, free of charge, to any person obtaining a copy of this software and associated documentation files (the "Software"), to deal in the Software without restriction, including without limitation the rights to use, copy, modify, merge, publish, distribute, sublicense, and/or sell copies of the Software, and to permit persons to whom the Software is furnished to do so, subject to the following conditions:

The above copyright notice and this permission notice shall be included in all copies or substantial portions of the Software.

Notice: THE SOFTWARE IS PROVIDED "AS IS", WITHOUT WARRANTY OF ANY KIND, EXPRESS OR IMPLIED, INCLUDING BUT NOT LIMITED TO THE WARRANTIES OF MERCHANTABILITY, FITNESS FOR A PARTICULAR PURPOSE AND NONINFRINGEMENT. IN NO EVENT SHALL THE AUTHORS OR COPYRIGHT HOLDERS BE LIABLE FOR ANY CLAIM, DAMAGES OR OTHER LIABILITY, WHETHER IN AN ACTION OF CONTRACT, TORT OR OTHERWISE, ARISING FROM, OUT OF OR IN CONNECTION WITH THE SOFTWARE OR THE USE OR OTHER DEALINGS IN THE SOFTWARE.

TinyXML

Version: 2.6.2

License: Zlib

Copyright: n/a

Link: <https://github.com/csi12345/tinyxml2/blob/master/LICENSE.txt>**JAM STAPL**

Version: 2.5

License: Altera

Copyright: Altera Corporation, 101 Innovation Drive, San Jose, CA 95134 and its licensors - Restricted Rights

Link: <https://www.intel.com/content/www/us/en/programmable/support/support-resources/download/licensing/lic-jam.html>**ArduinoJSON**

Version: 6.11.3

License: MIT

Copyright: Copyright © 2014-2021 Benoit BLANCHON

Link: <https://github.com/bblanchon/ArduinoJson/blob/6.x/LICENSE.md>

Notice: Permission is hereby granted, free of charge, to any person obtaining a copy of this software and associated documentation files (the “Software”), to deal in the Software without restriction, including without limitation the rights to use, copy, modify, merge, publish, distribute, sublicense, and/or sell copies of the Software, and to permit persons to whom the Software is furnished to do so, subject to the following conditions:

The above copyright notice and this permission notice shall be included in all copies or substantial portions of the Software.

LinuxPTP

Version: 3.1.1

License: GPL v2.0

Copyright: Copyright (C) 1989, 1991 Free Software Foundation, Inc., 51 Franklin Street, Fifth Floor, Boston, MA 02110-1301 USA

Link: <https://github.com/richardcochran/linuxptp/blob/master/COPYING>

Notice: Everyone is permitted to copy and distribute verbatim copies of this license document, but changing it is not allowed.

Bootstrap

Version: 3.3.7

License: MIT

Copyright: Copyright © 2011-2021 Twitter, Inc. / Copyright © 2011-2021 The Bootstrap Authors

Link: <https://github.com/twbs/bootstrap/blob/main/LICENSE>

Notice:

Permission is hereby granted, free of charge, to any person obtaining a copy of this software and associated documentation files (the “Software”), to deal in the Software without restriction, including without limitation the rights to use, copy, modify, merge, publish, distribute, sublicense, and/or sell copies of the Software, and to permit persons to whom the Software is furnished to do so, subject to the following conditions:

The above copyright notice and this permission notice shall be included in all copies or substantial portions of the Software.

Chrony

Version: 4.2

License: GPL v2.0

Copyright: Copyright © 1989, 1991 Free Software Foundation Inc., 51 Franklin Street, Fifth Floor, Boston, MA 02110-1301 USA

Link: <https://gitlab.com/chrony/chrony/-/blob/4.2/COPYING>

Notice:

Everyone is permitted to copy and distribute verbatim copies of this license document, but changing it is not allowed.

JQuery

Version: 1.12.4

License: MIT

Copyright: Copyright © Open JS Foundation and other contributors, <https://openjsf.org/>

Link: <https://jquery.org/license/>

Notice:

Permission is hereby granted, free of charge, to any person obtaining a copy of this software and associated documentation files (the “Software”), to deal in the Software without restriction, including without limitation the rights to use, copy, modify, merge, publish,

distribute, sublicense, and/or sell copies of the Software, and to permit persons to whom the Software is furnished to do so, subject to the following conditions:

The above copyright notice and this permission notice shall be included in all copies or substantial portions of the Software.

JQuery UI

Version: 1.12.1

License: MIT

Copyright: Copyright © Open JS Foundation and other contributors,
<https://jquery.org/>

Link: <https://github.com/jquery/jquery-ui/blob/main/LICENSE.txt>

Notice: Permission is hereby granted, free of charge, to any person obtaining a copy of this software and associated documentation files (the “Software”), to deal in the Software without restriction, including without limitation the rights to use, copy, modify, merge, publish, distribute, sublicense, and/or sell copies of the Software, and to permit persons to whom the Software is furnished to do so, subject to the following conditions:

The above copyright notice and this permission notice shall be included in all copies or substantial portions of the Software

Moment.js

Version: 2.29.2

License: MIT

Copyright: Copyright © JS Foundation and other contributors,
<https://openjsf.org/>

Link: <https://github.com/moment/moment>

Notice: Permission is hereby granted, free of charge, to any person obtaining a copy of this software and associated documentation files (the “Software”), to deal in the Software without restriction, including without limitation the rights to use, copy, modify, merge, publish, distribute, sublicense, and/or sell copies of the Software, and to permit persons to whom the Software is furnished to do so, subject to the following conditions:

The above copyright notice and this permission notice shall be included in all copies or substantial portions of the Software.

Tablesorter

Version: 9-Jun-14

License: MIT

Copyright: Copyright © 2014 Christian Bach

Link: <https://github.com/christianbach/tablesorter>

Notice: Permission is hereby granted, free of charge, to any person obtaining a copy of this software and associated documentation files (the “Software”), to deal in the Software without restriction, including without limitation the rights to use, copy, modify, merge, publish, distribute, sublicense, and/or sell copies of the Software, and to permit persons to whom the Software is furnished to do so, subject to the following conditions:

The above copyright notice and this permission notice shall be included in all copies or substantial portions of the Software.

GNU LIBRARY GENERAL PUBLIC LICENSE

Version 2, June 1991

Copyright (C) 1991 Free Software Foundation, Inc. 51 Franklin St, Fifth Floor, Boston, MA 02110-1301, USA

Everyone is permitted to copy and distribute verbatim copies of this license document, but changing it is not allowed.

[This is the first released version of the library GPL. It is numbered 2 because it goes with version 2 of the ordinary GPL.]

Preamble

The licenses for most software are designed to take away your freedom to share and change it. By contrast, the GNU General Public Licenses are intended to guarantee your freedom to share and change free software—to make sure the software is free for all its users.

This license, the Library General Public License, applies to some specially designated Free Software Foundation software, and to any other libraries whose authors decide to use it. You can use it for your libraries, too.

When we speak of free software, we are referring to freedom, not price. Our General Public Licenses are designed to make sure that you have the freedom to distribute copies of free software (and charge for this service if you wish), that you receive source code or can get it if you want it, that you can change the software or use pieces of it in new free programs; and that you know you can do these things.

To protect your rights, we need to make restrictions that forbid anyone to deny you these rights or to ask you to surrender the rights. These restrictions translate to certain responsibilities for you if you distribute copies of the library, or if you modify it.

For example, if you distribute copies of the library, whether gratis or for a fee, you must give the recipients all the rights that we gave you. You must make sure that they, too, receive or can get the source code. If you link a program with the library, you must provide complete object files to the recipients so that they can relink them with the library, after making changes to the library and recompiling it. And you must show them these terms so they know their rights.

Our method of protecting your rights has two steps: (1) copyright the library, and (2) offer you this license which gives you legal permission to copy, distribute and/ or modify the library.

Also, for each distributor's protection, we want to make certain that everyone understands that there is no warranty for this free library. If the library is modified by someone else and passed on, we want its recipients to know that what they have is not the original version, so that any problems introduced by others will not reflect on the original authors' reputations.

Finally, any free program is threatened constantly by software patents. We wish to avoid the danger that companies distributing free software will individually obtain patent licenses, thus in effect transforming the program into proprietary software. To prevent this, we have made it clear that any patent must be licensed for everyone's free use or not licensed at all.

Most GNU software, including some libraries, is covered by the ordinary GNU General Public License, which was designed for utility programs. This license, the GNU Library General Public License, applies to certain designated libraries. This license is quite different from the ordinary one; be sure to read it in full, and don't assume that anything in it is the same as in the ordinary license.

The reason we have a separate public license for some libraries is that they blur the distinction we usually make between modifying or adding to a program and simply using it. Linking a program with a library, without changing the library, is in some sense simply using the library, and is analogous to running a utility program or application program. However, in a textual and legal sense, the linked executable is a combined work, a derivative of the original library, and the ordinary General Public License treats it as such.

Because of this blurred distinction, using the ordinary General Public License for libraries did not effectively promote software sharing, because most developers did not use the libraries. We concluded that weaker conditions might promote sharing better.

However, unrestricted linking of non-free programs would deprive the users of those programs of all benefit from the free status of the libraries themselves. This Library General Public License is intended to permit developers of non-free programs to use free libraries, while preserving your freedom as a user of such programs to change the free libraries that are incorporated in them. (We have not seen how to achieve this as regards changes in header files, but we have achieved it as regards changes in the actual functions of the Library.) The hope is that this will lead to faster development of free libraries.

The precise terms and conditions for copying, distribution and modification follow. Pay close attention to the difference between a "work based on the library" and a "work that uses the library". The former contains code derived from the library, while the latter only works together with the library.

Note that it is possible for a library to be covered by the ordinary General Public License rather than by this special one.

TERMS AND CONDITIONS FOR COPYING, DISTRIBUTION AND MODIFICATION

0. This License Agreement applies to any software library which contains a notice placed by the copyright holder or other authorized party saying it may be distributed under the terms of this Library General Public License (also called "this License"). Each licensee is addressed as "you".

A "library" means a collection of software functions and/or data prepared so as to be conveniently linked with application programs (which use some of those functions and data) to form executables.

The "Library", below, refers to any such software library or work which has been distributed under these terms. A "work based on the Library" means either the Library or any derivative work under copyright law: that is to say, a work containing the Library or a portion of it, either verbatim or with modifications and/or translated straightforwardly into another language. (Hereinafter, translation is included without limitation in the

term “modification”.)

“Source code” for a work means the preferred form of the work for making modifications to it. For a library, complete source code means all the source code for all modules it contains, plus any associated interface definition files, plus the scripts used to control compilation and installation of the library.

Activities other than copying, distribution and modification are not covered by this License; they are outside its scope. The act of running a program using the Library is not restricted, and output from such a program is covered only if its contents constitute a work based on the Library (independent of the use of the Library in a tool for writing it). Whether that is true depends on what the Library does and what the program that uses the Library does.

1. You may copy and distribute verbatim copies of the Library’s complete source code as you receive it, in any medium, provided that you conspicuously and appropriately publish on each copy an appropriate copyright notice and disclaimer of warranty; keep intact all the notices that refer to this License and to the absence of any warranty; and distribute a copy of this License along with the Library.

You may charge a fee for the physical act of transferring a copy, and you may at your option offer warranty protection in exchange for a fee.

2. You may modify your copy or copies of the Library or any portion of it, thus forming a work based on the Library, and copy and distribute such modifications or work under the terms of Section 1 above, provided that you also meet all of these conditions:

- a. The modified work must itself be a software library.
- b. You must cause the files modified to carry prominent notices stating that you changed the files and the date of any change.
- c. You must cause the whole of the work to be licensed at no charge to all third parties under the terms of this License.
- d. If a facility in the modified Library refers to a function or a table of data to be supplied by an application program that uses the facility, other than as an argument passed when the facility is invoked, then you must make a good faith effort to ensure that, in the event an application does not supply such function or table, the facility still operates, and performs whatever part of its purpose remains meaningful.

(For example, a function in a library to compute square roots has a purpose that is entirely well-defined independent of the application. Therefore, Subsection 2d requires that any application-supplied function or table used by this function must be optional: if the application does not supply it, the square root function must still compute square roots.)

These requirements apply to the modified work as a whole. If identifiable sections of that work are not derived from the Library, and can be reasonably considered independent and separate works in themselves, then this License, and its terms, do not apply to those sections when you distribute them as separate works. But when you distribute the same sections as

part of a whole which is a work based on the Library, the distribution of the whole must be on the terms of this License, whose permissions for other licensees extend to the entire whole, and thus to each and every part regardless of who wrote it.

Thus, it is not the intent of this section to claim rights or contest your rights to work written entirely by you; rather, the intent is to exercise the right to control the distribution of derivative or collective works based on the Library.

In addition, mere aggregation of another work not based on the Library with the Library (or with a work based on the Library) on a volume of a storage or distribution medium does not bring the other work under the scope of this License.

3. You may opt to apply the terms of the ordinary GNU General Public License instead of this License to a given copy of the Library. To do this, you must alter all the notices that refer to this License, so that they refer to the ordinary GNU General Public License, version 2, instead of to this License. (If a newer version than version 2 of the ordinary GNU General Public License has appeared, then you can specify that version instead if you wish.) Do not make any other change in these notices.

Once this change is made in a given copy, it is irreversible for that copy, so the ordinary GNU General Public License applies to all subsequent copies and derivative works made from that copy.

This option is useful when you wish to copy part of the code of the Library into a program that is not a library.

4. You may copy and distribute the Library (or a portion or derivative of it, under Section 2) in object code or executable form under the terms of Sections 1 and 2 above provided that you accompany it with the complete corresponding machine-readable source code, which must be distributed under the terms of Sections 1 and 2 above on a medium customarily used for software interchange.

If distribution of object code is made by offering access to copy from a designated place, then offering equivalent access to copy the source code from the same place satisfies the requirement to distribute the source code, even though third parties are not compelled to copy the source along with the object code.

5. A program that contains no derivative of any portion of the Library, but is designed to work with the Library by being compiled or linked with it, is called a “work that uses the Library”. Such a work, in isolation, is not a derivative work of the Library, and therefore falls outside the scope of this License.

However, linking a “work that uses the Library” with the Library creates an executable that is a derivative of the Library (because it contains portions of the Library), rather than a “work that uses the library”. The executable is therefore covered by this License. Section 6 states terms for distribution of such executables.

When a “work that uses the Library” uses material from a header file that is part of the Library, the object code for the work may be a derivative work of the Library even though the source code is not. Whether this is true is especially significant if the work can be linked without the Library,

or if the work is itself a library. The threshold for this to be true is not precisely defined by law.

If such an object file uses only numerical parameters, data structure layouts and accessors, and small macros and small inline functions (ten lines or less in length), then the use of the object file is unrestricted, regardless of whether it is legally a derivative work. (Executables containing this object code plus portions of the Library will still fall under Section 6.)

Otherwise, if the work is a derivative of the Library, you may distribute the object code for the work under the terms of Section 6. Any executables containing that work also fall under Section 6, whether or not they are linked directly with the Library itself.

6. As an exception to the Sections above, you may also compile or link a “work that uses the Library” with the Library to produce a work containing portions of the Library, and distribute that work under terms of your choice, provided that the terms permit modification of the work for the customer’s own use and reverse engineering for debugging such modifications.

You must give prominent notice with each copy of the work that the Library is used in it and that the Library and its use are covered by this License. You must supply a copy of this License. If the work during execution displays copyright notices, you must include the copyright notice for the Library among them, as well as a reference directing the user to the copy of this License. Also, you must do one of these things:

- a. Accompany the work with the complete corresponding machine-readable source code for the Library including whatever changes were used in the work (which must be distributed under Sections 1 and 2 above); and, if the work is an executable linked with the Library, with the complete machine-readable “work that uses the Library”, as object code and/or source code, so that the user can modify the Library and then relink to produce a modified executable containing the modified Library. (It is understood that the user who changes the contents of definitions files in the Library will not necessarily be able to recompile the application to use the modified definitions.)
- b. Accompany the work with a written offer, valid for at least three years, to give the same user the materials specified in Subsection 6a, above, for a charge no more than the cost of performing this distribution.
- c. If distribution of the work is made by offering access to copy from a designated place, offer equivalent access to copy the above specified materials from the same place.
- d. Verify that the user has already received a copy of these materials or that you have already sent this user a copy.

For an executable, the required form of the “work that uses the Library” must include any data and utility programs needed for reproducing the executable from it. However, as a special exception, the source code distributed need not include anything that is normally distributed (in either source or binary form) with the major components (compiler, kernel, and so on) of the operating system on which the executable runs, unless that component itself accompanies the executable.

It may happen that this requirement contradicts the license restrictions of other proprietary libraries that do not normally accompany the operating system. Such a contradiction means you cannot use both them and the Library together in an executable that you distribute.

7. You may place library facilities that are a work based on the Library side-by-side in a single library together with other library facilities not covered by this License, and distribute such a combined library, provided that the separate distribution of the work based on the Library and of the other library facilities is otherwise permitted, and provided that you do these two things:

- a. Accompany the combined library with a copy of the same work based on the Library, uncombined with any other library facilities. This must be distributed under the terms of the Sections above.
- b. Give prominent notice with the combined library of the fact that part of it is a work based on the Library, and explaining where to find the accompanying uncombined form of the same work.

8. You may not copy, modify, sublicense, link with, or distribute the Library except as expressly provided under this License. Any attempt otherwise to copy, modify, sublicense, link with, or distribute the Library is void, and will automatically terminate your rights under this License. However, parties who have received copies, or rights, from you under this License will not have their licenses terminated so long as such parties remain in full compliance.

9. You are not required to accept this License, since you have not signed it. However, nothing else grants you permission to modify or distribute the Library or its derivative works. These actions are prohibited by law if you do not accept this License. Therefore, by modifying or distributing the Library (or any work based on the Library), you indicate your acceptance of this License to do so, and all its terms and conditions for copying, distributing or modifying the Library or works based on it.

10. Each time you redistribute the Library (or any work based on the Library), the recipient automatically receives a license from the original licensor to copy, distribute, link with or modify the Library subject to these terms and conditions. You may not impose any further restrictions on the recipients' exercise of the rights granted herein. You are not responsible for enforcing compliance by third parties to this License.

11. If, as a consequence of a court judgment or allegation of patent infringement or for any other reason (not limited to patent issues), conditions are imposed on you (whether by court order, agreement or otherwise) that contradict the conditions of this License, they do not excuse you from the conditions of this License. If you cannot distribute so as to satisfy simultaneously your obligations under this License and any other pertinent obligations, then as a consequence you may not distribute the Library at all. For example, if a patent license would not permit royalty-free redistribution of the Library by all those who receive copies directly or indirectly through you, then the only way you could satisfy both it and this License would be to refrain entirely from distribution of the Library.

If any portion of this section is held invalid or unenforceable under any particular circumstance, the balance of the section is intended to apply, and the section as a whole is intended to apply in other circumstances.

It is not the purpose of this section to induce you to infringe any patents or other property right claims or to contest validity of any such claims; this section has the sole purpose of protecting the integrity of the free software distribution system which is implemented by public license practices. Many people have made generous contributions to the wide range of software distributed through that system in reliance on consistent application of that system; it is up to the author/donor to decide if he or she is willing to distribute software through any other system and a licensee cannot impose that choice.

This section is intended to make thoroughly clear what is believed to be a consequence of the rest of this License.

12. If the distribution and/or use of the Library is restricted in certain countries either by patents or by copyrighted interfaces, the original copyright holder who places the Library under this License may add an explicit geographical distribution limitation excluding those countries, so that distribution is permitted only in or among countries not thus excluded. In such case, this License incorporates the limitation as if written in the body of this License.

13. The Free Software Foundation may publish revised and/or new versions of the Library General Public License from time to time. Such new versions will be similar in spirit to the present version, but may differ in detail to address new problems or concerns.

Each version is given a distinguishing version number. If the Library specifies a version number of this License which applies to it and “any later version”, you have the option of following the terms and conditions either of that version or of any later version published by the Free Software Foundation. If the Library does not specify a license version number, you may choose any version ever published by the Free Software Foundation.

14. If you wish to incorporate parts of the Library into other free programs whose distribution conditions are incompatible with these, write to the author to ask for permission. For software which is copyrighted by the Free Software Foundation, write to the Free Software Foundation; we sometimes make exceptions for this. Our decision will be guided by the two goals of preserving the free status of all derivatives of our free software and of promoting the sharing and reuse of software generally.

NO WARRANTY

15. BECAUSE THE LIBRARY IS LICENSED FREE OF CHARGE, THERE IS NO WARRANTY FOR THE LIBRARY, TO THE EXTENT PERMITTED BY APPLICABLE LAW. EXCEPT WHEN OTHERWISE STATED IN WRITING THE COPYRIGHT HOLDERS AND/OR OTHER PARTIES PROVIDE THE LIBRARY “AS IS” WITHOUT WARRANTY OF ANY KIND, EITHER EXPRESSED OR IMPLIED, INCLUDING, BUT NOT LIMITED TO, THE IMPLIED WARRANTIES OF MERCHANTABILITY AND FITNESS FOR A PARTICULAR PURPOSE. THE ENTIRE RISK AS TO THE QUALITY AND PERFORMANCE OF THE LIBRARY IS WITH YOU. SHOULD THE LIBRARY PROVE DEFECTIVE, YOU ASSUME THE COST OF ALL NECESSARY SERVICING, REPAIR OR CORRECTION.

16. IN NO EVENT UNLESS REQUIRED BY APPLICABLE LAW OR AGREED TO IN WRITING WILL ANY COPYRIGHT HOLDER, OR ANY OTHER PARTY WHO MAY MODIFY AND/OR REDISTRIBUTE THE

LIBRARY AS PERMITTED ABOVE, BE LIABLE TO YOU FOR DAMAGES, INCLUDING ANY GENERAL, SPECIAL, INCIDENTAL OR CONSEQUENTIAL DAMAGES ARISING OUT OF THE USE OR INABILITY TO USE THE LIBRARY (INCLUDING BUT NOT LIMITED TO LOSS OF DATA OR DATA BEING RENDERED INACCURATE OR LOSSES SUSTAINED BY YOU OR THIRD PARTIES OR A FAILURE OF THE LIBRARY TO OPERATE WITH ANY OTHER SOFTWARE), EVEN IF SUCH HOLDER OR OTHER PARTY HAS BEEN ADVISED OF THE POSSIBILITY OF SUCH DAMAGES.

END OF TERMS AND CONDITIONS

